

TPM⁺ dynamic / high torque / power

Operating Manual

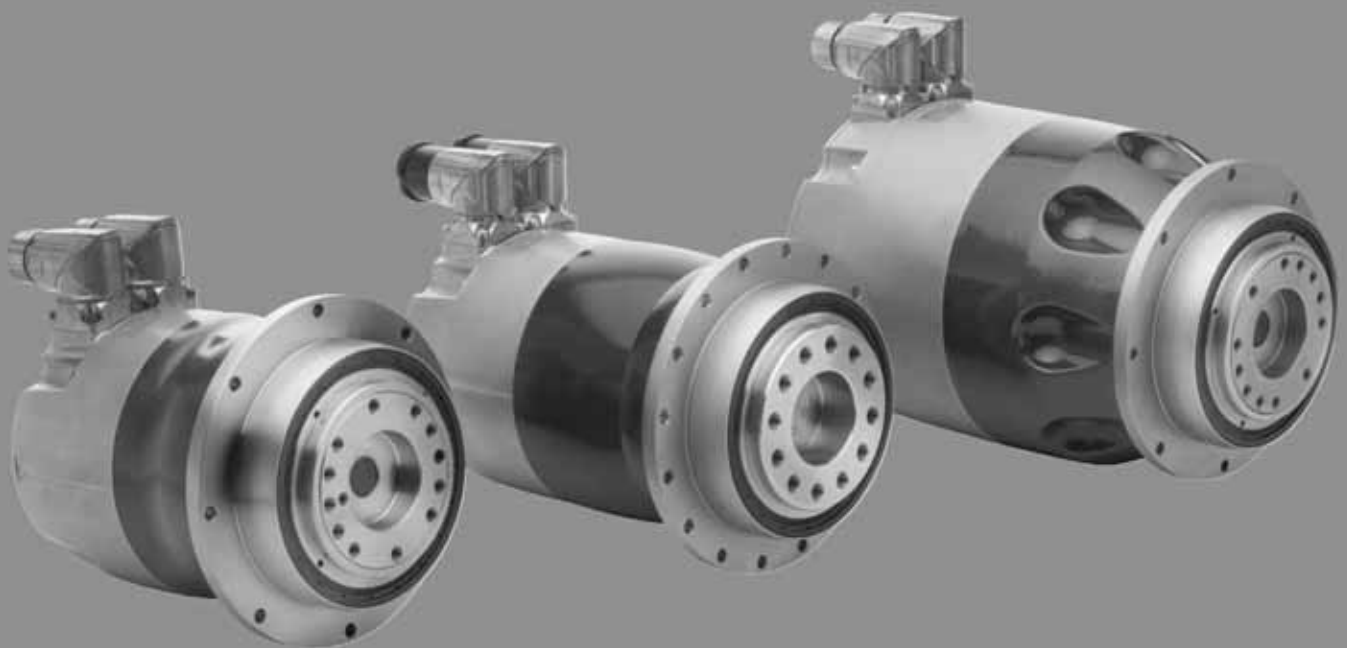

Revision history

Revision	Date	Comment	Chapter
01	16.12.09	New version	All
02	13.04.10	Technical data	9.4
03	25.07.11	high torque	All
04	03.02.17	W-alpha	All
05	27.02.17	Service-Tel	All
06	21.06.17	Speedtec counter plug	5.4
07	03.08.17	Security, Technical data	All

Service

In case you have technical questions,
please contact:

WITTENSTEIN alpha GmbH

Customer Service
Walter-Wittenstein-Straße 1
D-97999 Igersheim

Tel.: +49 7931 493-12900

Fax: +49 7931 493-10903

E-mail: service@wittenstein.de

© WITTENSTEIN alpha GmbH 2017

This documentation is copyright protected.

reserves all the rights to photo-mechanical reproduction, copying, and the distribution
by special processes (such as computers, file media, data networks), even in parts.

Subject to technical and content changes without notice

Contents

1	About this manual	5
1.1	Signal words	5
1.2	Safety symbols.....	5
1.3	Design of the safety instructions	6
1.4	Information symbols.....	6
2	Safety	7
2.1	EU Low Voltage Directive	7
2.2	Dangers	7
2.3	Personnel.....	7
2.4	Intended use	7
2.5	Reasonably foreseeable misuse.....	8
2.6	Guarantee and liability	8
2.7	General safety instructions	8
2.8	Safety signs	10
3	Description of the servo actuator	11
3.1	Identification plate	11
3.2	Ordering code	12
3.3	Performance statistics.....	12
3.4	Weight.....	12
3.4.1	Weight TPM ⁺ dynamic.....	12
3.4.2	Weight TPM ⁺ high torque	13
3.4.3	Weight TPM ⁺ power	13
4	Transport and storage	14
4.1	Scope of delivery	14
4.2	Packaging	14
4.3	Transport.....	14
4.4	Storage	14
5	Assembly	15
5.1	Preparations.....	15
5.2	Mounting the servo actuator onto a machine.....	15
5.3	Components mounted on the output side	16
5.4	Installing electrical connections	16
6	Startup and operation	18
6.1	Safety instructions and operating conditions	18
6.2	Data for the electrical startup	18
7	Maintenance and disposal	20
7.1	Maintenance work	20
7.1.1	Refreshment of holding brake	20
7.1.2	Visual inspection	21
7.1.3	Checking the tightening torques.....	21
7.1.4	Cleaning	22
7.2	Startup after maintenance work	22
7.3	Maintenance schedule	22
7.4	Information on the lubricant used.....	22
7.5	Disposal	23
8	Malfunctions	24

9 Appendix	26
9.1 Specifications on mounting onto a machine	26
9.1.1 Specifications for the TPM ⁺ dynamic/TPM ⁺ power version	26
9.1.2 Specifications for the TPM ⁺ high torque version	26
9.2 Specifications on mounting on the gear output side.....	26
9.2.1 Thread in output flange, TPM ⁺ dynamic	26
9.2.2 Thread in output flange, TPM ⁺ high torque	27
9.2.3 Thread in output flange, TPM ⁺ power.....	27
9.3 Tightening torques for common thread sizes in general mechanical engineering	27
9.4 Technical specifications	27
9.4.1 Moments of inertia TPM ⁺ dynamic	27
9.4.2 Moments of inertia TPM ⁺ high torque.....	28
9.4.3 Moments of inertia TPM ⁺ power	29
9.4.4 Motor data, TPM ⁺ dynamic 320V, i = 16 – 31.....	30
9.4.5 Motor data, TPM ⁺ dynamic 320V, i = 61 – 91.....	31
9.4.6 Motor data, TPM ⁺ high torque 320V.....	31
9.4.7 Motor data, TPM ⁺ power 320V	32
9.4.8 Motor data, TPM ⁺ dynamic 560V, i = 16 – 31.....	33
9.4.9 Motor data, TPM ⁺ dynamic 560V, i = 61 – 91.....	34
9.4.10 Motor data, TPM ⁺ high torque 560V	34
9.4.11 Motor data, TPM ⁺ power 560V, i = 4 – 35	35
9.4.12 Motor data, TPM ⁺ power 560V, i = 40 – 100	36
9.4.13 Technical specifications, Resolver.....	37
9.4.14 Technical specifications Stegmann Hiperface absolute encoder.....	38
9.4.15 Technical specifications Stegmann Hiperface absolute encoder, Rockwell option.....	38
9.4.16 Technical specifications Heidenhain EnDat absolute encoder	39
9.4.17 Technical specifications Heidenhain Incremental	39
9.4.18 Technical specifications TTL Encoder incremental.....	40
9.4.19 Technical specifications temperature sensors KTY and NTC.....	40
9.4.20 Technical specifications temperature sensor PTC.....	41
9.4.21 Technical specifications brake TPM ⁺ dynamic	41
9.4.22 Technical specifications brake TPM ⁺ high torque.....	42
9.4.23 Technical specifications brake TPM ⁺ power	42
9.4.24 Pin assignment 1	42
9.4.25 Pin assignment 4	46
9.4.26 Pin assignment 5 TPM ⁺ dynamic.....	48
9.4.27 Pin assignment 6	49
9.4.28 Cable setup / Cable cross-section	50

1 About this manual

These instructions contain information necessary for the safe operation of the TPM+ dynamic/ TPM+ high torque/ TPM+ power servo actuator, referred to as the servo actuator in the following. If this manual is supplied with an amendment (e.g. for special applications), then the information in the amendment is valid. Contradictory specifications in this manual thereby become obsolete.

In case of questions on the special applications, please contact **WITTENSTEIN alpha GmbH**.

The operator must ensure that these instructions are read through by all persons assigned to install, operate, or maintain the servo actuator, and that they fully comprehend them.

Store these instructions within reach of the servo actuator.

These **safety instructions** should be shared with colleagues working in the vicinity of the device to ensure individual safety.

The original instructions were prepared in German; all other language versions are translations of these instructions.

1.1 Signal words

The following signal words are used to indicate possible hazards, prohibitions, and important information:

	⚠ DANGER
	This signal word points out to an imminent danger that can cause serious injuries and even death.
	⚠ WARNING
	This signal word points out to a possible danger that can cause serious injuries and even death.
	⚠ CAUTION
	This signal word points out to a possible danger that can cause slight to serious injuries.
	NOTICE
	This signal word points out to a possible danger that can cause material damage.
	A note without signal word draws your attention to application tips or especially important information when handling the servo actuator.

1.2 Safety symbols

The following safety symbols are used to bring your attention to dangers, prohibitions, and important information:



General danger



Hot surface



Suspended loads



Danger of being pulled in



Electric voltage



Flammable



Harmful to the environment



Information



Component sensitive to electrostatic discharge

1.3 Design of the safety instructions

The safety instructions of these instructions are designed according to the following pattern:

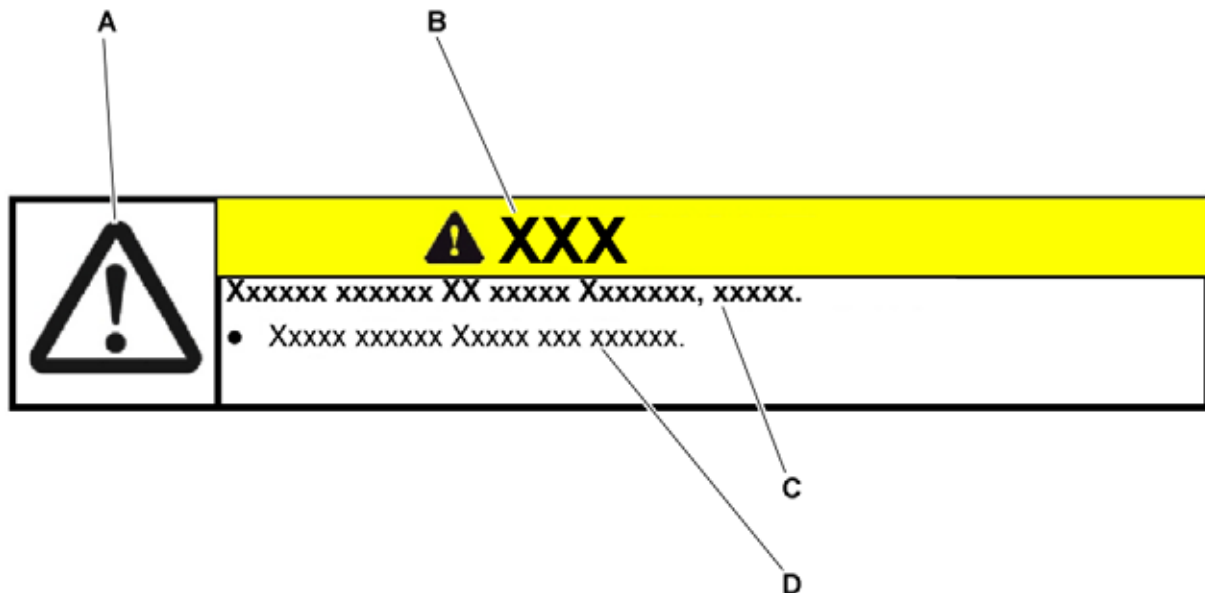

A = Safety symbol (see Chapter 1.2 "Safety symbols")

B = Signal word (see Chapter 1.1 "Signal words")

C = Type and consequence of the danger

D = Prevention of the danger

1.4 Information symbols

The following information symbols are used:

- Indicates an action to be performed
- ➡ Indicates the results of an action
- ① Provides additional information on handling

2 Safety

This operating manual, especially the safety instructions and the rules and regulations valid for the operating site, must be observed by all persons working with the servo actuator.

In addition to the safety instructions in this manual, also observe any (legal and otherwise) applicable environmental and accident prevention rules and regulations (e.g. personal safety equipment).

2.1 EU Low Voltage Directive

The servo actuator has been constructed in accordance with the directive 2014/35/EU. Observe applicable regulations for electrical installation (e.g. wire gauge, fuses).

It is the responsibility of the manufacturer of the plant to ensure all requirements for the entire system are fulfilled.

2.2 Dangers

The servo actuator has been constructed according to current technological standards and accepted safety regulations.

To avoid danger to the operator or damage to the machine, the servo actuator may be put to use only for its intended usage (see Chapter 2.4 "Intended use") and in a technically flawless and safe state.

- Read the general safety instructions before beginning work (see Chapter 2.7 "General safety instructions").

2.3 Personnel

Only technicians who have read and understood this operating manual may perform work on the servo actuator. Based on their training and experience, technicians must be able to evaluate the tasks assigned to them, in order to recognize and avoid risks.

2.4 Intended use

The servo actuator is designed to be installed in or connected to the following machines, incomplete machines or equipment:

- Stationary large-scale plant,
- Stationary industrial tools,
- Movable machines, not intended for road use and only provided for professional (industrial) use

In particular the following points must be observed:

- The servo actuator must be controlled by a servo controller.
- The servo actuator must not be used in applications with special environmental conditions e.g. vacuum, potentially explosive atmospheres, clean room or areas with radioactive contamination.
- Additional points must be observed for use in the food industry or the pharmaceutical industry:
 - The servo actuator may only be used next to or under the foodstuff/product area.
 - Observe also 7.4 "Information on the lubricant used".
- For risk-free operation, required safety devices have to be present, properly installed, and fully functional. They may not be removed, changed, bridged, or rendered ineffective.
- In case of an emergency shutdown, power failure and or damage to the electrical equipment, the servo actuator must be
 - switched off immediately,
 - secured against uncontrolled re-activation,
 - secured against uncontrolled after-running.
- The optionally installed brake is simply a holding brake and may only be utilized in emergency stop situations for braking the running servo actuator.

2.5 Reasonably foreseeable misuse

Any use that deviates from the approved technical data (e.g. speed, force, torque, temperature) is not use as intended and is therefore not permitted.

In particular the following applications are not permitted:



- Operation of the servo actuator, without properly installing it in or connecting it to other machines or other partly completed machines or equipment.
- Operation of the servo actuators in a defective state
- Operation of the servo actuator, without determining that the machine in which it is to be installed complies with the provisions of the Machinery Directive 2006/42/EC.
- Operation of the servo actuator in a potentially explosive environment
- Assembly of the servo actuator without prior acknowledgment of the operating / assembly manual
- Operation of the servo actuator without legible warning and information signs
- Use of improper lubricants
- Use of unsuitable servo controllers
- Use in improper installation, operating, performance and ambient conditions
- Assembly of the servo actuator by insufficiently competent personnel







2.6 Guarantee and liability

Guarantee and liability claims are excluded for personal injury and material damage in case of

- Ignoring the information on transport and storage
- Improper use (misuse)
- Improper or neglected maintenance and repair
- Improper assembly / disassembly or improper operation (e.g. test run without secure attachment)
- Operation of the servo actuator when safety devices and equipment are defective
- Operation of the servo actuator without lubricant
- Operation of a heavily soiled servo actuator
- Modifications or reconstructions that have been carried out without the approval of **WITTENSTEIN alpha GmbH**

2.7 General safety instructions

	<p style="text-align: center;">⚠ DANGER</p> <p>Faulty electrical connections or not approved, current-carrying components can cause serious injuries and even death.</p> <ul style="list-style-type: none"> ● Have all electrical connection work performed by qualified technicians only. ● Immediately replace damaged cables or plugs.
	<p style="text-align: center;">⚠ WARNING</p> <p>During generator operation, voltage is induced. This can lead to lethal current pulses.</p> <ul style="list-style-type: none"> ● Ensure that no plugs and connections are laying open during generator operation.

	<p style="text-align: center;">⚠ WARNING</p> <p>Objects flung out by rotating components can cause serious injuries.</p> <ul style="list-style-type: none"> • Remove objects and tools from the servo actuator before putting it into operation.
	<p style="text-align: center;">⚠ WARNING</p> <p>Rotating components on the servo actuator can pull in parts of the body and cause serious injuries and even death.</p> <ul style="list-style-type: none"> • Keep a sufficient distance to rotating machinery while the servo actuator is running. • Secure the machine against restarting and unintentional movements during assembly and maintenance work (e.g. uncontrolled lowering of lifting axes).
	<p style="text-align: center;">⚠ WARNING</p> <p>A damaged servo actuator can cause accidents with the risk of injury.</p> <ul style="list-style-type: none"> • Never operate a servo actuator that has been overloaded due to misuse or a machine crash (see Chapter 2.5 "Reasonably foreseeable misuse"). • Replace the affected servo actuators, even if no external damage is visible.
	<p style="text-align: center;">⚠ CAUTION</p> <p>Hot servo actuator housing (up to 125 °C) can cause serious burns.</p> <ul style="list-style-type: none"> • Touch the servo actuator housing only when wearing protective gloves or after the servo actuator has been idle for some time.
	<p style="text-align: center;">NOTICE</p> <p>Loose or overloaded screw connections can damage the servo actuator.</p> <ul style="list-style-type: none"> • Always use a calibrated torque wrench to tighten and check all screw connections for which a tightening torque has been specified.
	<p style="text-align: center;">⚠ WARNING</p> <p>Lubricants are flammable.</p> <ul style="list-style-type: none"> • Do not spray with water to extinguish. • Suitable extinguishing agents are powder, foam, water mist, and carbon dioxide. • Observe the safety instructions of the lubricant manufacturer (see Chapter 7.4 "Information on the lubricant used").
	<p style="text-align: center;">⚠ CAUTION</p> <p>Solvents and lubricants can cause skin irritations.</p> <ul style="list-style-type: none"> • Avoid direct skin contact.

**Solvents and lubricants can pollute soil and water.**

- Use and dispose of cleaning solvents and lubricants properly.

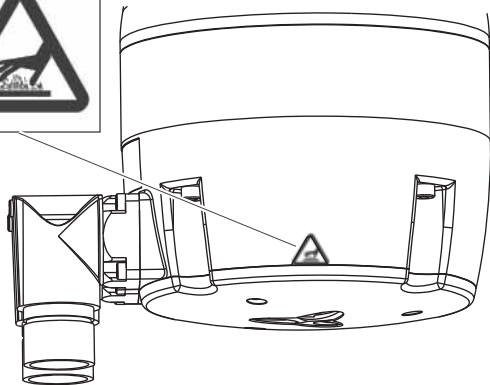
2.8 Safety signs

There is a safety sign on the servo actuator housing that warns against hot surfaces. This safety sign may **not** be removed.

3 Description of the servo actuator

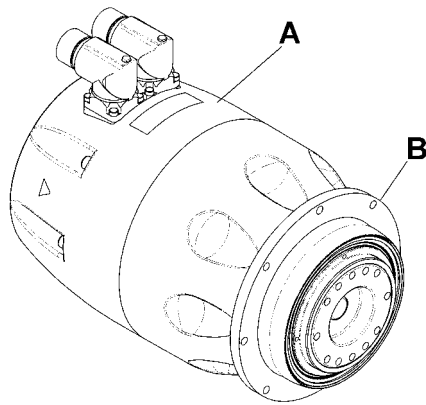

The servo actuator is a combination of a low-backlash planetary gearhead (B) and an AC servomotor (A).

The output bearing is designed to receive high external tilting moments.

There are two centering mechanisms for the output flange.

The AC servomotor is a brushless 3-phase synchronous motor with excitation by means of permanent magnets located on the rotor. A resolver or optical encoder takes care of the commutation or speed regulation. An optional permanent-magnet holding brake is integrated into the motor.

3.1 Identification plate

The identification plate is attached to the servo actuator housing.

C		G		D		A		E		F		B			
WITTENSTEIN alpha GmbH - Walter-Wittenstein-Str.1 - D97999 Igersheim															
Typ: TPMA050S-027R-6PO1-155D-W1-000										AC: 4xxx xxxx					
U _D [V]: 560		T ₂₀ [Nm]: 452		T _{2B} [Nm]: 950		T _{1max} [Nm]: 56,6		n _{1max} [rpm]: 5000		Class: F		Pos: xxx			
I ₀ [A _{rms}]: 17,9		I _{max} [A _{rms}]: 63,5		U _{brake} [V]: -		Ratio: 27,5		n _{2max} [rpm]: 164		Date: KW/JJ		IP: 65			
Lubrication: Oil Tribol 800/220						Pos: xxx		Serial No.: xxxxxx							
Drive: xxxxxxxx				Material No.: xxxxxxxx											
Back EMF		Inverter Duty		VPWM		Constant Torque (CT)									
K		Q		H		T		I		L		J			
S		M		N		R		P		O					
Designation						Designation									
A		Ordering code (see 3.2 "Ordering code")								K		Lubrication			
B		Article code								L		Mounting position			
C		Intermediate voltage								M		Max. speed			
D		Continuous stall torque at gear output								N		Max. speed of the motor			
E		Maximum acceleration torque at the gear output								O		Protection class			
F		Max. acceleration torque of the motor								P		Insulation class			
G		Continuous stall current of the motor								Q		Servo converter			
H		Max. acceleration current of the motor								R		Production date			
I		Brake voltage								S		Serial number			
J		Gearhead ratio								T		Material number (customer)			

Tbl-1: Identification plate

3.2 Ordering code

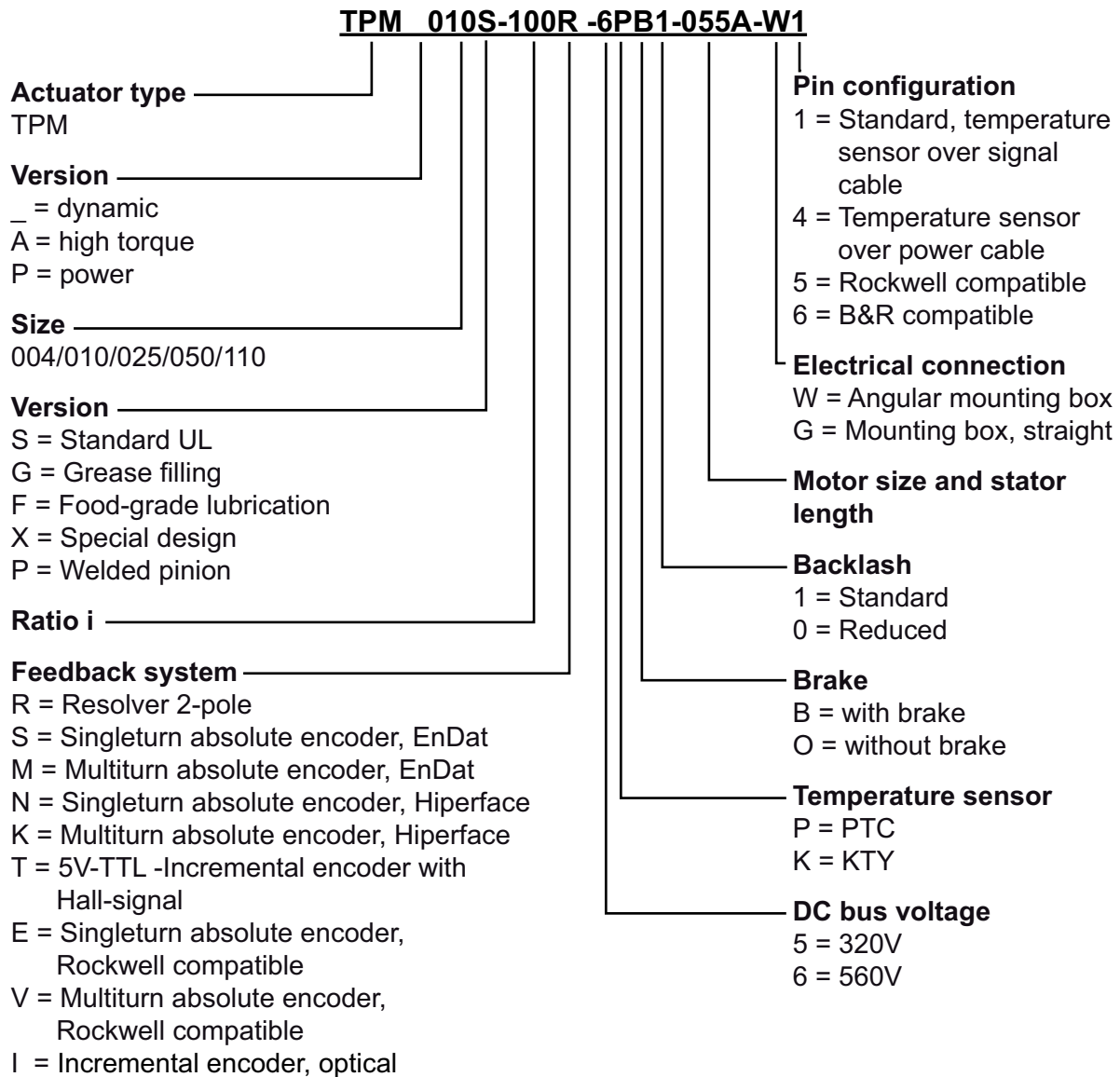

3.3 Performance statistics

Refer to Chapter 9.4 "Technical specifications" for the maximum permitted speeds and torques.

3.4 Weight

The standard weights of the servo actuators are specified in the tables "Tbl-2", "Tbl-3" and "Tbl-4" (with resolver, without brake). Depending on the design, the actual dimension can deviate by up to 20 %.

3.4.1 Weight TPM⁺ dynamic

Size TPM ⁺		004	010	025	050	110
Without brake [kg]	i = 16 –31	2.2	4.8	8.5	18.5	37.1
	i = 61 –91	2	4.3	7.1	14.7	35.9
With brake [kg]	i = 16 –31	3	5.3	9.8	23.7	39.6
	i = 61 –91	2.7	4.9	8.4	16.2	38.3

Tbl-2: Weight [kg]

3.4.2 Weight TPM⁺ high torque

Size TPM ⁺		010	025	050	110
Without brake [kg]	i = 22 –55	7.6	14.8	25.3	76.8
	i = 66	–	10.0	21.8	63.8
	i = 88	8.0	10.0	21.8	63.8
	i = 110	8.0	10.0	21.8	45.5
	i = 154, 220	6.5	10.0	21.8	45.5
With brake [kg]	i = 22 –55	8.1	15.9	27.5	80.0
	i = 66	–	10.5	22.9	67.0
	i = 88	8.5	10.5	22.9	67.0
	i = 110	8.5	10.5	22.9	46.8
	i = 154, 220	7.0	10.5	22.9	46.8

Tbl-3: Weight [kg]

3.4.3 Weight TPM⁺ power

Size TPM ⁺		004	010	025	050	110
Without brake [kg]	i = 4 –10	3.6	7.2	14.0	23.6	58.8
	i = 16 –35	3.7	7.4	14.5	25.1	59.6
	i = 40 –100	3.3	6.0	10.3	19.4	52.3
With brake [kg]	i = 4 –10	4	7.7	15	24.9	62.0
	i = 16 –35	4.1	7.9	15.5	26.4	62.8
	i = 40 –100	3.7	6.5	11.3	20.7	55.5

Tbl-4: Weight [kg]

4 Transport and storage

4.1 Scope of delivery



- Check the completeness of the delivery against the delivery note.
 - ① Missing parts or damage must be notified immediately in writing to the carrier, the insurance company, or **WITTENSTEIN alpha GmbH**.

4.2 Packaging

The servo actuator is delivered packed in foil and cardboard boxes.

- Entsorgen Sie die Verpackungsmaterialien an den dafür vorgesehenen Entsorgungsstellen. Observe the locally valid regulations for disposals.

4.3 Transport

	⚠ WARNING
	<p>Suspended loads can fall and can cause serious injuries and even death.</p> <ul style="list-style-type: none"> • Do not stand under suspended loads. • Secure the servo actuator with suitable fasteners (e.g. belts) before transport.
	NOTICE
	<p>Hard knocks, because of falling or hard dropping, can damage the servo actuator.</p> <ul style="list-style-type: none"> • Only use hoisting equipment and transports with sufficient capacity. • The maximum permitted lift capacity of a hoist may not be exceeded. • Lower the servo actuator slowly.

Specifications on the weights, refer to Chapter 3.4 "Weight".

Ambient temperatures between -20° C and +50° C are permissible for transport only.

4.4 Storage

Store the servo actuator in horizontal position and dry surroundings at a temperature of 0°C to +30°C in the original packaging. Store the servo actuator for a maximum of 2 years.

For storage logistics, we recommend the "first in –first out" method.

5 Assembly

- Read the general safety instructions before beginning work (see Chapter 2.7 "General safety instructions").

5.1 Preparations

	NOTICE
	<p>Many electronic components are sensitive against electrostatic discharge (ESD). This concerns in particular integrated circuits (IC), semiconductors, resistors with a tolerance of less than one percent as well as transistors and other components such as encoders.</p> <ul style="list-style-type: none"> • Observe the directives concerning ESD protection.

	NOTICE
	<p>Pressurized air can damage the servo actuator seals.</p> <ul style="list-style-type: none"> • Do not use pressurized air to clean the servo actuator.

- Clean/de-grease the output shaft /output flange of the servo actuator with a clean, lint-free cloth moistened with a suitable grease-dissolving but non-aggressive cleaning agent.
- Dry all fitting surfaces to neighboring components in order to achieve the proper friction values of the screw connections.
- Check the fitting surfaces additionally for damage and impurities.

5.2 Mounting the servo actuator onto a machine

	<p>The servo actuator is compliant for every mounting position; the lubricant quantity, however, is dependent on the mounting position. The mounting position and the lubricant that has been filled in is indicated on the identification plate (see Chapter 3.1 "Identification plate").</p> <ul style="list-style-type: none"> • Mount the servo actuator only in the specified mounting position.
	<ul style="list-style-type: none"> • Observe the safety and processing instructions for the threadlocker to be used.

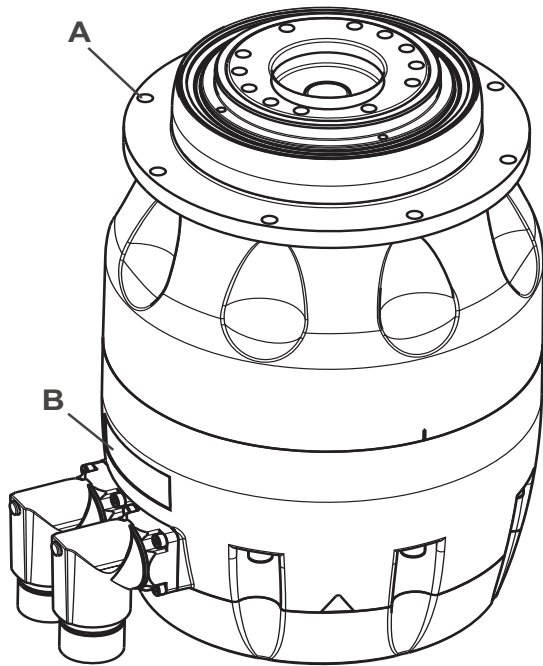





- Coat the fastening screws with a threadlocker (e.g. Loctite[®] 243).
- Fasten the servo actuator to the machine with the fastening screws through the through-holes (A).
 - ① Mount the servo actuator in such a way that the type plate (B) remains legible.
 - ① Do not use washers (e.g. plain washers, tooth lock washers).
 - ① For specified screw sizes and tightening torques, see Chapter 9.1 "Specifications on mounting onto a machine", Tables "Tbl-11" and "Tbl-12".

5.3 Components mounted on the output side

	NOTICE
<p>Distortions during assembly can damage the servo actuator.</p> <ul style="list-style-type: none"> ● Mount gearwheels and toothed belt pulleys onto the output flange without forcing. ● Never attempt to assemble by force or hammering! ● Only use suitable tools and devices for assembly. 	

- ① The prescribed screw sizes and tightening torques for the output flange can be found in Chapter 9.2 "Specifications on mounting on the gear output side", Tables "Tbl-13", "Tbl-14" and "Tbl-15".

5.4 Installing electrical connections

	<p style="text-align: center;">⚠ DANGER</p> <p>Electrically live components may result in electric shocks if touched and can cause serious injuries and even death.</p> <ul style="list-style-type: none"> ● Observe the five safety rules of electrical engineering before starting electrical installation work: <ul style="list-style-type: none"> - Disconnect. - Secure against being switched on again. - Check that there is no voltage. - Ground and short-circuit. - Cover neighboring and electrified parts. ● Check that protective caps are on the plugs. If protective caps are missing, check the plugs for damage and soiling.
	<p style="text-align: center;">⚠ DANGER</p> <p>Electric operation in moist areas may result in electric shocks and can cause serious injuries and even death.</p> <ul style="list-style-type: none"> ● Carry out the electrical assembly only in dry areas.
	<p style="text-align: center;">⚠ WARNING</p> <p>During generator operation, voltage is induced. This can lead to lethal current pulses.</p> <ul style="list-style-type: none"> ● Ensure that no plugs and connections are exposed during generator operation.
	<p>The cables of all servo actuators need to be laid out in such a way that a minimum bending radius of 10 x diameter is kept. Torsional load of the cables should be avoided.</p>

- ① speedtec-ready connectors are used in actuators of the respective series. These are speedtec connectors with an additional vibration O-ring.
- When using M23 screw counter plugs, the O-ring remains in place to protect against loosening due to vibration on the mounting socket.
 - When using **Speedtec counter plugs** the O-ring must be **removed**.
 - The maximum line length without disconnection points is 50 m. Observe also the maximum permissible line lengths of the servo converter being used.

6 Startup and operation

6.1 Safety instructions and operating conditions

- Read the general safety instructions before beginning work (see Chapter 2.7 "General safety instructions").
- ① Wearing hearing protection in the vicinity of the servo actuator is recommended.

	<p>Improper use can cause damage to the servo actuator.</p> <ul style="list-style-type: none"> ● Ensure that <ul style="list-style-type: none"> - The ambient temperature does not drop below 0 °C or exceed +40 °C, - The surface temperature on the gearhead does not exceed +90°C, - The surface temperature on the engine does not exceed +115°C, - The installation altitude is not above 1000 m NHN. ● For other conditions of use, consult our Customer Service department. ● Use the sensor only up to its maximum limit values, see Chapter 9.4 "Technical specifications". ● Only use the servo actuator in a clean, dust-free and dry environment. ● Operate the servo actuator only in the mounting position that is specified on the identification plate.
--	--

6.2 Data for the electrical startup

The specified data is intended for the electrical startup.

	NOTICE
	<p>The servo controllers of the different manufacturers generally use an individual annotation of the data.</p> <p>If the data is disregarded, the drive and/or the servo controller may be damaged.</p> <ul style="list-style-type: none"> ● Observe the listed units precisely and check their conformance with the units of the servo controller. ● If the units differ, make the necessary adjustment accordingly.

- ① In some servo controllers, there is a dependence between the individual parameters. We would be glad to assist you in finding the correct entries.
- ① We provide adjusted and certified quick start guides for several servo controllers. In these guides you will find the adapted parameter lists for the relevant servo converters.
- For further information, please visit our website at <http://wittenstein-alpha.de> or contact our Customer Service: service@wittenstein.de

This data reflects the technical characteristics and the limit values of the standard engines of the TPM⁺- series in general units. Possible restrictions due to the gearhead can be found in the data sheet of your servo actuator.

- Select the data for the TPM⁺- version you are using.
 - Chapter 9.4.4 "Motor data, TPM⁺ dynamic 320V, i = 16 – 31"
 - Chapter 9.4.5 "Motor data, TPM⁺ dynamic 320V, i = 61 – 91"
 - Chapter 9.4.6 "Motor data, TPM⁺ high torque 320V"
 - Chapter 9.4.7 "Motor data, TPM⁺ power 320V"
 - Chapter 9.4.8 "Motor data, TPM⁺ dynamic 560V, i = 16 – 31"
 - Chapter 9.4.9 "Motor data, TPM⁺ dynamic 560V, i = 61 – 91"
 - Chapter 9.4.10 "Motor data, TPM⁺ high torque 560V"

- Chapter 9.4.11 "Motor data, TPM⁺ power 560V, i = 4 – 35"
- Chapter 9.4.12 "Motor data, TPM⁺ power 560V, i = 40 – 100"
- Select the appropriate product size of the desired servo controller in regard to the application data.

7 Maintenance and disposal

- Read the general safety instructions before beginning work (see Chapter 2.7 "General safety instructions").

	⚠ WARNING
	<p>The permanent magnets of the rotor send a strong magnetic field, which becomes active during the disassembling of the servo actuator.</p> <ul style="list-style-type: none"> • Observe the general safety instructions (e.g. for pacemaker patients) for working in strong magnetic fields.

7.1 Maintenance work

	<p>The partial or complete disassembly of the actuator into its individual parts for maintenance or repair work is not permissible.</p> <ul style="list-style-type: none"> • In case of a malfunction or failure, please contact Customer Service.
--	--

7.1.1 Refreshment of holding brake

The holding torques of the holding brakes used in the actuators are influenced by various factors, e.g. oxidation of abraded particles, flattening of friction surfaces due to frequent application of the brakes in the same position or air gap changes due to wear. This can lead to a tolerance in the holding torque of - 50 % to + 100 %.

The specified holding torques apply under optimal conditions, without damaging influences. The deterioration of the holding torque can be reduced by refreshing the brakes periodically.

For critical applications we recommend dimensioning for an adequately large holding torque to take account of these factors. Our internal technical service would be glad to help you with the appropriate dimensioning.

A maintenance interval of 4 weeks is recommended for common industrial applications.

For your dimensioning, observe the effective torques during running-in.

Recommended brake refreshment cycle, TPM+						
For TPM+ dynamic						
	Unit	TPM 004	TPM 010	TPM 025	TPM 050	TPM 110
Slipping speed	rpm	200	200	100	100	100
Duration for brake de-energized	sec	0.5	0.5	0.5	0.5	0.5
Duration for brake energized	sec	0.5	0.5	0.5	0.5	0.5
Number of cycles	–	3	3	5	5	5

Tbl-5: TPM+ dynamic

For TPM+ power						
	Unit	TPMP 004	TPMP 010	TPMP 025	TPMP 050	TPMP 110
Slipping speed	rpm	200	100	100	100	25
Duration for brake de-energized	sec	0.5	0.5	0.5	0.5	0.5
Duration for brake energized	sec	0.5	0.5	0.5	0.5	0.5
Number of cycles	–	3	5	5	5	5

Tbl-6: TPM+ power

For TPM+ high torque						
	Unit	TPMA 004	TPMA 010	TPMA 025	TPMA 050	TPMA 110
					i=22–88	i=110–220
Slipping speed	rpm	100	100	100	25	100
Duration for brake de-energized	sec	0.5	0.5	0.5	0.5	0.5
Duration for brake de-energized	sec	0.5	0.5	0.5	0.5	0.5
Number of cycles	–	5	5	5	5	5

Tbl-7: TPM+ high torque

7.1.2 Visual inspection

- Check the entire servo actuator and all cables for exterior damage.
- The radial shaft seals are subject to wear. Therefore, also check the servo actuator for leakage during each visual inspection (lubricant leaks).
 - ① You can find more general information on radial shaft seals on our partner's Internet site at <http://www.simrit.de>.
 - ① Check the mounting position, so that no foreign medium (e.g. oil) has collected on the output flange.
- Check whether the safety signs (see Chapter 2.8 "Safety signs") and the type plate (see Chapter 3.1 "Identification plate") are mounted and legible.

7.1.3 Checking the tightening torques

- Check the tightening torque of the fastening screws on the servo actuator housing and at the output flange.
 - ① The prescribed tightening torques can be found in Chapter 9.1 "Specifications on mounting onto a machine", Tables "Tbl-11" and "Tbl-12", and in Chapter 9.2 "Specifications on mounting on the gear output side", Tables "Tbl-13", "Tbl-14" and "Tbl-15".
- If, while checking the tightening torque, you discover that a screw can be further tightened, follow the instructions in "Remounting the screw".

Remounting the screw

	<ul style="list-style-type: none"> ● Make sure that it is possible to remount the screw on the gearhead without damaging the entire machine.
--	---

- Loosen the screw.
- Remove the glue residue from the threaded bore and the screw.
- De-grease the screw.
- Coat the screw with a threadlocker (e.g. Loctite[®] 243).
- Screw in the screw and tighten it with the prescribed tightening torque.

7.1.4 Cleaning

	NOTICE
	<p>Pressurized air can damage the servo actuator seals.</p> <ul style="list-style-type: none"> ● Do not use pressurized air to clean the servo actuator.

- Clean the servo actuator using a clean, lint-free cloth.
- If necessary, use a suitable fat dissolving but non-aggressive cleaning agent.

7.2 Startup after maintenance work

- Clean the outside of the servo actuator.
- Attach all safety devices.
- Do a trial run before releasing the servo actuator again for operation.

7.3 Maintenance schedule

Maintenance work	At startup	After 500 operating hours or 3 months	Every 4 weeks	Yearly
Refreshment of holding brake			X	
Visual inspection and cleaning	X	X		X
Checking the tightening torques	X	X		X

Tbl-8: Maintenance schedule

7.4 Information on the lubricant used

	<p>All servo actuators are permanently lubricated by the manufacturer with synthetic gear oil (polyglycols) of viscosity class ISO VG100, ISO VG220 or with a high-performance lubricant (see type plate). All bearings are lubricated for life at the factory.</p>
---	---

The manufacturer listed below will provide any further information on the lubricants:

Standard lubricants	Lubricants for the food industry (NSF-H1 registered)
Castrol Industrie GmbH, Mönchengladbach Tel.: + 49 2161 909-30 www.castrol.com	Klüber Lubrication München KG, Munich Tel.: + 49 89 7876-0 www.klueber.com

Tbl-9: Lubricant manufacturers

7.5 Disposal

Consult our Customer Service Department for supplementary information on disassembly and disposal of the servo actuator.

- Dispose of the servo actuator at the recycling sites intended for this purpose.
 - ① Observe the locally valid regulations for disposals.

8 Malfunctions

	NOTICE
	<p>Changed operational behavior can be an indication of existing damage to the servo actuator, or cause damage to the servo actuator.</p> <ul style="list-style-type: none"> Do not put the servo actuator back into operation until the cause of the malfunction has been rectified.

	<p>Rectifying of malfunctions may only be done by specially trained technicians.</p>
	<p>To facilitate troubleshooting and the optimization of controller settings, it is useful to record the current over a full cycle (a servo controller function) and make it available as a file.</p>

Fault	Possible cause	Solution
Increased operating temperature	Selected construction too weak for task, nominal operating exceeded.	Check the technical specifications.
	Motor is heating the gearhead.	Check the controller's settings.
	Ambient temperature too high.	Ensure adequate cooling.
Increased operating noises	Damaged bearings	Consult our Customer Service department.
	Damaged gear teeth	
Loss of lubricant	Lubricant quantity too high	Wipe off discharged lubricant and continue to watch the gearhead. Lubricant discharge should stop after a short time.
	Seals not tight	Consult our Customer Service department.
Motor does not start	Power supply interrupted	Check the connections
	Wiring of motor and / or encoder not correct	Check the wiring of the motor phases and the motor encoder
	Blown fuse	Check for errors and replace the fuse
	Incorrect controller parameters	Check that the motor parameters are suitable for the implemented servo actuator
	Motor protection has been triggered	Check for errors. Check whether the motor protection setting is correct.
Wrong direction of rotation	Wrong set value specification for the servo controller	Check servo controller/converter. Check the set value specifications and the polarities

Fault	Possible cause	Solution
Motor is droning and has a high power consumption	Drive is blocked	Check the drive
	Error in the encoder line	Check the encoder line
	Incorrect controller parameters	Check that the motor parameters are suitable for the implemented servo actuator
	Brake does not release	(see fault "Brake does not release")
Brake does not release	Voltage drop along the supply line > 10%	Ensure that the supply voltage is correct. Check the cable cross-section.
	Incorrect brake connection	Check the connection for correct polarity and voltage
	Short circuit in the coil or at body of brake coil	Consult our Customer Service department.
Holding brake slips	Stopping torque of the brake exceeded	Check the construction plan. Carry out a refreshment.
Acceleration times are not met	Load is too high	Check the dimensioning
	Power limiting active	Check the controller parameters
Position error	Shielding of the encoder line insufficient	Inspect the shielding of the connection cables
	Disturbing pulse from the brake, protective circuit of the brake missing or defective	Check the protective circuit (e.g. Varistor) of the brake on the converter
	Mechanical coupling between the motor shaft and encoder defective	Consult our Customer Service department.

Tbl-10: Malfunctions

9 Appendix

In case of questions on the special applications, please contact **WITTENSTEIN alpha GmbH**.

9.1 Specifications on mounting onto a machine

9.1.1 Specifications for the TPM⁺ dynamic/TPM⁺ power version

Through-holes in the servo actuator housing TPM ⁺ dynamic/TPM ⁺ power				
Type/Size	Bore Ø [mm]	Quantity x diameter [] x [mm]	For screw size / property class	Tightening torque [Nm]
TPM ⁺ 004	79	8 x 4.5	M4 / 12.9	4.55
TPM ⁺ 010	109	8 x 5.5	M5 / 12.9	9.0
TPM ⁺ 025	135	8 x 5.5	M5 / 12.9	9.0
TPM ⁺ 050	168	12 x 6.6	M6 / 12.9	15.4
TPM ⁺ 110	233	12 x 9.0	M8 / 12.9	37.3

Tbl-11: Specifications on mounting onto a machine, TPM⁺ dynamic / TPM⁺ power

9.1.2 Specifications for the TPM⁺ high torque version

Through-holes in the servo actuator housing TPM ⁺ high torque				
Type/Size	Holecircle Ø [mm]	Quantity x diameter [] x [mm]	For screw size / property class	Tightening torque [Nm]
TPM ⁺ 010	109	16 x 5.5	M5 / 12.9	9.0
TPM ⁺ 025	135	16 x 5.5	M5 / 12.9	9.0
TPM ⁺ 050	168	24 x 6.6	M6 / 12.9	15.4
TPM ⁺ 110	233	24 x 9.0	M8 / 12.9	37.3

Tbl-12: Specifications on mounting onto a machine, TPM⁺ high torque

9.2 Specifications on mounting on the gear output side

9.2.1 Thread in output flange, TPM⁺ dynamic

Type/Size	Indexbore Øx depth [mm] x [mm]	Bore Ø [mm]	Quantity x Thread x Depth [] x [mm] x [mm]	Tightening torque [Nm] Property class 12.9
TPM ⁺ 004	5 H 7 x 8	31.5	7 x M5 x 7	9.0
TPM ⁺ 010	6 H 7 x 7	50.0	7 x M6 x 10	15.4
TPM ⁺ 025	6 H 7 x 7	63.0	11 x M6 x 12	15.4
TPM ⁺ 050	8 H 7 x 10	80.0	11 x M8 x 15	37.3
TPM ⁺ 110	10 H 7 x 12	125.0	11 x M10 x 20	73.4

Tbl-13: Thread in output flange (ISO9409), TPM⁺ dynamic

9.2.2 Thread in output flange, TPM⁺ high torque

Type/Size	Bore Ø [mm]	Quantity x Thread x Depth [] x [mm] x [mm]	Tightening torque [Nm] Property class 12.9
TPM ⁺ 010	50.0	12 x M6 x 10	15.4
TPM ⁺ 025	63.0	12 x M8 x 12	37.3
TPM ⁺ 050	80.0	12 x M10 x 15	73.4
TPM ⁺ 110	125.0	12 x M12 x 19	126.0

Tbl-14: Thread in output flange (ISO9409), TPM⁺ high torque

9.2.3 Thread in output flange, TPM⁺ power

Type/Size	Bore Ø [mm]	Quantity x Thread x Depth [] x [mm] x [mm]	Tightening torque [Nm] Property class 12.9
TPM ⁺ 004	31.5	8 x M5 x 7	9.0
TPM ⁺ 010	50.0	8 x M6 x 10	15.4
TPM ⁺ 025	63.0	12 x M6 x 12	15.4
TPM ⁺ 050	80.0	12 x M8 x 15	37.3
TPM ⁺ 110	125.0	12 x M10 x 20	73.4

Tbl-15: Thread in output flange (ISO9409), TPM⁺ power

9.3 Tightening torques for common thread sizes in general mechanical engineering

The specified tightening torques for headless screws and nuts are calculated values and are based on the following conditions:

- Calculation in accordance with VDI 2230 (February 2003 version)
- Friction value for thread and contact surfaces $\mu=0.10$
- Exploitation of the yield stress 90%
- Torque tools type II classes A and D in accordance with ISO 6789

The settings are values rounded to usual commercial scale gradations or setting possibilities.

- Set these values **precisely** on the scale.

Property class Screw / nut	Tightening torque [Nm] with thread												
	M3	M4	M5	M6	M8	M10	M12	M14	M16	M18	M20	M22	M24
8.8 / 8	1.15	2.64	5.2	9.0	21.5	42.5	73.5	118	180	258	362	495	625
10.9 / 10	1.68	3.88	7.6	13.2	32.0	62.5	108	173	264	368	520	700	890
12.9 / 12	1.97	4.55	9.0	15.4	37.5	73.5	126	202	310	430	605	820	1040

Tbl-16: Tightening torques for headless screws and nuts

9.4 Technical specifications

9.4.1 Moments of inertia TPM⁺ dynamic

(Total moment of inertia in respect to the motor shaft)

Moments of inertia without brake with resolver [kgcm ²]					
Ratio	TPM ⁺ 004	TPM ⁺ 010	TPM ⁺ 025	TPM ⁺ 050	TPM ⁺ 110
16	0.21	0.32	2.16	9.07	13.14
21	0.2	0.32	2.16	9.07	13.14
31	0.2	0.32	2.17	8.94	12.84
61	0.12	0.17	0.77	2.51	8.89
64	0.11	0.17	0.76	2.49	8.83
91	0.12	0.17	0.76	2.49	8.83
Moments of inertia with brake with resolver [kgcm ²]					
Ratio	TPM ⁺ 004	TPM ⁺ 010	TPM ⁺ 025	TPM ⁺ 050	TPM ⁺ 110
16	0.23	0.34	2.35	10.07	14.14
21	0.23	0.34	2.35	10.07	14.14
31	0.22	0.34	2.36	9.93	13.84
61	0.14	0.19	0.96	3.51	9.88
64	0.13	0.19	0.95	3.49	9.83
91	0.14	0.19	0.95	3.49	9.83

Tbl-17: Moments of inertia TPM⁺ dynamic

9.4.2 Moments of inertia TPM⁺ high torque

(Total moment of inertia in respect to the motor shaft)

Moments of inertia without brake with resolver [kgcm ²]				
Ratio	TPM ⁺ 010	TPM ⁺ 025	TPM ⁺ 050	TPM ⁺ 110
22	2.06	9.01	23.8	220.37
27.5	2.03	8.83	23.35	218.91
38.5	2.01	8.74	22.99	217.63
55	1.99	8.69	22.81	216.94
66	–	2.03	9.23	111.82
88	2.01	1.96	9.04	108.24
110	2.0	1.93	8.84	22.86
154	0.68	1.91	8.74	22.48
220	0.67	1.89	8.69	22.25

Moments of inertia with brake with resolver [kgcm ²]				
Ratio	TPM ⁺ 010	TPM ⁺ 025	TPM ⁺ 050	TPM ⁺ 110
22	2.25	10.0	25.6	236.87
27.5	2.22	9.83	25.15	235.41
38.5	2.2	9.74	24.79	234.13
55	2.18	9.69	24.61	233.44
66	–	2.22	10.22	128.82
88	2.2	2.15	10.03	125.24
110	2.19	2.12	9.83	24.66
154	0.87	2.1	9.74	24.28
220	0.86	2.08	9.69	24.05

Tbl-18: Moments of inertia TPM⁺ high torque

9.4.3 Moments of inertia TPM⁺ power

(Total moment of inertia in respect to the motor shaft)

Moments of inertia without brake with resolver [kgcm ²]					
Ratio	TPM ⁺ 004	TPM ⁺ 010	TPM ⁺ 025	TPM ⁺ 050	TPM ⁺ 110
4	0.39	2.38	9.98	26.42	141.73
5	0.36	2.22	9.5	24.8	131.91
7	0.33	2.08	9.07	23.34	123
10	0.31	2	8.84	22.54	118.12
16	0.32	2.02	8.94	23.07	116.99
20	0.31	1.99	8.83	22.61	116.7
25	0.31	1.98	8.81	22.55	116.3
28	0.31	1.96	8.72	22.2	115.05
35	0.31	1.96	8.71	22.17	114.85
40	0.16	0.72	2.48	6.3	60.23
50	0.16	0.72	2.48	6.28	60.13
70	0.16	0.72	2.48	6.27	60.04
100	0.16	0.72	2.47	6.26	59.99
Moments of inertia with brake with resolver [kgcm ²]					
Ratio	TPM ⁺ 004	TPM ⁺ 010	TPM ⁺ 025	TPM ⁺ 050	TPM ⁺ 110
4	0.41	2.57	10.98	28.22	158.73
5	0.38	2.41	10.5	26.6	148.91
7	0.35	2.27	10.07	25.14	140
10	0.34	2.19	9.84	24.34	135.12
16	0.34	2.21	9.94	24.87	133.99
20	0.34	2.18	9.82	24.41	133.7
25	0.34	2.17	9.8	24.35	133.3

Moments of inertia with brake with resolver [kgcm ²]					
Ratio	TPM ⁺ 004	TPM ⁺ 010	TPM ⁺ 025	TPM ⁺ 050	TPM ⁺ 110
28	0.33	2.15	9.72	24	132.05
35	0.33	2.14	9.71	23.97	131.85
40	0.18	0.91	3.48	8.1	77.23
50	0.18	0.91	3.48	8.08	77.13
70	0.18	0.91	3.47	8.07	77.04
100	0.18	0.91	3.47	8.06	76.99

Tbl-19: Moments of inertia TPM⁺ power

9.4.4 Motor data, TPM⁺ dynamic 320V, i = 16 – 31

General data						
	Unit	TPM ⁺ 004	TPM ⁺ 010	TPM ⁺ 025	TPM ⁺ 050	TPM ⁺ 110
Stator length	mm	30	30	45	60	75
Pole pair number p	p	4	4	6	6	6
Maximum torque T _{max}	Nm	2	3.8	12.1	28.9	43.9
Maximum current I _{max} *	Aeff	5.5	9	29.4	70	70
Maximum speed	rpm	6000	6000	6000	5000	3700
Continuous stall torque T ₀	Nm	0.72	1.2	5.5	13.49	16.42
Continuous stall current I ₀ *	Aeff	1.9	2.25	9.9	23.7	16.7
Torque constant K _t	Nm/Aeff	0.4	0.56	0.56	0.58	1
Voltage constant K _e	Veff/krpm	24.4	34.1	34.3	35.4	61
Winding resistance at 20 °C terminal-terminal	Ohm	9.4	7.1	0.73	0.13	0.32
Winding inductance terminal-terminal	mH	11.1	7.33	2	1	2.4
Electrical time constant T _e	msec	1.2	1.1	2.7	6.7	7.4
Max. winding temperature θ _{max}	°C	155	155	155	155	155
* Depending on the static and dynamic loads as well as the lambda factor, the continuous stall current and the maximum current of the motor needs to be limited if necessary.						
① You can determine the design for each case with our design software cymex [®] .						

Tbl-20: Motor data, TPM⁺ dynamic 320V, i = 16 – 31

9.4.5 Motor data, TPM⁺ dynamic 320V, i = 61 – 91

General data						
	Unit	TPM ⁺ 004	TPM ⁺ 010	TPM ⁺ 025	TPM ⁺ 050	TPM ⁺ 110
Stator length	mm	15	15	15	15	60
Pole pair number p	p	4	4	6	6	6
Maximum torque T_{max}	Nm	0.98	1.9	4.4	7.8	28.9
Maximum current I_{max}^*	Aeff	4.2	5.2	10.4	21	70
Maximum speed	rpm	6000	6000	6000	5000	5000
Continuous stall torque T_0	Nm	0.36	0.67	1.86	3.59	13.49
Continuous stall current I_0^*	Aeff	1.38	1.6	3.3	6.6	23.7
Torque constant K_t	Nm/Aeff	0.27	0.45	0.59	0.56	0.58
Voltage constant K_e	Veff/krpm	16.3	27.6	35.4	33.9	35.4
Winding resistance at 20 °C terminal-terminal	Ohm	12.5	13.3	4.5	1.33	0.13
Winding inductance terminal-terminal	mH	10	10	6.3	3.7	1
Electrical time constant T_e	msec	0.4	0.8	1.4	2.8	6.7
Max. winding temperature θ_{max}	°C	155	155	155	155	155
<p>* Depending on the static and dynamic loads as well as the lambda factor, the continuous stall current and the maximum current of the motor needs to be limited if necessary.</p> <p>① You can determine the design for each case with our design software cymex[®].</p>						

Tbl-21: Motor data, TPM⁺ dynamic 320V, i = 61 – 91

9.4.6 Motor data, TPM⁺ high torque 320V

General data					
Ratio i	Unit	TPM ⁺ 010		TPM ⁺ 025	
		22 –110	154 –220	22 –55	66 –220
Stator length	mm	45	15	60	45
Pole pair number p	p	6	6	6	6
Maximum torque T_{max}	Nm	11.98	4.4	28.9	11.98
Maximum current I_{max}^*	Aeff	29.4	10.4	70.0	29.4
Maximum speed	rpm	4850	4850	4850	4850
Continuous stall torque T_0	Nm	3.75	1.44	10.92	4.19
Continuous stall current I_0^*	Aeff	8.64	3.33	22.66	9.98
Torque constant K_t	Nm/Aeff	0.48	0.47	0.56	0.48
Voltage constant K_e	Veff/krpm	29.0	28.4	34.2	29.0

General data					
	Unit	TPM ⁺ 010		TPM ⁺ 025	
Ratio i		22 –110	154 –220	22 –55	66 –220
Winding resistance at 20 °C terminal-terminal	Ohm	0.81	5.23	0.16	0.81
Winding inductance terminal-terminal	mH	2.0	6.3	1.0	2.0
Electrical time constant T_e	msec	2.5	1.2	6.4	2.5
Max. winding temperature θ_{max}	°C	155	155	155	155
* Depending on the static and dynamic loads as well as the lambda factor, the continuous stall current and the maximum current of the motor needs to be limited if necessary.					
① You can determine the design for each case with our design software cymex [®] .					

Tbl-22: Motor data, TPM⁺ high torque 320V9.4.7 Motor data, TPM⁺ power 320V

General data							
	Unit	TPM ⁺ 004		TPM ⁺ 010		TPM ⁺ 025	
Ratio i		4 –35	40 –100	4 –35	40 –100	4 –35	40 –100
Stator length	mm	30	15	45	15	60	15
Pole pair number p	p	4	4	6	6	6	6
Maximum torque T_{max}	Nm	3.8	1.9	12.1	4.4	28.9	7.8
Maximum current I_{max}^*	Aeff	9	5.2	29.4	10.4	70	21
Maximum speed	rpm	6000	6000	6000	6000	6000	6000
Continuous stall torque T_0	Nm	1.25	0.66	4.5	1.38	11.68	3
Continuous stall current I_0^*	Aeff	2.7	1.73	9.35	3.22	23.73	6.93
Torque constant K_t	Nm/Aeff	0.56	0.45	0.56	0.59	0.58	0.56
Voltage constant K_e	Veff/krpm	34.1	27.6	34.3	35.4	35.4	33.9
Winding resistance at 20 °C terminal-terminal	Ohm	7.1	13.3	0.73	4.5	0.13	1.33
Winding inductance terminal-terminal	mH	7.33	10	2	6.3	1	3.7
Electrical time constant T_e	msec	1.1	0.8	2.7	1.4	6.7	2.8
Max. winding temperature θ_{max}	°C	155	155	155	155	155	155
* Depending on the static and dynamic loads as well as the lambda factor, the continuous stall current and the maximum current of the motor needs to be limited if necessary.							
① You can determine the design for each case with our design software cymex [®] .							

Tbl-23: Motor data, TPM⁺ power 320V

9.4.8 Motor data, TPM⁺ dynamic 560V, i = 16 – 31

General data						
	Unit	TPM ⁺ 004	TPM ⁺ 010	TPM ⁺ 025	TPM ⁺ 050	TPM ⁺ 110
Stator length	mm	30	30	45	60	75
Pole pair number p	p	4	4	6	6	6
Maximum torque T_{max}	Nm	2	3.8	12.1	28.9	43.9
Maximum current I_{max}^*	Aeff	3.2	5.2	17	40	70
Maximum speed	rpm	6000	6000	6000	5000	5000
Continuous stall torque T_0	Nm	0.72	1.2	5.5	13.49	16.42
Continuous stall current I_0^*	Aeff	1.1	1.3	5.7	13.7	16.7
Torque constant K_t	Nm/Aeff	0.7	0.97	0.98	1	1
Voltage constant K_e	Veff/krpm	42.2	58.5	59.5	61	61
Winding resistance at 20 °C terminal-terminal	Ohm	28.2	21.3	2.2	0.45	0.32
Winding inductance terminal-terminal	mH	33.3	22.8	6	3	2.4
Electrical time constant T_e	msec	1.2	1.1	2.7	6.7	7.4
Max. winding temperature θ_{max}	°C	155	155	155	155	155
<p>* Depending on the static and dynamic loads as well as the lambda factor, the continuous stall current and the maximum current of the motor needs to be limited if necessary.</p> <p>① You can determine the design for each case with our design software cymex[®].</p>						

Tbl-24: Motor data, TPM⁺ dynamic 560V, i = 16 – 31

9.4.9 Motor data, TPM⁺ dynamic 560V, i = 61 – 91

General data						
	Unit	TPM ⁺ 004	TPM ⁺ 010	TPM ⁺ 025	TPM ⁺ 050	TPM ⁺ 110
Stator length	mm	15	15	15	15	60
Pole pair number p	p	4	4	6	6	6
Maximum torque T_{max}	Nm	0.98	1.9	4.4	7.8	28.9
Maximum current I_{max}^*	Aeff	2.4	3	6	12	40
Maximum speed	rpm	6000	6000	6000	5000	5000
Continuous stall torque T_0	Nm	0.36	0.67	1.86	3.59	13.49
Continuous stall current I_0^*	Aeff	0.8	0.9	1.9	3.8	13.7
Torque constant K_t	Nm/Aeff	0.47	0.78	1.02	0.97	1
Voltage constant K_e	Veff/krpm	28.3	47.4	61.3	58.7	61

General data						
	Unit	TPM ⁺ 004	TPM ⁺ 010	TPM ⁺ 025	TPM ⁺ 050	TPM ⁺ 110
Winding resistance at 20 °C terminal-terminal	Ohm	37.4	40	13.5	4	0.45
Winding inductance terminal-terminal	mH	30	30	18.9	11.1	3
Electrical time constant T _e	msec	0.8	0.8	1.4	2.8	6.7
Max. winding temperature θ_{\max}	°C	155	155	155	155	155
<p>* Depending on the static and dynamic loads as well as the lambda factor, the continuous stall current and the maximum current of the motor needs to be limited if necessary.</p> <p>① You can determine the design for each case with our design software cymex[®].</p>						

TbI-25: Motor data, TPM⁺ dynamic 560V, i = 61 – 91

9.4.10 Motor data, TPM⁺ high torque 560V

General data										
	Unit	TPM ⁺ 010		TPM ⁺ 025		TPM ⁺ 050		TPM ⁺ 110		
Ratio i		22 – 110	154 – 220	22 – 55	66 – 220	22 – 55	66 – 220	22 – 55	66 – 88	110 – 220
Stator length	mm	45	15	60	45	60	60	120	60	60
Pole pair number p	p	6	6	6	6	6	6	6	6	6
Maximum torque T _{max}	Nm	11.98	4.4	28.9	11.98	56.6	28.9	164.5	88	56.6
Maximum current I _{max} *	A _{eff}	17	6	40	17	63.5	40	160	100	63.5
Maximum speed	rpm	4850	4850	4850	4850	4500	4850	4150	4150	4500
Continuous stall torque T ₀	Nm	3.75	1.44	10.92	4.19	19.28	11.11	63.6	40.35	22.18
Continuous stall current I ₀ *	A _{eff}	4.99	1.92	13.08	5.76	17.93	12.6	53.7	40.85	20.5
Torque constant K _t	Nm/ A _{eff}	0.83	0.82	0.98	0.83	1.21	1.0	1.17	1.09	1.19
Voltage constant K _e	V _{eff} / krpm	50.3	49.2	59.2	50.3	73.4	61.0	70.9	66.1	71.9
Winding resistance at 20 °C terminal-terminal	Ohm	2.36	15.7	0.47	2.36	0.29	0.47	0.05	0.08	0.29

General data										
	Unit	TPM ⁺ 010		TPM ⁺ 025		TPM ⁺ 050		TPM ⁺ 110		
Ratio i		22 – 110	154 – 220	22 – 55	66 – 220	22 – 55	66 – 220	22 – 55	66 – 88	110 – 220
Winding inductance terminal-terminal	mH	6	18.9	3	6	2.1	3	0.67	0.9	2.1
Electrical time constant T _e	msec	2.5	1.2	6.4	2.5	7.3	6.4	14	10.8	7.2
Max. winding temperature θ_{\max}	°C	155	155	155	155	155	155	155	155	155
<p>* Depending on the static and dynamic loads as well as the lambda factor, the continuous stall current and the maximum current of the motor needs to be limited if necessary.</p> <p>① You can determine the design for each case with our design software cymex[®].</p>										

Tbl-26: Motor data, TPM⁺ high torque 560V

9.4.11 Motor data, TPM⁺ power 560V, i = 4 – 35

General data						
	Unit	TPM ⁺ 004	TPM ⁺ 010	TPM ⁺ 025	TPM ⁺ 050	TPM ⁺ 110
Stator length	mm	30	45	60	60	60
Pole pair number p	p	4	6	6	6	6
Maximum torque T _{max}	Nm	3.8	12.1	28.9	56.6	88
Maximum current I _{max} [*]	A _{eff}	5.2	17	40	63.5	100
Maximum speed	rpm	6000	6000	6000	5000	4200
Continuous stall torque T ₀	Nm	1.25	4.5	11.68	19.3	36.9
Continuous stall current I ₀ [*]	A _{eff}	1.56	5.4	13.7	19	38.6
Torque constant K _t	Nm/A _{eff}	0.97	0.98	1	1.19	1.09
Voltage constant K _e	V _{eff} /krpm	58.5	59.5	61	71.9	66.1
Winding resistance at 20 °C terminal-terminal	Ohm	21.3	2.2	0.45	0.27	0.08
Winding inductance terminal-terminal	mH	22.8	6	3	2.1	0.9
Electrical time constant T _e	msec	1.1	2.7	6.7	8	11.2
Max. winding temperature θ_{\max}	°C	155	155	155	155	155
<p>* Depending on the static and dynamic loads as well as the lambda factor, the continuous stall current and the maximum current of the motor needs to be limited if necessary.</p> <p>① You can determine the design for each case with our design software cymex[®].</p>						

Tbl-27: Motor data, TPM⁺ power 560V, i = 4 – 35

9.4.12 Motor data, TPM⁺ power 560V, i = 40 – 100

General data						
	Unit	TPM ⁺ 004	TPM ⁺ 010	TPM ⁺ 025	TPM ⁺ 050	TPM ⁺ 110
Stator length	mm	15	15	15	15	30
Pole pair number p	p	4	6	6	6	6
Maximum torque T_{max}	Nm	1.9	4.4	7.8	15.6	44.2
Maximum current I_{max}^*	Aeff	3	6	12	33	50
Maximum speed	rpm	6000	6000	6000	5000	4500
Continuous stall torque T_0	Nm	0.66	1.38	3	5.4	20.74
Continuous stall current I_0^*	Aeff	1.0	1.86	4	7.5	21.9
Torque constant K_t	Nm/Aeff	0.78	1.02	0.97	0.91	1.08
Voltage constant K_e	Veff/krpm	47.4	61.3	58.7	55.1	65.3
Winding resistance at 20 °C terminal-terminal	Ohm	40	13.5	4	1.81	0.25
Winding inductance terminal-terminal	mH	30	18.9	11.1	5.1	1.9
Electrical time constant T_e	msec	0.8	1.4	2.8	2.8	7.6
Max. winding temperature θ_{max}	°C	155	155	155	155	155
<p>* Depending on the static and dynamic loads as well as the lambda factor, the continuous stall current and the maximum current of the motor needs to be limited if necessary.</p> <p>① You can determine the design for each case with our design software cymex[®].</p>						

Tbl-28: Motor data, TPM⁺ power 560V, i = 40 – 100

9.4.13 Technical specifications, Resolver

Ordering code: TPMxxxxx-xxxR-xxxx-xxxx-xx-xxx		
	TPM ⁺ dynamic 004	TPM ⁺ dynamic 010 – 110 TPM ⁺ high torque 010 – 110 TPM ⁺ power 004 – 110
Size	Size 08	Size 15
Type	TS2605 N31 E64	TS2620 N21 E11
Pole pair number p	1	1
Input voltage	7Veff 10kHz	7Veff 10kHz
Ratio	0.5+ -5%	0.5+ -5%
Fault	+ - 10'max	+ - 10'max
Zero voltage	20mVeff max	20mVeff max
Phase shift	+10° nominal	0° nominal

Ordering code: TPMxxxxx-xxxR-xxxx-xxxx-xx-xxx		
	TPM ⁺ dynamic 004	TPM ⁺ dynamic 010 – 110 TPM ⁺ high torque 010 – 110 TPM ⁺ power 004 – 110
Impedance ZR0	140 ohm	70 + j 100 ohm
Impedance ZS0	–	180 + j 300 ohm
Impedance ZSS	120 ohm	175 + j 257 ohm
Max. operating temperature	155 °C	155 °C

Tbl-29: Technical specifications, Resolver

9.4.14 Technical specifications Stegmann Hiperface absolute encoder

Singleturn	
Ordering code: TPMxxxxx-xxxN-xxxx-xxxx-xx-xxx	
	TPM ⁺ dynamic 004 –110 TPM ⁺ high torque 010 –110 TPM ⁺ power 004 –110
Type	SKS36
Operating voltage	7-12 V
Protocol	Hiperface
Number of SinCos periods per revolution	128
Multiturn	
Ordering code: TPMxxxxx-xxxK-xxxx-xxxx-xx-xxx	
	TPM ⁺ dynamic 004 –110 TPM ⁺ high torque 010 –110 TPM ⁺ power 004 –110
Type	SKM36
Operating voltage	7-12 V
Protocol	Hiperface
Number of SinCos periods per revolution	128
Number of Multiturn revolutions	4096

Tbl-30: Technical specifications Stegmann Hiperface

9.4.15 Technical specifications Stegmann Hiperface absolute encoder, Rockwell option

Singleturn		
Ordering code: TPM xxxx-xxxE-xxxx-xxxx-x5-xxx		
	TPM ⁺ dynamic 560V U _{DCBus}	TPM ⁺ dynamic 320V U _{DCBus}
Type	SKS36	SKS36
Operating voltage	7-12 V	5 V
Protocol	Hiperface	Hiperface
Number of SinCos periods per revolution	128	128

Multiturn		
Ordering code: TPM xxxx-xxxV-xxxx-xxxx-x5-xxx		
	TPM⁺ dynamic 560V U_{DCBus}	TPM⁺ dynamic 320V U_{DCBus}
Type	SKM36	SKM36
Operating voltage	7-12 V	5 V
Protocol	Hiperface	Hiperface
Number of SinCos periods per revolution	128	128
Number of Multiturn revolutions	4096	4096

Tbl-31: Technical specifications Stegmann Hiperface

9.4.16 Technical specifications Heidenhain EnDat absolute encoder

Singleturn EnDat	
Ordering code: TPMxxxxx-xxxS-xxxx-xxxx-xx-xxx	
	TPM⁺ dynamic 004 –110 TPM⁺ high torque 010 –110 TPM⁺ power 004 –110
Type	ECN 1113
Operating voltage	5 V
Protocol	EnDat 2.1
Distinguishable positions via EnDat protocol/revolutions	8192
Number of SinCos periods per revolution	512
Multiturn EnDat	
Ordering code: TPMxxxxx-xxxM-xxxx-xxxx-xx-xxx	
	TPM⁺ dynamic 004 –110 TPM⁺ high torque 010 –110 TPM⁺ power 004 –110
Type	EQN 1125
Operating voltage	5 V
Protocol	EnDat 2.1
Distinguishable positions via EnDat protocol/revolutions	8192
Number of SinCos periods per revolution	512
Number of Multiturn revolutions	4096

Tbl-32: Technical specifications Heidenhain EnDat

9.4.17 Technical specifications Heidenhain Incremental

Incremental	
Ordering code: TPMxxxxx-xxxI-xxxx-xxxx-xx-xxx	
	TPM ⁺ dynamic 004 –110 TPM ⁺ high torque 010 –110 TPM ⁺ power 004 –110
Type	ERN 1185
Operating voltage	5 V
Number of SinCos periods per revolution	2048

Tbl-33: Technical specifications Heidenhain Incremental

9.4.18 Technical specifications TTL Encoder incremental

TTL Encoder incremental	
Ordering code: TPMxxxxx-xxxT-xxxx-xxxx-xx-xxx	
	TPM ⁺ dynamic 004 –110 TPM ⁺ high torque 010 –110 TPM ⁺ power 004 –110
Type	Sick-Stegmann CKS36
Operating voltage	5 V
Commutation signals	The motor polar pair number appropriately programmed.
Increments per revolution	2048

Tbl-34: Technical specifications TTL Encoder incremental

9.4.19 Technical specifications temperature sensors KTY and NTC

Type	KTY 84-130	NTC P1H104
Ordering code:	TPMxxxxx-xxxx-xKxx-xxxx-xx-xxx	TPMxxxxx-xxxx-xNxx-xxxx-xx-xxx
Temperature [°C]	Resistance, type [kohm]	Resistance, type [kohm]
-30	0.391	1770
-20	0.424	971
-10	0.460	553
0	0.498	327
10	0.538	199
20	0.581	125
25	0.603	100
30	0.626	81
40	0.672	53
50	0.722	36
60	0.773	25
70	0.826	18

Type	KTY 84-130	NTC P1H104
Ordering code:	TPMxxxxx-xxxx-xKxx-xxxx-xx-xxx	TPMxxxxx-xxxx-xNxx-xxxx-xx-xxx
Temperature [°C]	Resistance, type [kohm]	Resistance, type [kohm]
80	0.882	13
90	0.940	9.2
100	1.000	6.8
110	1.062	5.2
120	1.127	3.9
130	1.194	3
140	1.262	2.4
150	1.334	1.9
160	1.407	1.5
170	1.482	1.2
180	1.560	1
190	1.640	0.8
200	1.722	0.7

TbI-35: Technical specifications temperature sensors KTY and NTC

9.4.20 Technical specifications temperature sensor PTC

PTC STM 160	
Ordering code: TPMxxxxx-xxxx-xPxx-xxxx-xx-xxx	
Deactivation in case of fault	
Characteristic line in accordance with DIN 44081/44082	
Temperature [°C]	Resistance [ohm]
< 140	20 - 250
140 - 155	250 - 550
155 - 165	550 - 1330
165 - 175	1330 - 4000
> 175	> 4000

TbI-36: Technical specifications temperature sensor PTC

9.4.21 Technical specifications brake TPM⁺ dynamic

Ordering code: TPM xxxx-xxxx-xxBx-xxxx-xx-xxx						
	Unit	TPM ⁺ 004	TPM ⁺ 010	TPM ⁺ 025	TPM ⁺ 050	TPM ⁺ 110
Voltage	V DC	24	24	24	24	24
Power consumption	A DC	0.42	0.42	0.58	0.71	0.71
Holding torque at 120 °C	Nm	1.1	1.1	4.5	13	13
Opening time	msec	11	11	30	42	42
Closing time	msec	10	10	20	20	20

Tbl-37: Technical specifications brake TPM⁺ dynamic

The listed opening and closing times are noted without the use of an additional wiring of the brake.

- ① To avoid interfering signals from the switching of the brake, in general an additional wiring, e.g. in form of a varistor, should be added. Observe the requirements for this of the applied servo controller manufacturer.

9.4.22 Technical specifications brake TPM⁺ high torque

Ordering code: TPMAxxxx-xxxx-xxBx-xxxx-xx-xxx									
	Unit	TPM ⁺ 010		TPM ⁺ 025		TPM ⁺ 050		TPM ⁺ 110	
Ratio i		22 – 110	154 – 220	22 –55	66 – 220	22 –55	66 – 220	22 – 88	110 – 220
Voltage	V DC	24	24	24	24	24	24	24	24
Power consumption	A DC	0.58	0.46	0.71	0.58	1.0	0.71	1.67	1.0
Holding torque at 120 °C	Nm	4.5	1.8	13	4.5	23	13	72	23
Opening time	msec	30	30	42	30	50	42	200	50
Closing time	msec	20	25	20	20	40	20	50	40

Tbl-38: Technical specifications brake TPM⁺ high torque

The listed opening and closing times are noted without the use of an additional wiring of the brake.

- ① To avoid interfering signals from the switching of the brake, in general an additional wiring, e.g. in form of a varistor, should be added. Observe the requirements for this of the applied servo controller manufacturer.

9.4.23 Technical specifications brake TPM⁺ power

Ordering code: TPMPxxxx-xxxx-xxBx-xxxx-xx-xxx										
	Unit	TPM ⁺ 004	TPM ⁺ 010		TPM ⁺ 025		TPM ⁺ 050		TPM ⁺ 110	
Ratio i			4 -70	100	4 -70	100	4 -70	100	4 -50	70 - 100
Voltage	V DC	24	24	24	24	24	24	24	24	24
Power consumption	A DC	0.42	0.58	0.46	0.71	0.71	1	1	1.67	1.67
Holding torque at 120 °C	Nm	1.1	4.5	1.8	13	6	23	11	72	25
Opening time	msec	11	30	30	42	42	50	50	200	140
Closing time	msec	10	20	25	20	20	40	50	50	90

Tbl-39: Technical specifications brake TPM⁺ power

The listed opening and closing times are noted without the use of an additional wiring of the brake.

- ① To avoid interfering signals from the switching of the brake, in general an additional wiring, e.g. in form of a varistor, should be added. Observe the requirements for this of the applied servo controller manufacturer.

9.4.24 Pin assignment 1

Design with resolver —output size 1 (pin assignment 1)

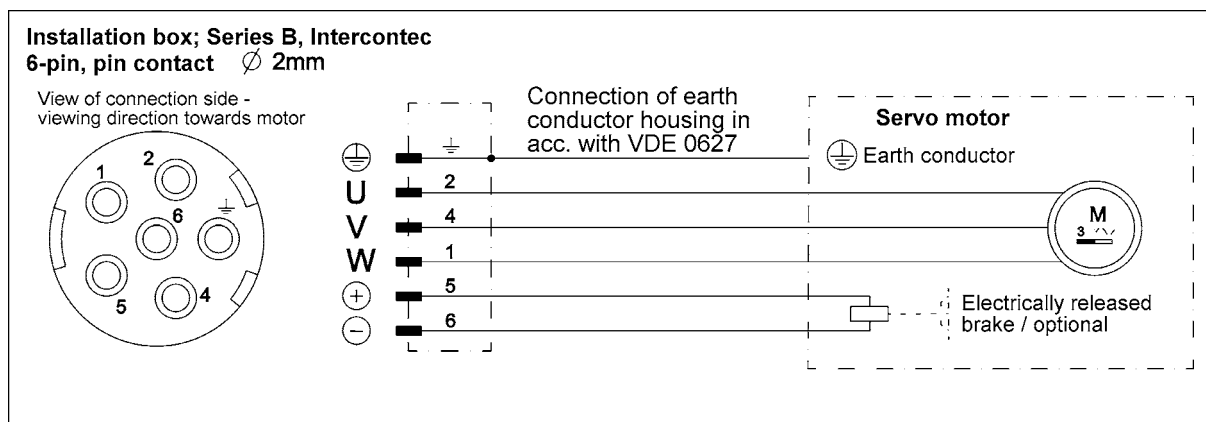

Design with resolver and optical encoder —output size 1.5 (pin assignment 1)

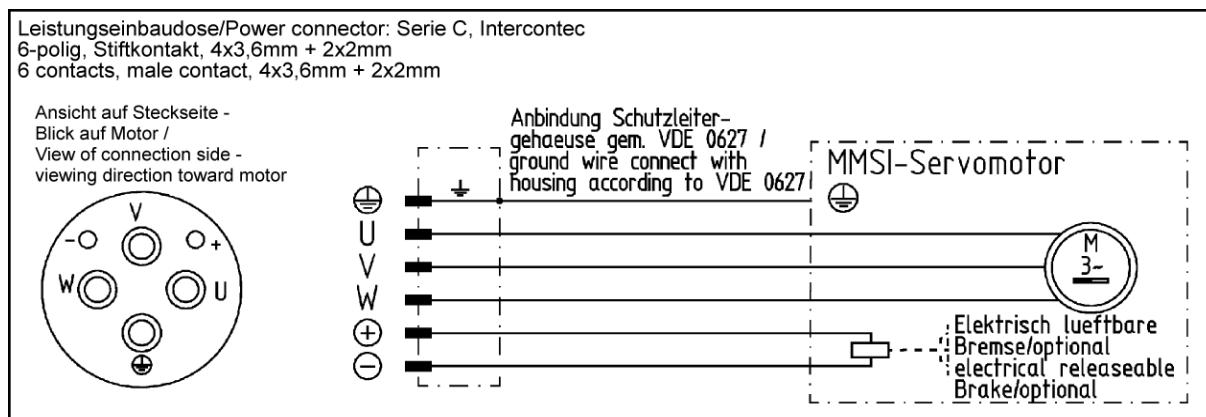

Option “R” —signal (pin assignment 1)

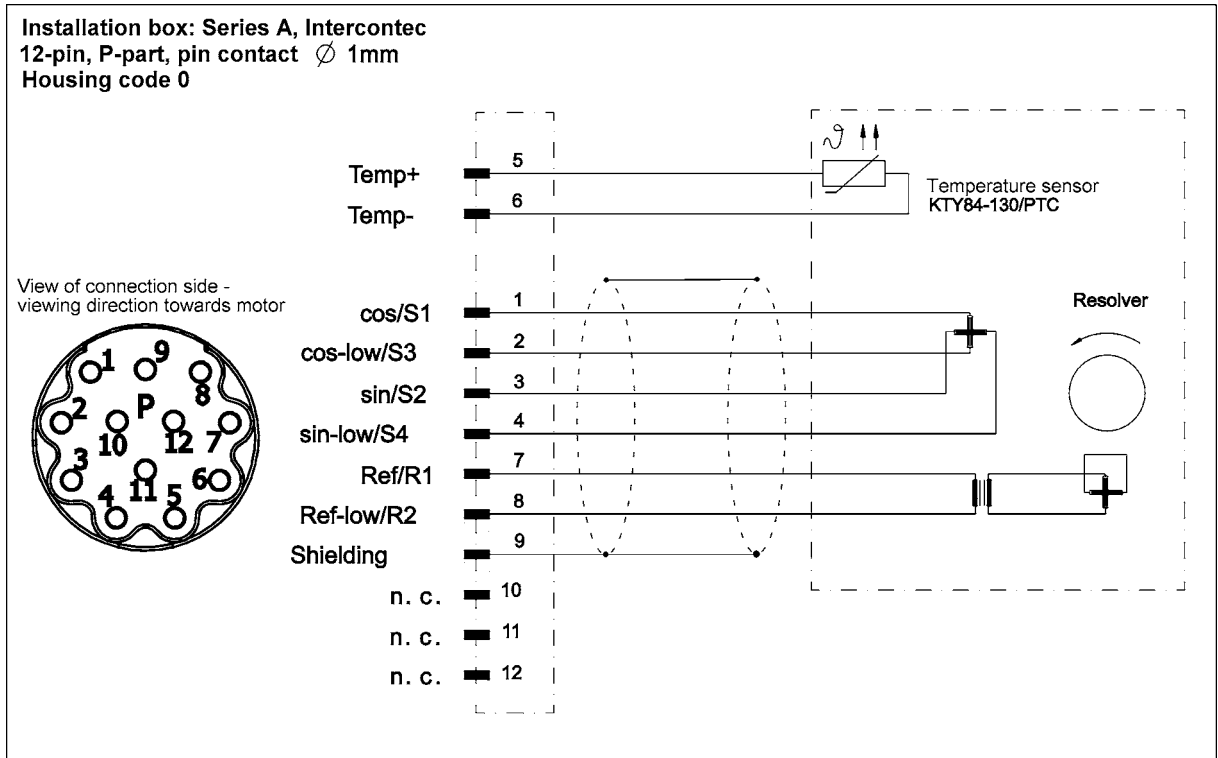

Design with optical encoder —output (pin assignment 1)

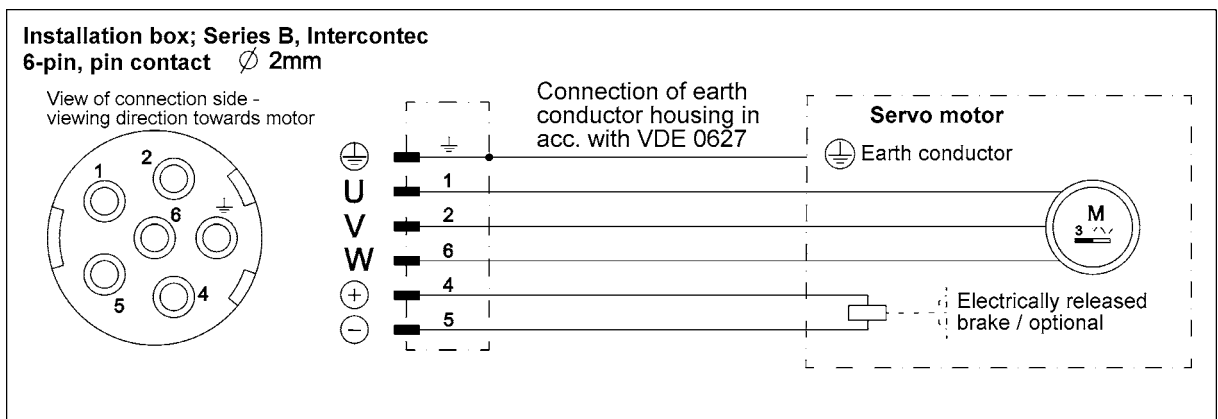

Option “N” and “K” —signal (pin assignment 1)

Installation box: Series A, Intercontec
 12-pin, P-part, pin contact \varnothing 1mm
 Housing code 0

View of connection side -
 viewing direction towards motor

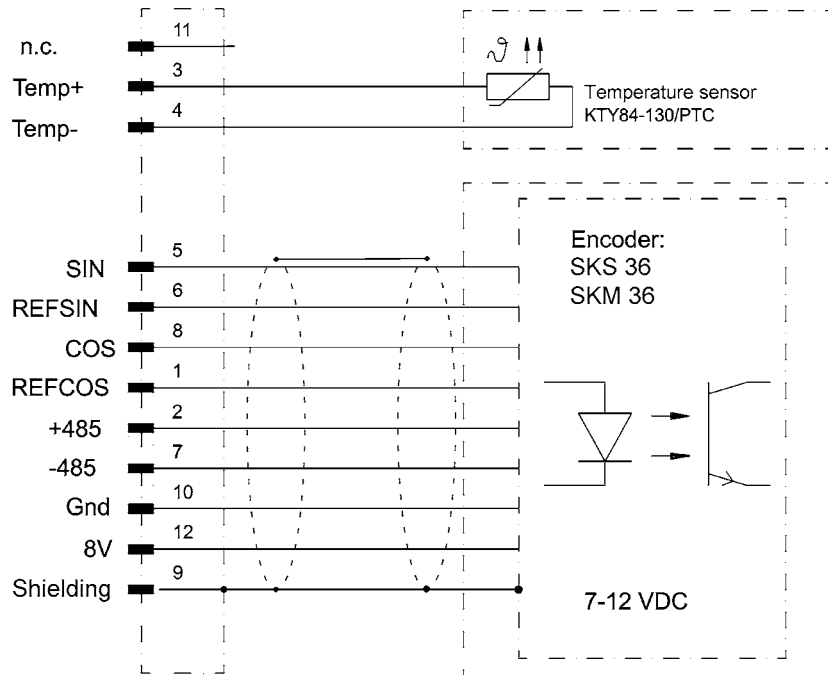
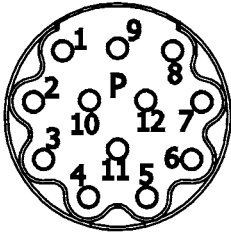

Option “S” and “M” —signal (pin assignment 1)

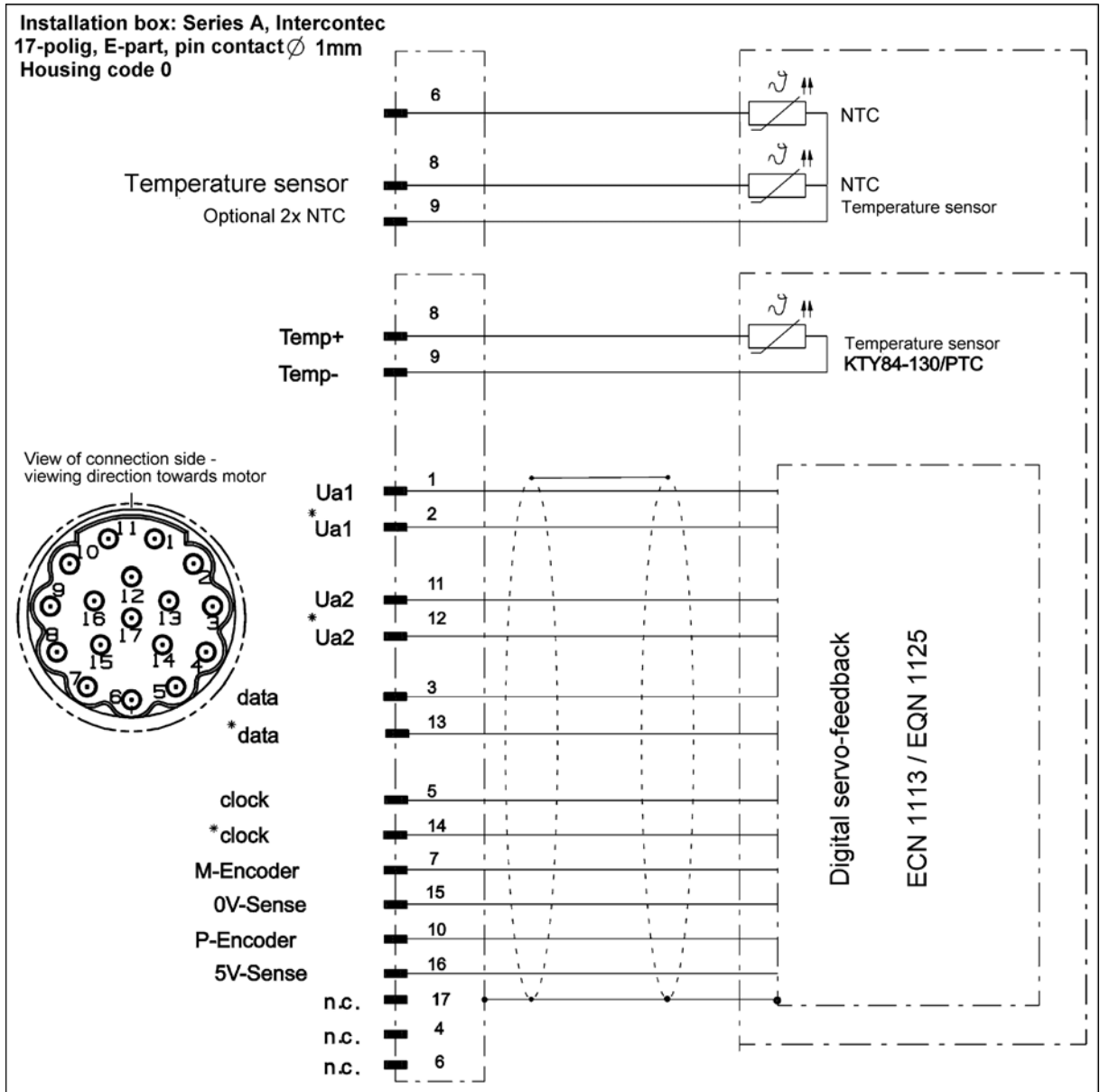

Option “T” —signal (pin assignment 1)

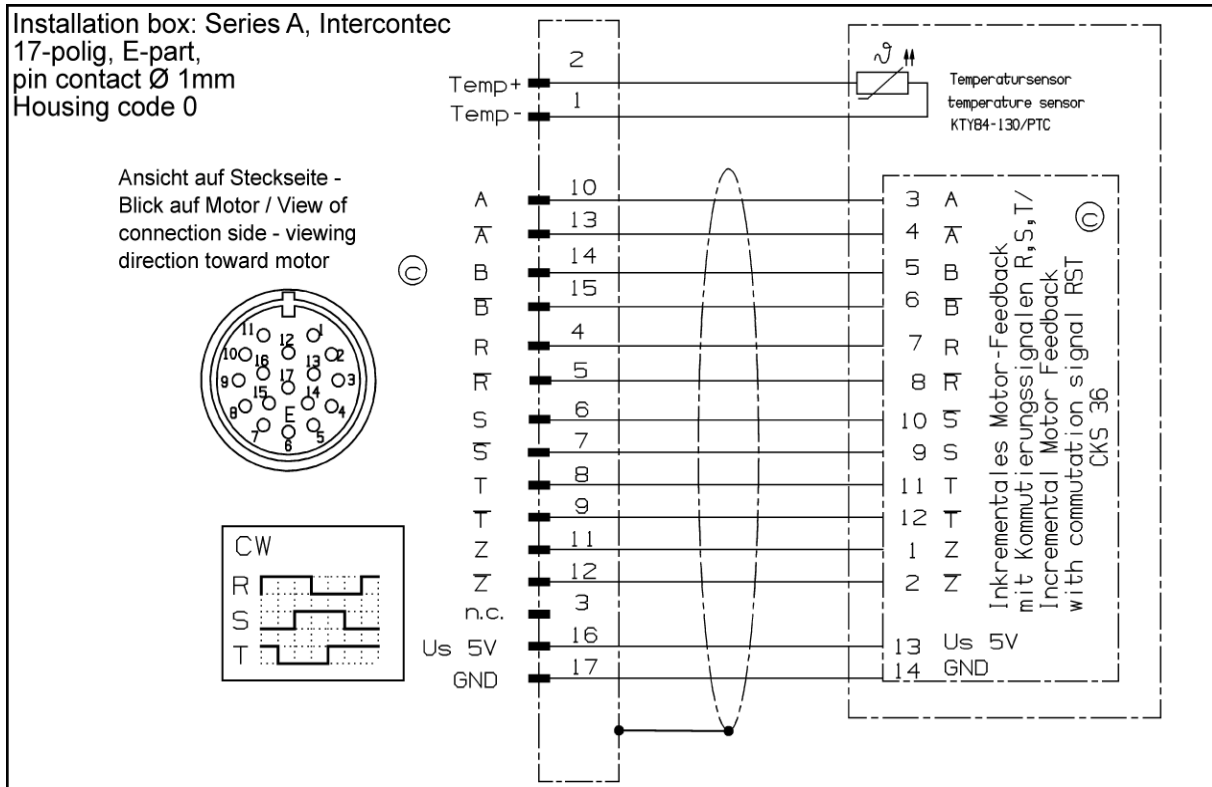

9.4.25 Pin assignment 4

Design with resolver, EnDat- and Hiperface encoder —output size 1 (pin assignment 4)

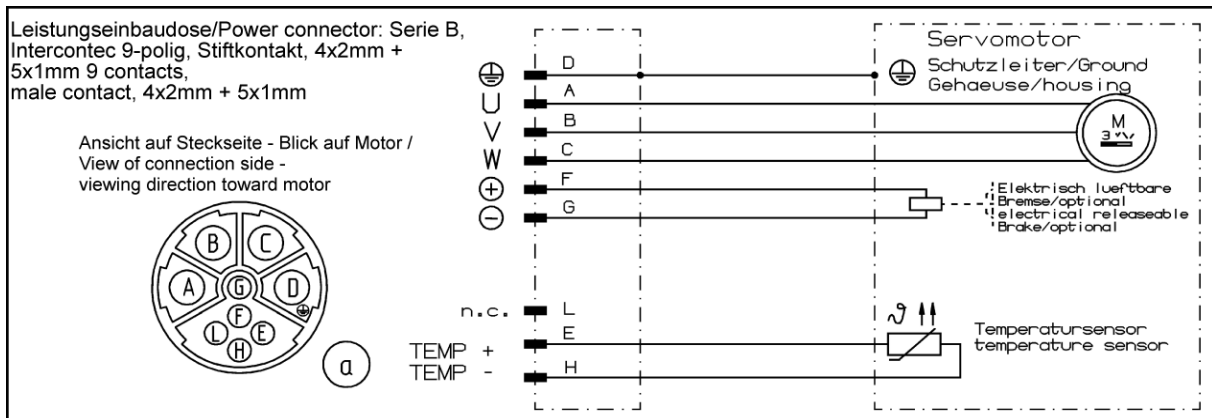

Design with resolver, EnDat- and Hiperface encoder —output size 1.5 (pin assignment 4)

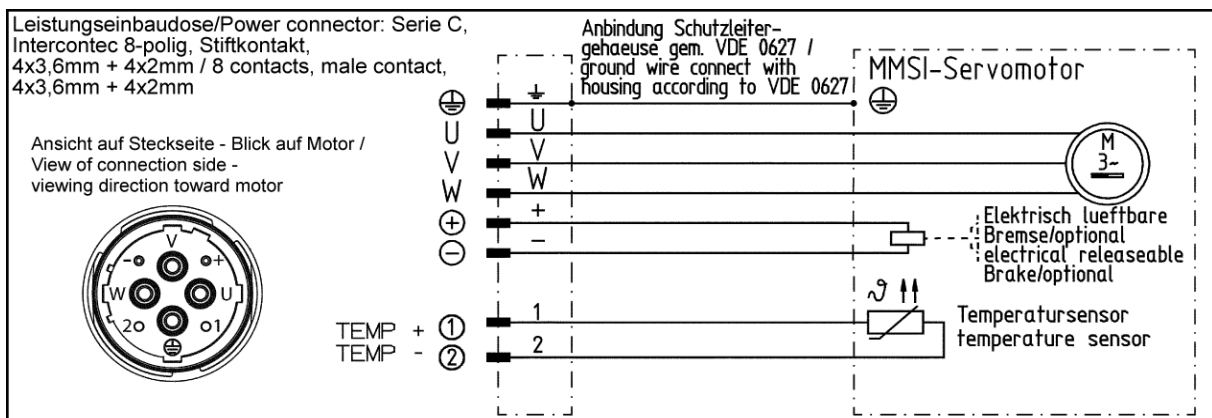

Option “S” and “M” —signal (pin assignment 4)

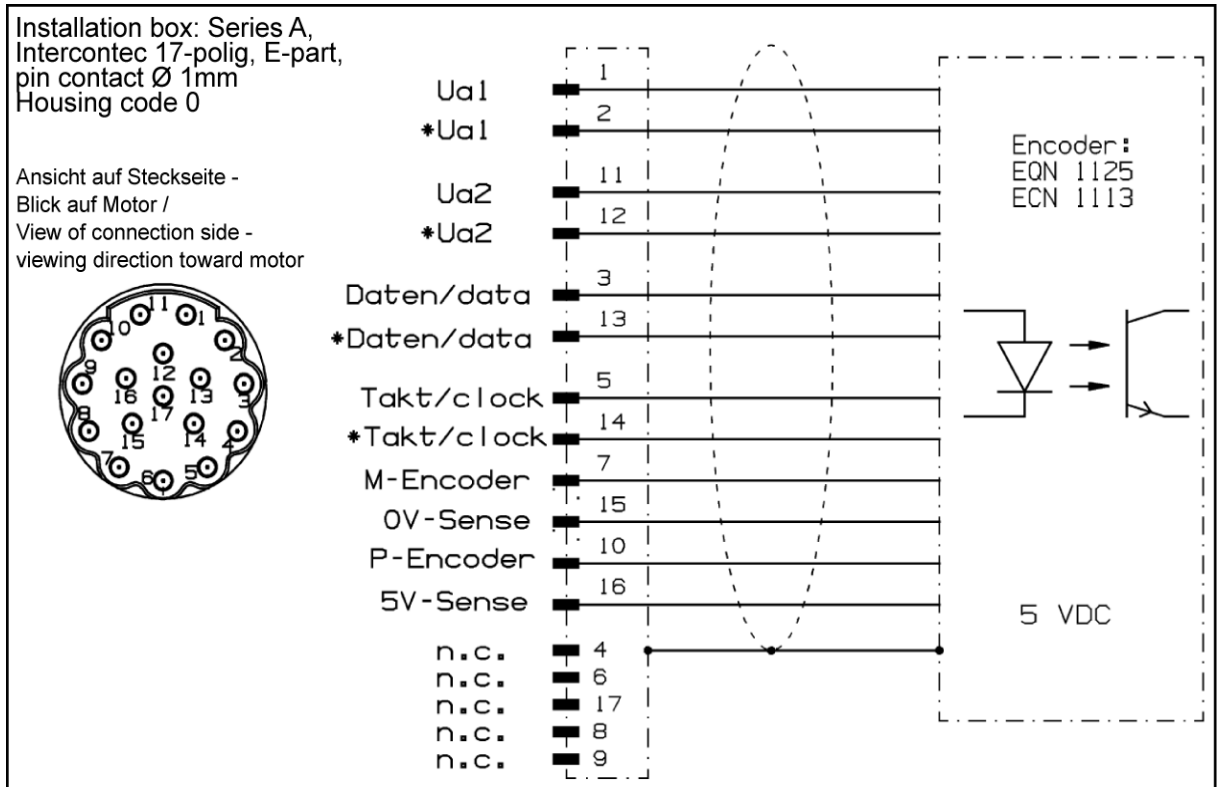

Option “N” and “K” —signal (pin assignment 4)

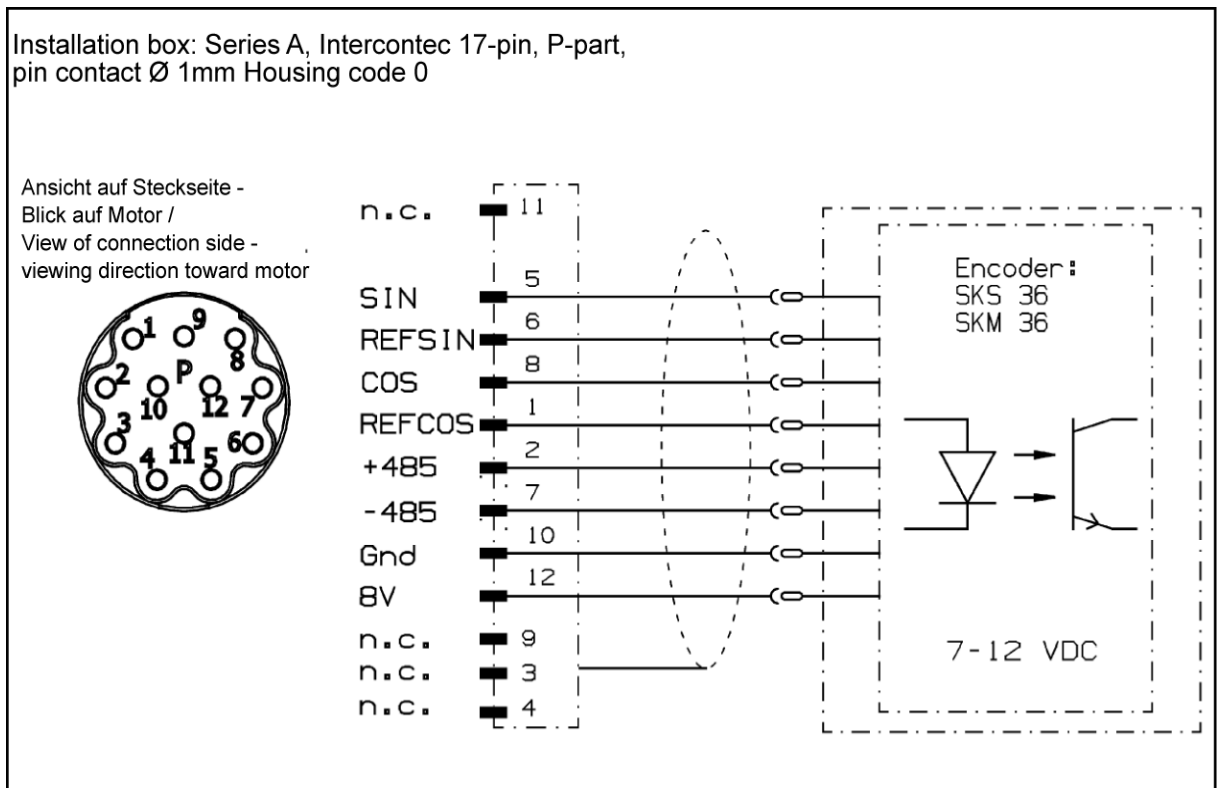

Option “R” —signal (pin assignment 4)

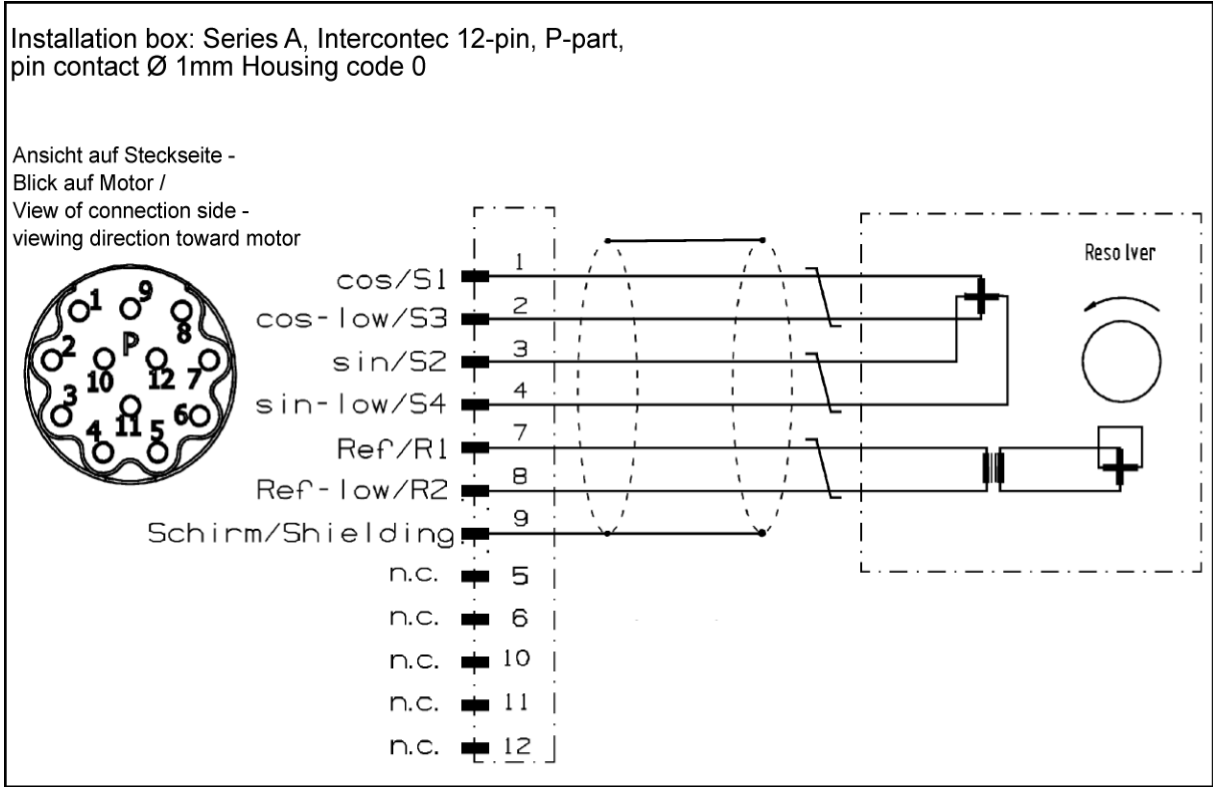

9.4.26 Pin assignment 5 TPM⁺ dynamic

Design with optical encoder —output (pin assignment 5)

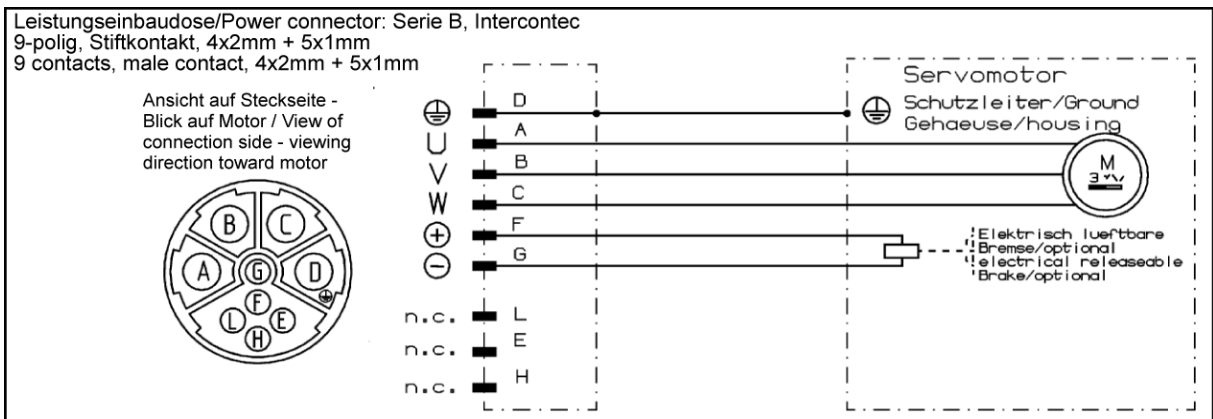

Option “E” and “V” with 320 V intermediate voltage —signal (pin assignment 5)

With TPM⁺ dynamic product size 004, 010 and 025 with 320V intermediate voltage

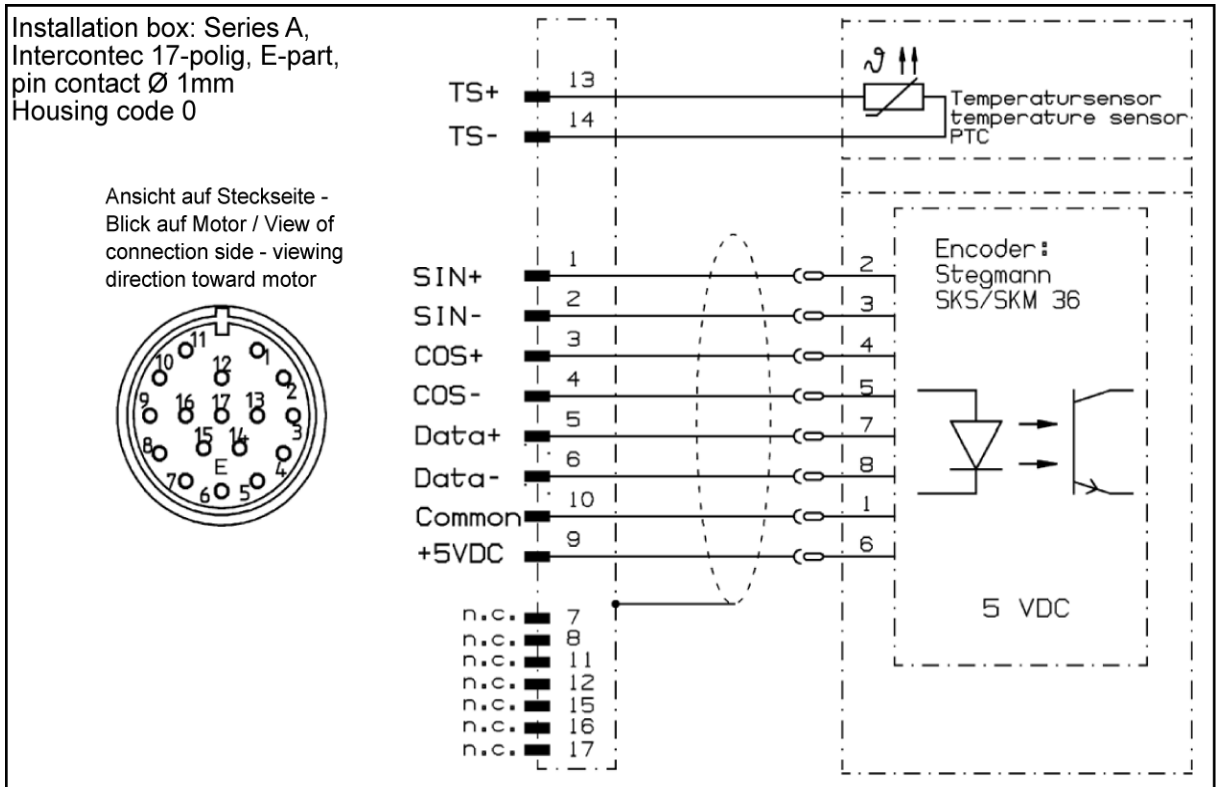

Option “E” and “V” with 560 V intermediate voltage —signal (pin assignment 5)

With TPM⁺ dynamic product size 050 with 320V and all product sizes with 560V intermediate voltages

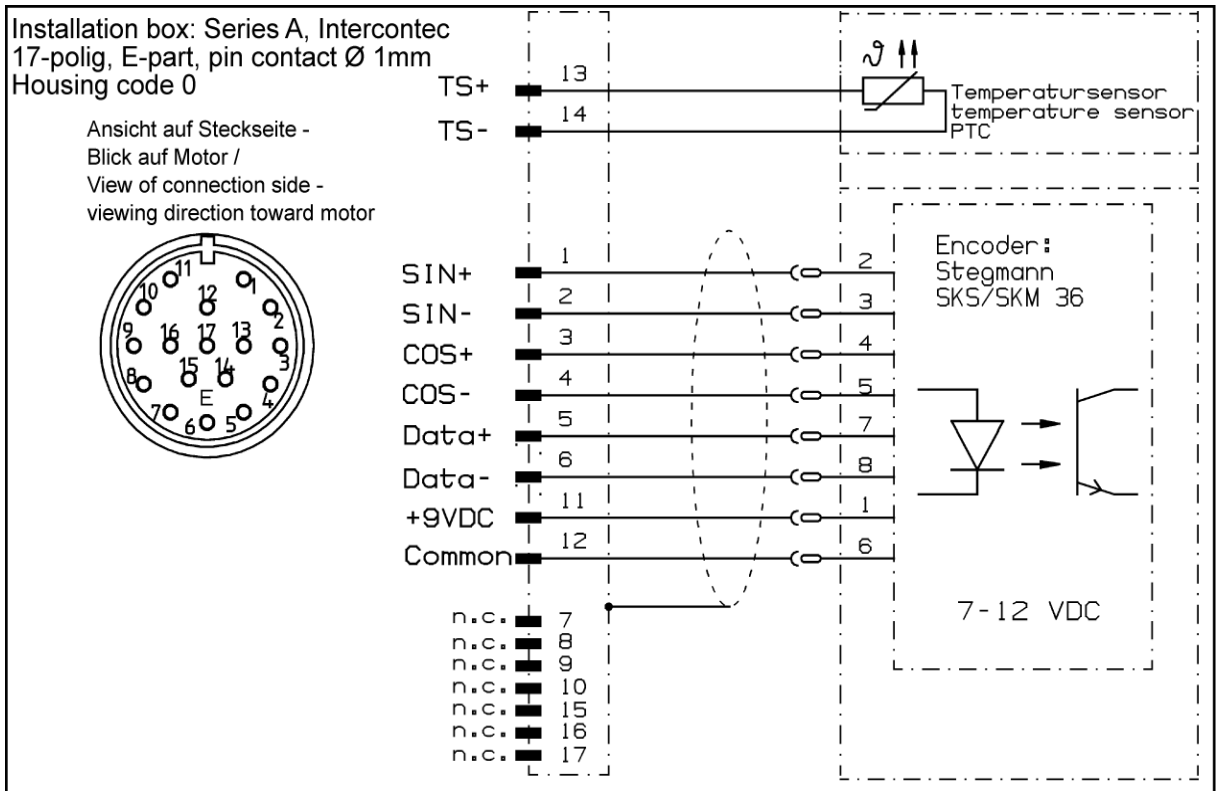

9.4.27 Pin assignment 6

Design with optical encoder — output (pin assignment 6)

Intercontec mounting socket, series production 923, 8-pin E, contact pin 4x2mm + 4x1mm		
View of plug side of actuator	Pin	Function
	1	U
	2 (⏏)	Earth conductor
	3	W
	4	V
	A	Temp +
	B	Temp -
	C	Brake + (optional)
	D	Brake - (optional)

Tbl-40: Design with optical encoder — output (pin assignment 6)

Option "S" and "M" — signal (pin assignment 6)

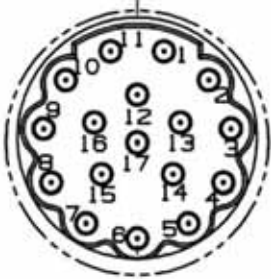
Intercontec mounting socket, series production 623, 17-pin E, contact pin Ø 1mm		
View of plug side of actuator	Pin	Function
	1	5V Sense
	2	n.c.
	3	n.c.
	4	0V Sense
	5	n.c.
	6	n.c.
	7	P-encoder / +5V
	8	clock
	9	*clock
	10	M-encoder / 0V
	11	n.c.
	12	Ua2
	13	*Ua2
	14	data
	15	Ua1
	16	*Ua1
	17	*data

Tbl-41: Option "S" and "M" — signal (pin assignment 6)

9.4.28 Cable setup / Cable cross-section

For ambient temperatures up to +30 °C, the following applies for cables acc. to DIN EN 60204:

Continuous stall current	Cable
0 –15 Aeff	4 x 1.5 mm ² & 2 x 0.75 mm ²
15 –21 Aeff	4 x 2.5 mm ² & 2 x 1 mm ²
21 –36 Aeff	4 x 6 mm ² & 2 x 1.5 mm ²
36 –50 Aeff	4 x 10 mm ² & 2 x 1.5 mm ²
50 –66 Aeff	4 x 16 mm ² & 2 x 1.5 mm ²

Tbl-42: Cable setup / Cable cross-section



WITTENSTEIN alpha GmbH · Walter-Wittenstein-Straße 1 · 97999 Igersheim · Germany
Tel. +49 7931 493-12900 · info@wittenstein.de

WITTENSTEIN - one with the future

www.wittenstein-alpha.de