

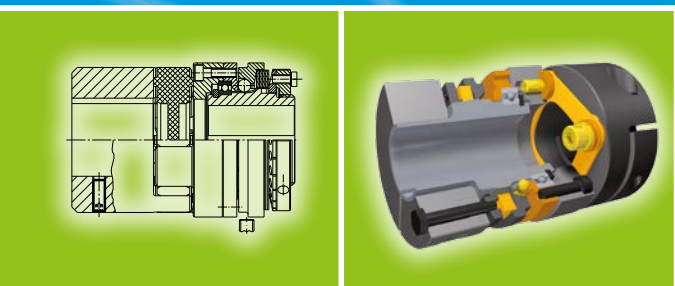

your reliable partner

EAS[®]-smartic[®]

Installation space-optimised
torque limiting clutches



Characteristics and Advantages of the EAS[®]-smartic[®]:

- ❑ **Very easy and quick installation via the clamping ring hub by tightening one single screw**
- ❑ **Durable backlash-free torque transmission**
- ❑ **Good dynamic characteristics**
- ❑ **Economical and reliable**
- ❑ **Simple and safe torque adjustment via a graduation scale with a directly readable torque indication**
- ❑ **Highest possible transmission security due to keyway and clamping ring hub**
- ❑ **High torque range from 6 – 100 % of the maximum torque**
- ❑ **Adjustment of the different torques possible by re-layering the cup springs already installed without reducing/adding the number of springs**



Function

The EAS[®]-smartic[®] Type 481 transmits the torque from the drive shaft onto a drive element which can be mounted onto the ball bearing-supported clutch flange.

The EAS[®]-smartic[®] Type 484 and Type 486 connect two shafts and compensate for shaft misalignments. The torque transmission takes place backlash-free for the entire lifetime of the clutch.

If the set limit torque is exceeded, the clutch disengages. The torque drops immediately. The mounted mayr[®]-limit switch registers the disengagement movement and switches off the drive. After the malfunction has been removed, the clutch re-engages automatically.

Re-engagement

After the malfunction (overload) has been removed, the clutch re-engages exactly at the point at which it previously disengaged. The input and output, therefore, always have the same angular position to each other during operation.

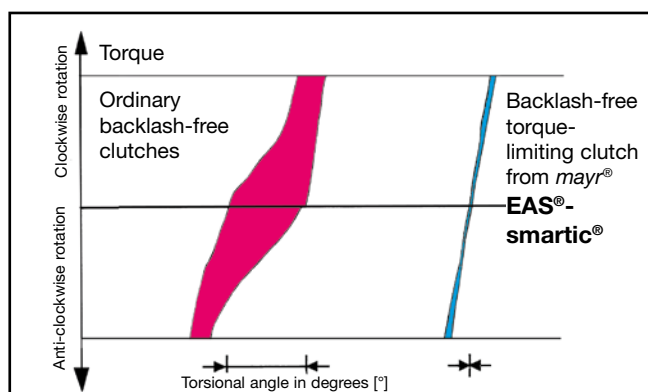

Backlash means:

- The torsional angle between the input and output of the clutch
- Also known as "torsional backlash"
- Not to be confused with the transmission backlash from the shaft onto the hub
- At mayr[®], backlash-free means: Backlash → 0 (see Diagram)

Torque Adjustment

If the torque is not specified on order, we set your clutch to approx. 80 % of the maximum torque. The reference marking and the torque indication show the set value directly.

Should the torque need setting to a different value, simply:

- Loosen the locking screw,
- Turn the adjusting nut using a hook wrench until the reference marking shows the required torque value.
- If necessary, slightly correct the adjusting nut position until the marking notches align, and
- Screw the locking screw back in again.

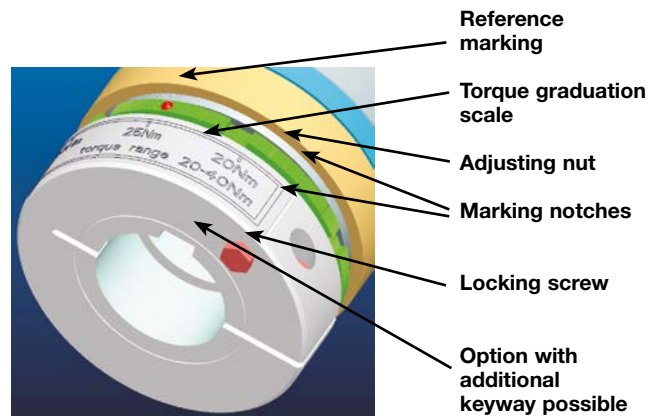

Installation

Shaft securement – clamping ring hub

The device is secured onto the shaft by tightening one single screw. The clamping ring hub is dimensioned so that it transfers even the maximum clutch torque safely and reliably. It is optionally available with an additional keyway for highest transmission safety.

Drive elements

Drive elements are centred on the ball bearing of the EAS[®]-smartic[®] and screwed together with the pressure flange.

The screw quality and the tightening torque on the fixing screws are to be chosen so that the set limit torque is transmitted with sufficient security using frictional locking.

EAS[®]-smartic[®] synchronous clutch

Summary of Constructional Design

EAS[®]-smartic[®] flange design

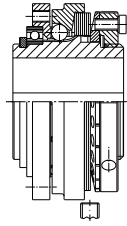

Fig. 1 Type 481._25.0

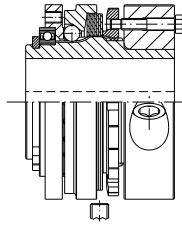

Fig. 2 Type 481._35.0 / 481._45.0

EAS[®]-smartic[®] flange clutch for backlash-free torque transmission between the shaft and the output element.

With key hub:	Type 481._25.0	pages 4/5
With clamping ring hub:	Type 481._35.0	pages 4/5
With clamping ring hub and keyway:	Type 481._45.0	pages 4/5

EAS[®]-smartic[®] lastic backlash-free

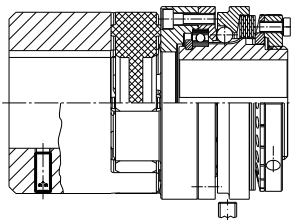

Fig. 3 Type 484._25._

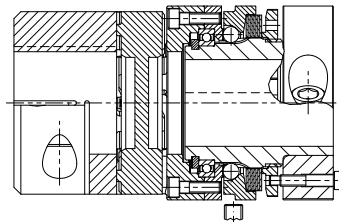

Fig. 4 Type 484._35._ / 484._45._

Overload clutch for backlash-free torque transmission between two coaxial shafts. Compensation of axial, radial and angular misalignments. High damping characteristics.

Key hub on both sides:	Type 484._25._	pages 6/7
Clamping (ring) hub on both sides:	Type 484._35._	pages 6/7
Clamping (ring) hub and keyway on both sides:	Type 484._45._	pages 6/7

EAS[®]-smartic[®] torsionally rigid

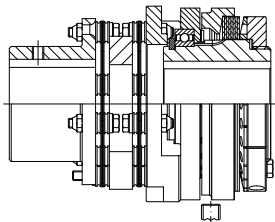

Fig. 5 Type 486._25.0

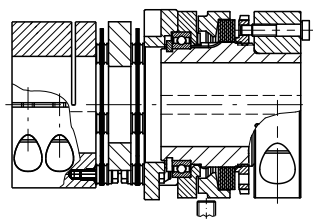

Fig. 6 Type 486._35.0 / 486._45.0

Overload clutch for backlash-free and torsionally rigid torque transmission between two coaxial shafts. Compensation of axial, radial and angular misalignments. High torsional spring rigidity.

Key hub on both sides:	Type 486._25.0	pages 8/9
Clamping (ring) hub on both sides:	Type 486._35.0	pages 8/9
Clamping (ring) hub and keyway on both sides:	Type 486._45.0	pages 8/9

Installation Examples

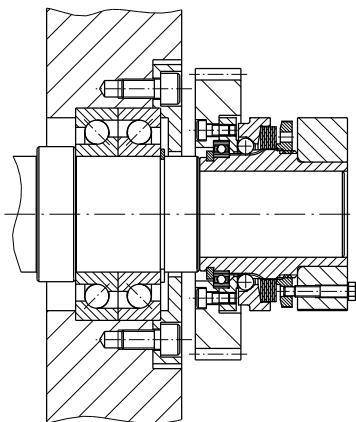

Fig. 7 Type 481._35.0

EAS[®]-smartic[®] flange clutch with clamping ring hub. The drive element is centred onto the deep groove ball bearing and screwed together with the pressure flange. If the resulting radial force lies anywhere near the centre of the ball bearing, an additional bearing on the drive element is unnecessary.

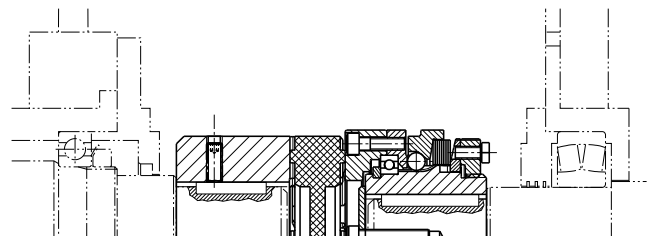

Fig. 8 Type 484._25._

EAS[®]-smartic[®] lastic backlash-free. Overload clutch with key hub on both sides for backlash-free torque transmission between two coaxial shafts. Compensation of axial, radial and angular misalignments. The axial securement takes place EAS[®]-side via a press cover or lastic-side via a set screw.

EAS®-smartic® synchronous clutch Type 481._.5.0

EAS®-smartic® flange design

Type 481._.35.0
with clamping ring hub

Type 481._.45.0
with clamping ring hub and keyway

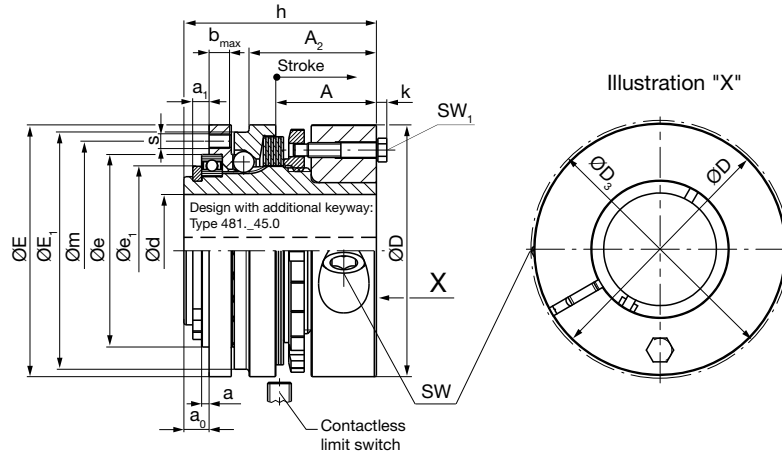

Dimensions	Size			
	01	0	1	2
a ¹⁾	2,5	2,5	2,5	3
a ₀	6,5	7,5	8,5	9
a ₁	4,5	5	5,5	6
A	29	29	34	38
A ₁	14	15	17	19
A ₂	33,5	37	43	50
A ₃	18,3	23	26	31
b _{max}	6	6,5	7	9,5
Ø D	55	70	85	100
Ø D ₂	50	65	78	91
Ø D ₃	59	72	88	104
Ø e _{h5}	42	52	65	78
Ø e ₁	39	50,5	61	72
Ø E	55	70	85	100
Ø E ₁	50	65	80	95
h	51	56	65	75
h ₁	36	42	48	56
k	2,8	2,8	3,5	4
k ₁	1,5	2,8	3,5	3,5
m	48	60	74	89
s	8 x M4	8 x M4	8 x M5	8 x M6
SW	6	6	8	10
SW ₁	7	7	8	10
SW ₃	5	7	8	8

Bores	Size	Size			
		01	0	1	2
Type 481._.25.0 Ø d ₂ ^{H7}	min.	10	14	19	20
	max.	22 ³⁾	30 ⁴⁾	38 ⁵⁾	45 ⁶⁾
Type 481._.35.0 Ø d ^{H7}	min. ²⁾	10	14	19	20
	max. ²⁾	22	32	42	50
Type 481._.45.0 Ø d ^{H7}	min.	10	14	19	20
	max.	20 ⁷⁾	30 ⁴⁾	38 ⁵⁾	45 ⁶⁾

We reserve the right to make dimensional and constructional alterations.

Accessory parts (hook wrench for torque adjustment)		
Size	Article number hook wrench	
	Type 481._.25.0	Types 481._.35.0 / 481._.45.0
01	8170662	8170663
0	4084939	4084158
1	4084939	4084158
2	4084940	4084159

- 1) Mounting tolerance +0,1.
- 2) The frictionally-locking transmittable torques are dependent on the bore diameter d, see Table below on page 6.
- 3) Up to ø 19 keyway acc. DIN 6885/1, over ø 19 keyway acc. DIN 6885/3
- 4) Up to ø 27 keyway acc. DIN 6885/1, over ø 27 keyway acc. DIN 6885/3
- 5) Up to ø 36 keyway acc. DIN 6885/1, over ø 36 keyway acc. DIN 6885/3
- 6) Up to ø 43 keyway acc. DIN 6885/1, over ø 43 keyway acc. DIN 6885/3
- 7) Up to ø 17 keyway acc. DIN 6885/1, over ø 17 keyway acc. DIN 6885/3



According to German notation, decimal points in this catalogue are represented with a comma (e.g. 0,5 instead of 0.5).

EAS[®]-smartic[®] synchronous clutch Type 481._.5.0

EAS[®]-smartic[®] flange design

Type 481._.25.0
with key hub

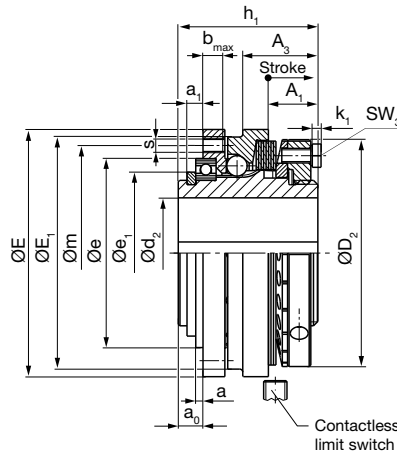

Technical Data				Size				
				01	0	1	2	
Limit torques for overload	Type 481.2_5.0 (Torque range 2)	M_G	[Nm]	2,7 – 5	5 – 10	10 – 20	20 – 40	
	Type 481.3_5.0 (Torque range 3)	M_G	[Nm]	5 – 10	10 – 20	20 – 40	40 – 80	
	Type 481.4_5.0 (Torque range 4)	M_G	[Nm]	8 – 15	15 – 30	30 – 60	60 – 120	
	Type 481.5_5.0 (Torque range 5)	M_G	[Nm]	11 – 20	20 – 40	40 – 80	80 – 160	
	Type 481.6_5.0 (Torque range 6)	M_G	[Nm]	18 – 33	35 – 65	70 – 125	140 – 250	
	Type 481.7_5.0 (Torque range 7)	M_G	[Nm]	32 – 40	60 – 80	120 – 160	240 – 320	
	Type 481.8_5.0 ⁹⁾ (Torque range 8)	M_G	[Nm]	35 – 60	70 – 120	150 – 240	300 – 500	
Maximum speed		n_{max}	[rpm]	3000	3000	2500	2000	
Thrust washer stroke on overload			[mm]	0,9	1,1	1,3	1,5	
Tightening torques, clamping screws	SW	T_A	[Nm]	40	40	83	140	
Mass moments of inertia ⁸⁾	Type 481._.25.0	EAS [®] -smartic [®] hub-side	J	[kgm ²]	0,00011	0,00037	0,00090	0,00220
		Output-side	J	[kgm ²]	0,00004	0,00012	0,00025	0,00060
	Type 481._.35.0	EAS [®] -smartic [®] hub-side	J	[kgm ²]	0,00021	0,00061	0,00177	0,00350
		Output-side	J	[kgm ²]	0,00004	0,00012	0,00025	0,00060
Weights ⁸⁾	Type 481._.25.0		[kg]	0,37	0,71	1,14	1,92	
	Type 481._.35.0		[kg]	0,60	1,00	1,62	2,62	
Permitted bearing load	Axial forces	F_A	[N]	400	500	800	1200	
	Radial forces	F_R	[N]	400	500	800	1200	
	Transverse force torques ¹⁰⁾	M_Q	[Nm]	3	5	10	15	

8) The mass moments of inertia and weights refer to clutches with maximum bore.

9) Maximum speed: 250 rpm

10) Torques which put strain on the deep groove ball bearing due to the non-centric axial forces having an effect the pressure flange.

Order Number

_ / 4 8 1 . _ _ 5 . 0 / _ / _ / _							
▲		▲		▲		▲	
Size	Torque range	2	2	Keyway	Bore	Bore	With limit switch
01	Torque range	3	3	Clamping ring hub	$\varnothing d^{H7}$	$\varnothing d_2^{H7}$	
0	Torque range	4	4	Clamping ring hub			
1	Torque range	5		+ keyway			see page 10
2	Torque range	6					
	Torque range	7					
	Torque range	8					

Example: 0 / 481.535.0 / 30 plus limit switch 055.002.5

EAS®-smartic® synchronous clutch Type 484._.5._

EAS®-smartic® lastic backlash-free

Type 484._.35._
Clamping (ring) hub on both sides

Type 484._.45._
Clamping (ring) hub and keyway
on both sides

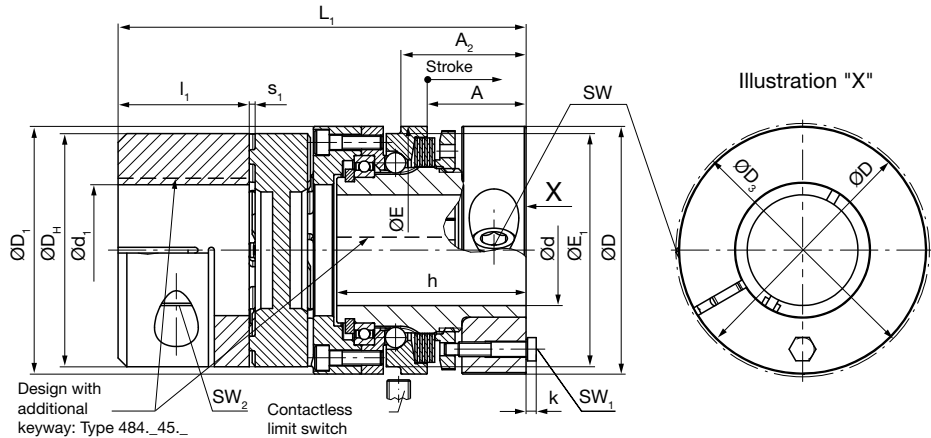

Dimensions	Size			
	01	0	1	2
A	29	29	34	38
A ₁	14	15	17	19
Ø D	55	70	85	100
Ø D ₁	57	70	85	105
Ø D ₂	50	65	78	91
Ø D _H	55	65	80	105
Ø E	55	70	85	100
Ø E ₁	50	65	80	95
G	M5	M6	M8	M8
h	51	56	65	75
h ₁	36	42	48	56
k	2,8	2,8	3,5	4
k ₁	1,5	2,8	3,5	3,5
L ₁	107	118	142	170
L ₂	92	104	125	151
l ₁	30	35	45	56
s ₁	2	2,5	3	3,5
SW	6	6	8	10
SW ₁	7	7	8	10
SW ₂	5	6	6	10
SW ₃	5	7	8	8
t	10	15	15	25

- 1) Up to ø 19 keyway acc. DIN 6885/1, over ø 19 keyway acc. DIN 6885/3
- 2) Up to ø 27 keyway acc. DIN 6885/1, over ø 27 keyway acc. DIN 6885/3
- 3) Up to ø 36 keyway acc. DIN 6885/1, over ø 36 keyway acc. DIN 6885/3

	Bores	Size	Size			
			01	0	1	2
EAS-smartic® side	Type 484._.25._	Ø d ₂ H7 min.	10	14	19	20
		max.	22 ¹⁾	30 ²⁾	38 ³⁾	45 ⁴⁾
	Type 484._.35._	Ø d H7 min.	10	14	19	20
		max.	22	32	42	50
ROBA-ES side	Type 484._.45._	Ø d H7 min.	10	14	19	20
		max.	20 ⁵⁾	30 ²⁾	38 ³⁾	45 ⁴⁾
	Type 484._.25._	Ø d ₃ H7 min.	8	10	13	20
		max.	28	38	45	60
	Type 484._.35._/4	Ø d ₁ F7 min. ⁶⁾	15	19	20	35
		max. ⁶⁾	28	35	45	55

We reserve the right to make dimensional and constructional alterations.

Accessory parts (hook wrench for torque adjustment)		
Size	Article number hook wrench	
	Type 484._.25._	Types 484._.35._ / 484._.45._
01	8170662	8170663
0	4084939	4084158
1	4084939	4084158
2	4084940	4084159

- 4) Up to ø 43 keyway acc. DIN 6885/1, over ø 43 keyway acc. DIN 6885/3
- 5) Up to ø 17 keyway acc. DIN 6885/1, over ø 17 keyway acc. DIN 6885/3
- 6) The transmittable torques on the flexible coupling "T_{KN}" are dependent on factors such as e.g. temperature factor, torsional rigidity factor etc., (please contact the manufacturers). Furthermore, the transmittable torques on the flexible coupling are dependent on the bore diameters d or d₁ (see Table below: Preferred bores and respective transmittable torques).

Preferred bores and respective transmittable torques [Nm] on diameters d and d ₁ of the hub frictional locking														
• for shaft tolerance k ₆ ROBA-ES-side														
• for shaft tolerance h ₆ EAS-smartic®-side														
Size	Ø 10	Ø 11	Ø 12	Ø 14	Ø 15	Ø 20	Ø 25	Ø 28	Ø 32	Ø 35	Ø 42	Ø 45	Ø 50	Ø 55
	Ø d	Ø d	Ø d	Ø d	Ø d	Ø d ₁	Ø d	Ø d ₁	Ø d	Ø d ₁	Ø d	Ø d ₁	Ø d	Ø d ₁
Torque ranges 2 up to 7 (Types 484.235._, 484.335._, 484.435._, 484.535._, 484.635._ and 484.735._)														
01	23	27	30	37	40	34	53	54	-	57	-	63	-	-
0	-	-	-	42	45	-	64	83	80	104	90	116	102	133
1	-	-	-	-	-	-	88	83	110	104	124	116	142	133
2	-	-	-	-	-	-	140	-	175	-	210	-	240	266
Torque range 8 (Type 484.835._)														
01	37	43	48	59	64	54	85	86	-	91	-	101	-	-
0	-	-	-	67	72	-	102	133	128	166	144	186	163	213
1	-	-	-	-	-	-	141	133	176	166	198	186	227	213
2	-	-	-	-	-	-	224	-	280	-	336	-	384	426

EAS[®]-smartic[®] synchronous clutch Type 484._ _5._

EAS[®]-smartic[®] lastic backlash-free
 Type 484._ 25._
 Key hub on both sides

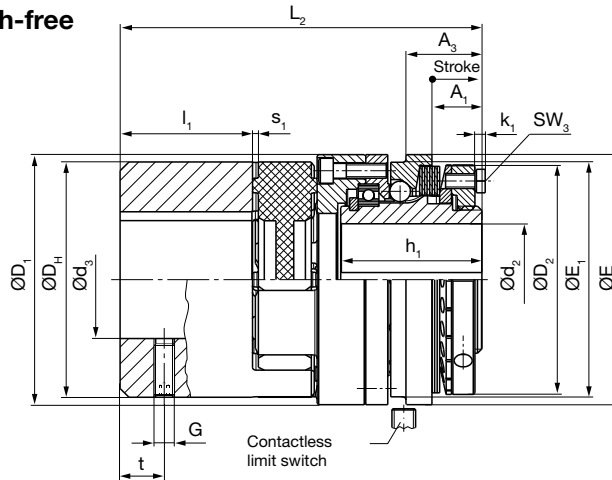

Technical Data				Size			
				01	0	1	2
Limit torques for overload	Type 484.2_5_ (Torque range 2)	M_G [Nm]	2,7 – 5	5 – 10	10 – 20	20 – 40	
	Type 484.3_5_ (Torque range 3)	M_G [Nm]	5 – 10	10 – 20	20 – 40	40 – 80	
	Type 484.4_5_ (Torque range 4)	M_G [Nm]	8 – 15	15 – 30	30 – 60	60 – 120	
	Type 484.5_5_ (Torque range 5)	M_G [Nm]	11 – 20	20 – 40	40 – 80	80 – 160	
	Type 484.6_5_ (Torque range 6)	M_G [Nm]	18 – 33	35 – 65	70 – 125	140 – 250	
	Type 484.7_5_ (Torque range 7)	M_G [Nm]	32 – 40	60 – 80	120 – 160	240 – 320	
	Type 481.8_5.0 ⁸⁾ (Torque range 8)	M_G [Nm]	35 – 60	70 – 120	150 – 240	300 – 500	
	Nominal and maximum torques, ⁶⁾ flexible backlash-free shaft coupling	92 Shore A	T_{KN} [Nm]	35	95	190	310
T_{Kmax} [Nm]			70	190	380	620	
Maximum speed	98 Shore A	T_{KN} [Nm]	60	160	325	525	
		T_{Kmax} [Nm]	120	320	650	1050	
Thrust washer stroke on overload		n_{max} [rpm]	3000	3000	2500	2000	
Tightening torques, clamping screws	SW	T_A [Nm]	40	40	83	140	
	SW ₂	Torque ranges 2 up to 7	T_A [Nm]	10	25	25	120
		Torque range 8	T_A [Nm]	17	40	40	140
Permitted misalignments, flexible backlash-free shaft coupling	Axial displacement	92/98 Shore A	ΔK_a [mm]	1,4	1,5	1,8	2,1
	Radial misalignment	92 Shore A	ΔK_r [mm]	0,14	0,15	0,17	0,21
		98 Shore A	ΔK_r [mm]	0,1	0,11	0,12	0,16
	Angular misalignment	92 Shore A	ΔK_w [°]	1,0	1,0	1,0	1,0
98 Shore A		ΔK_w [°]	0,9	0,9	0,9	0,9	
Mass moments of inertia ⁷⁾	Type 484._25_	EAS [®] -smartic [®] hub-side	J [kgm ²]	0,00011	0,00037	0,00090	0,00220
		ROBA [®] -ES-side	J [kgm ²]	0,00028	0,00056	0,00149	0,00773
	Type 484._35_	EAS [®] -smartic [®] hub-side	J [kgm ²]	0,00021	0,00061	0,00177	0,00350
		ROBA [®] -ES-side	J [kgm ²]	0,00024	0,00058	0,00140	0,00490
Weights ⁷⁾	Type 484._25_	Torque ranges 2 up to 7	[kg]	0,78	1,31	2,27	5,89
		Torque range 8	[kg]	1,01	1,62	2,75	6,72
Weights ⁷⁾	Type 484._35_	Torque ranges 2 up to 7	[kg]	1,29	2,06	3,59	6,72
		Torque range 8	[kg]	1,29	2,06	3,59	6,72

7) The mass moments of inertia and weights refer to clutches with maximum bore.

8) Maximum speed: 250 rpm

Order Number

_ / 4 8 4 . _ _ 5 . _ / _ / _ / _ / _ / _									
▲ ▲ ▲ ▲ ▲ ▲ ▲ ▲ ▲ ▲									
Size	Torque range	2	92 Shore A	3	Bore	Bore	Bore	Bore	With
01	Torque range	3	98 Shore A	4	Ø d ^{H7}	Ø d ₁ ^{F7}	Ø d ₂ ^{H7}	Ø d ₃ ^{H7}	limit switch
0	Torque range	4							
1	Torque range	5	2	Keyway					
2	Torque range	6	3	Clamping (ring) hub					see page 10
	Torque range	7	4	Clamping (ring) hub					
	Torque range	8		+ keyway					

Example: 1 / 484.535.4 / 35 / 35 / plus limit switch 055.002.5

EAS®-smartic® synchronous clutch Type 486._.5.0

EAS®-smartic® torsionally rigid

Type 486._35.0: Clamping (ring) hub on both sides

Type 486._45.0: Clamping (ring) hub and keyway on both sides

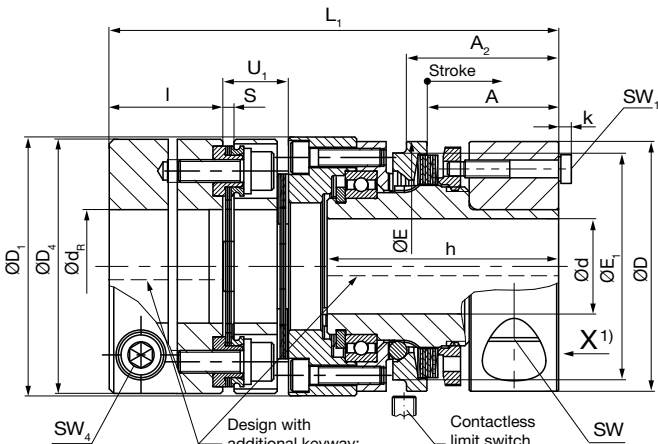

Sizes 01 to 1

Design with additional keyway:
Type 486._45.0

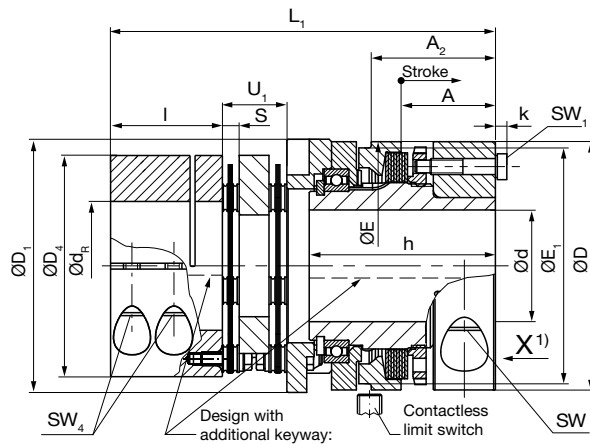

Size 2

Design with additional keyway:
Type 486._45.0

Dimensions	Size			
	01	0	1	2
A	29	29	34	38
A ₁	14	15	17	19
A ₂	33,5	37	43	50
A ₃	18,3	23	26	31
Ø d ₁	-	-	-	60
Ø D	55	70	85	100
Ø D ₁	57	70	85	102
Ø D ₂	50	65	78	91
Ø D ₃	59	72	88	104
Ø D ₄	56	69	79	89
Ø D ₅	-	-	-	89
Ø E	55	70	85	100
Ø E ₁	50	65	80	95
G	-	-	-	M6 ²⁾
h	51	56	65	75
h ₁	36	42	48	56
k	2,8	2,8	3,5	4
k ₁	1,5	2,8	3,5	3,5
L ₁	99,2	110,5	127,2	155,4
L ₂	84,2	96,5	110,2	136,4
l	25	32	33,5	45
S	2,6	3	2,9	7,2
SW	6	6	8	10
SW ₁	7	7	8	10
SW ₃	5	7	8	8
SW ₄	5	6	6	6
t	-	-	-	15
U ₁	14,7	15,5	15,8	26,4

	Bore	Size	Size			
			01	0	1	2
EAS-smartic® side	Type 486._25.0	Ø d ₂ H7 min.	10	14	19	20
		max.	22 ³⁾	30 ⁴⁾	38 ⁵⁾	45 ⁶⁾
	Type 486._35.0	Ø d H7 min.	10	14	19	20
		max.	22	32	42	50
ROBA®-DS side	Type 486._25.0	Ø d _p H7 min.	14	19	25	20
		max.	28	35	42	40
	Type 486._35.0	min. ^{8) 9)}	14	19	25	22
		max. ^{8) 9)}	28	35	42	52

We reserve the right to make dimensional and constructional alterations.

Accessory parts (hook wrench for torque adjustment)		
Size	Article number hook wrench	
	Type 486._25.0	Types 486._35.0 / 486._45.0
01	8170662	8170663
0	4084939	4084158
1	4084939	4084158
2	4084940	4084159

- 1) Illustration "X": see Fig. page 4.
- 2) M5 on bore under ø 22.
- 3) Up to ø 19 keyway acc. DIN 6885/1, over ø 19 keyway acc. DIN 6885/3
- 4) Up to ø 27 keyway acc. DIN 6885/1, over ø 27 keyway acc. DIN 6885/3
- 5) Up to ø 36 keyway acc. DIN 6885/1, over ø 36 keyway acc. DIN 6885/3
- 6) Up to ø 43 keyway acc. DIN 6885/1, over ø 43 keyway acc. DIN 6885/3
- 7) Up to ø 17 keyway acc. DIN 6885/1, over ø 17 keyway acc. DIN 6885/3
- 8) Type 486._35.0: The transmittable torques on the flexible torsionally rigid coupling are dependent on the bore diameters d or d_r (see Table below: Preferred bores and respective transmittable torques).
- 9) Recommended hubs/shaft tolerance, Type 486._35.0 – ROBA®-DS-side: H7 / k6 (Sizes 01 to 1) and H7 / h6 (Size 2).

Preferred bores and respective transmittable torques [Nm] on diameters d and d_r of the hub frictional locking

• for shaft tolerance k₆ (clamping hub Sizes 01 to 1) / h₆ (clamping hub Size 2) ROBA®-DS-side

• for shaft tolerance h₆ EAS-smartic®-side

Size	Ø 10	Ø 11	Ø 12	Ø 14	Ø 15	Ø 16	Ø 18	Ø 19	Ø 20	Ø 22	Ø 24	Ø 25	Ø 28	Ø 30	Ø 32	Ø 35	Ø 38	Ø 40	Ø 42	Ø 45	Ø 50	
	Ø d	Ø d	Ø d	Ø d	Ø d _R	Ø d	Ø d _R	Ø d _R	Ø d _R	Ø d	Ø d _R	Ø d _R	Ø d	Ø d _R	Ø d _R	Ø d	Ø d _R	Ø d _R	Ø d	Ø d _R	Ø d	Ø d
01	23	27	30	37	46	40	51	56	65	70	53	74	84	92	-	95	-	107	-	-	-	-
0	-	-	-	42	-	45	-	-	-	99	64	105	116	128	80	135	90	151	162	102	173	-
1	-	-	-	-	-	-	-	-	-	88	-	-	-	110	143	124	163	177	142	191	155	211
2	-	-	-	-	-	-	-	-	-	140	-	199	-	175	226	210	253	290	240	325	266	355

EAS[®]-smartic[®] synchronous clutch Type 486._.5.0

EAS[®]-smartic[®] torsionally rigid
 Type 486._.25.0: Key hub on both sides

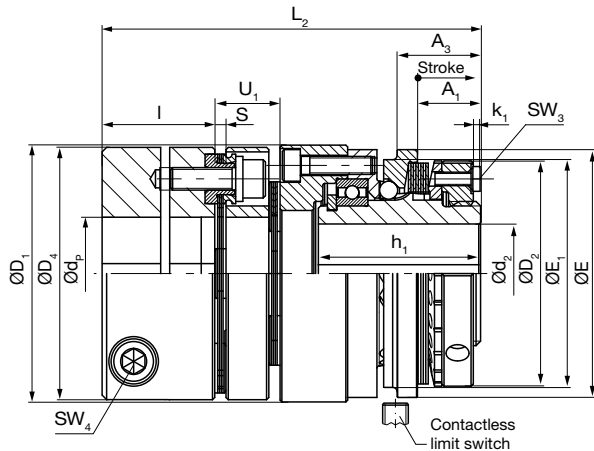

Sizes 01 to 1

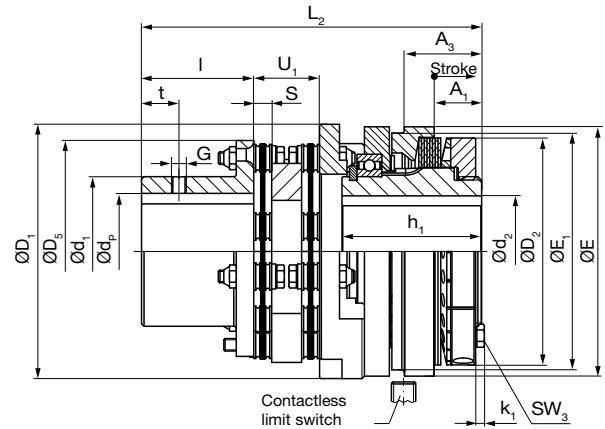

Size 2

Technical Data			Size				
			01	0	1	2	
Limit torques for overload	Type 486.2_5.0 (Torque range 2)	M_G [Nm]	2,7 – 5	5 – 10	10 – 20	20 – 40	
	Type 486.3_5.0 (Torque range 3)	M_G [Nm]	5 – 10	10 – 20	20 – 40	40 – 80	
	Type 486.4_5.0 (Torque range 4)	M_G [Nm]	8 – 15	15 – 30	30 – 60	60 – 120	
	Type 486.5_5.0 (Torque range 5)	M_G [Nm]	11 – 20	20 – 40	40 – 80	80 – 160	
	Type 486.6_5.0 (Torque range 6)	M_G [Nm]	18 – 33	35 – 65	70 – 125	140 – 250	
Nominal and peak torques, flexible torsionally rigid shaft coupling	Nominal torque ¹⁰⁾	T_{KN} [Nm]	60	100	150	290	
	Peak torque ¹¹⁾	T_{KS} [Nm]	90	150	225	435	
Maximum speed		n_{max} [rpm]	3000	3000	2500	2000	
Thrust washer stroke on overload		[mm]	0,9	1,1	1,3	1,5	
Tightening torques, clamping screws	SW	T_A [Nm]	40	40	83	140	
	SW ₄	T_A [Nm]	13	33	33	42	
Permitted misalignments ¹²⁾ flexible torsionally rigid shaft coupling	Axial displacement ¹³⁾	ΔK_a [mm]	0,7	0,9	1,1	1,3	
	Radial misalignment	ΔK_r [mm]	0,15	0,2	0,2	0,3	
	Angular misalignment	ΔK_w [°]	2,0	2,0	2,0	2,0	
Mass moments of inertia ¹⁴⁾	Type 486._.25.0	EAS [®] -smartic [®] hub-side	J [kgm ²]	0,00011	0,00037	0,00090	0,00220
		ROBA [®] -DS-side	J [kgm ²]	0,00027	0,00066	0,00138	0,00254
	Type 486._.35.0	EAS [®] -smartic [®] hub-side	J [kgm ²]	0,00021	0,00061	0,00177	0,00350
		ROBA [®] -DS-side	J [kgm ²]	0,00027	0,00066	0,00138	0,00352
Weights ¹⁴⁾	Type 486._.25.0	[kg]	0,84	1,43	2,22	3,60	
	Type 486._.35.0	[kg]	1,05	1,72	2,70	4,75	

10) Valid for max. permitted shaft misalignment.

11) Valid for unchanging load direction, max. load cycles $\leq 10^5$.

12) The permitted misalignments may not simultaneously reach their maximum value.

The values refer to couplings with 2 disk packs.

13) Only permitted as a static or virtually static value.

14) The mass moments of inertia and weights refer to clutches with maximum bore.

Order Number

_ / 4 8 6 . _ _ 5 . 0 / _ / _ / _ / _ / _									
▲ ▲ ▲ ▲ ▲ ▲ ▲ ▲ ▲ ▲									
Size	Torque range	2	2	Keyway	Bore	Bore	Bore	Bore	With limit switch
01	Torque range	3	3	Clamping (ring) hub	$\varnothing d^{H7}$	$\varnothing d_2^{H7}$	$\varnothing d_p^{H7}$	$\varnothing d_R^{H7}$	see page 10
0	Torque range	4	4	Clamping (ring) hub					
1	Torque range	5		+ keyway					
2	Torque range	6							
	Torque range	7							

Example: 1 / 486.535.0 / 35 / 35 / plus limit switch 055.002.5

EAS®-smartic® synchronous clutch

Limit Switch Installation

Adjust the switch distances for the contactless limit switch according to the Fig. below.
The distance of the thrust washer and the switching point can be finely adjusted using a hexagon head screw SW7.
On Size 2, use of the mechanical limit switch Type 055.000.5 is also possible.

Contactless limit switch

Undamped installation
(Limit switch is damped when clutch disengages)

Damped installation
(Limit switch is not damped when clutch disengages)

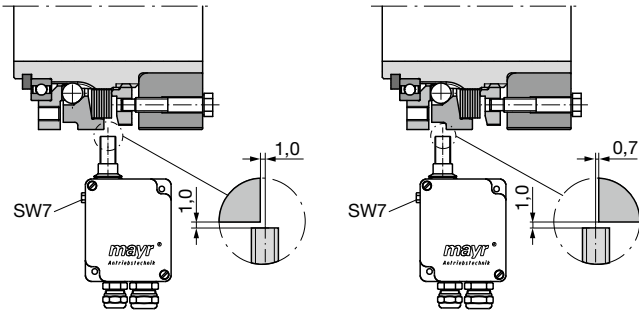

Limit switch Type 055.00_5 (contactless)

Technical Data

Input voltage (acc. design)	230 VAC, ±10 %, 50–60 Hz 115 VAC, ±10 %, 50–60 Hz 24 VDC, PELV, ±5 %, protected against reverse polarity, for overvoltage category II connection
Power consumption	Max. 1,5 VA
Ambient temperature	-10 °C up to +60 °C limit switch -25 °C up to +60 °C NAMUR-sensor
Protection	IP54
Conductor cross section	Max. 2,5 mm ² / AWG 14
Weight	400 g / 14 oz
Protection fuse	0,1 A/fast acting at 24 VDC (in system)
Signalling relay	Floating changeover contacts Contact load max. 250 VAC/12 A Contact material AgNi 90/10 Max. switching frequency 20 Hz at min. load, 0,1 Hz at max. load
NAMUR-Sensor internal	Installed in a light metal housing, switching distance S_n 2 mm, flush fitting, max. switching frequency 2 kHz, the zero point can be adjusted by 1 mm each using the side adjusting screw SW 7
NAMUR-Sensor external	Metal housing M12 x 1, switching distance S_n 2 mm, flush fitting, max. switching frequency 2 kHz, standard cable length 2 m, max. 100 m on special design, protection IP67

Order Number

0 5 5 . 0 0 _ . 5 / _



Contactless sensing		Connection voltage	
Sensor external	1	230 VAC	
Sensor internal	2	115 VAC	
		24 VDC	

Contactless limit switch with mounting flange

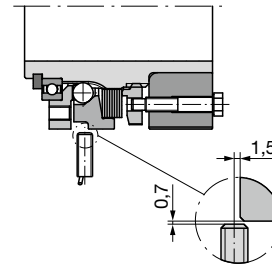

Limit switch Type 055.012.6 (contactless, with mounting flange)

Technical Data

Name	NBB1,5-8GM30-E2-Y
Construction size	M8 x 1
Construction type	Rustproof stainless steel
Input voltage	10 – 30 VDC PELV
No-load current	≤ 15 mA
Current carrying capacity	100 mA
Contact type	PNP NO contact
Switching distance S_n	1,5 mm, flush fitting
Assured switching distance S_a	1,2 mm
Characteristics	Reverse voltage protection Synchronised short-circuit protection Switching condition indication via LED
Connection type	Cable 3 m/PUR
Tightening torque	10 Nm
Conductor cross section	0,14 mm ²
Ambient temperature	-25 °C up to +70 °C
Protection	IP67
Accessory	Mounting flange

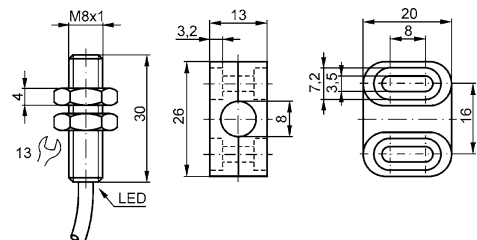

Order Number

0 5 5 . 0 1 2 . 6 / _



Connection voltage	10 – 30 VDC
--------------------	-------------

Product Summary

Safety Clutches/Overload Clutches

- ❑ **EAS®-Compact®/EAS®-NC**
Positive locking and completely backlash-free torque limiting clutches
- ❑ **EAS®-smartic®**
Cost-effective torque limiting clutches, quick installation
- ❑ **EAS®-element clutch/EAS®-elements**
Load-disconnecting protection against high torques
- ❑ **EAS®-axial**
Exact limitation of tensile and compressive forces
- ❑ **EAS®-Sp/EAS®-Sm/EAS®-Zr**
Load-disconnecting torque limiting clutches with switching function
- ❑ **ROBA®-slip hub**
Load-holding, frictionally locked torque limiting clutches
- ❑ **ROBA®-contitorque**
Magnetic continuous slip clutches

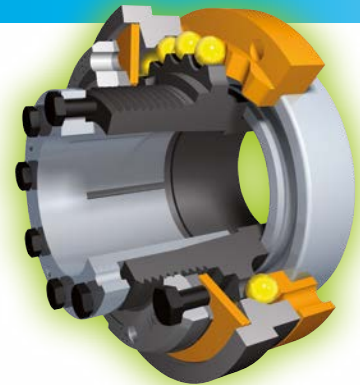

Shaft Couplings

- ❑ **smartflex®/primeflex®**
Perfect precision couplings for servo and stepping motors
- ❑ **ROBA®-ES**
Backlash-free and damping for vibration-sensitive drives
- ❑ **ROBA®-DS/ROBA®-D**
Backlash-free, torsionally rigid all-steel couplings
- ❑ **ROBA®-DSM**
Cost-effective torque-measuring couplings

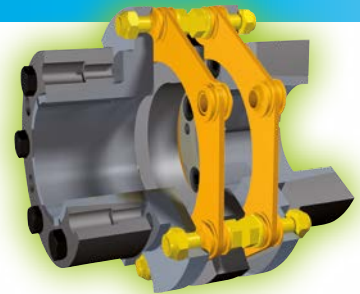

Electromagnetic Brakes/Clutches

- ❑ **ROBA-stop® standard**
Multifunctional all-round safety brakes
- ❑ **ROBA-stop®-M motor brakes**
Robust, cost-effective motor brakes
- ❑ **ROBA-stop®-S**
Water-proof, robust monoblock brakes
- ❑ **ROBA-stop®-Z/ROBA-stop®-silenzio®**
Doubly safe elevator brakes
- ❑ **ROBA®-diskstop®**
Compact, very quiet disk brakes
- ❑ **ROBA®-topstop®**
Brake systems for gravity loaded axes
- ❑ **ROBA®-linearstop**
Backlash-free brake systems for linear motor axes
- ❑ **ROBA®-guidestop**
Backlash-free holding brake for profield rail guides
- ❑ **ROBATIC®/ROBA®-quick/ROBA®-takt**
Electromagnetic clutches and brakes, clutch brake units



DC Drives

- ❑ **tendo®-PM**
Permanent magnet-excited DC motors
- ❑ **tendo®-SC**
1 quadrant and 4 quadrant transistor controllers

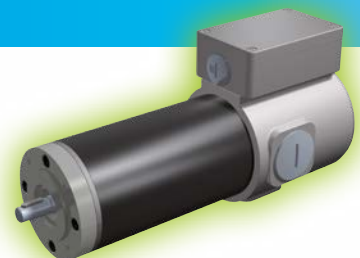



Headquarters

Chr. Mayr GmbH + Co. KG
Eichenstraße 1, D-87665 Mauerstetten
Tel.: +49 83 41/8 04-0, Fax: +49 83 41/80 44 21
www.mayr.com, E-Mail: info@mayr.com



your reliable partner

Service Germany

Baden-Württemberg

Esslinger Straße 7
 70771 Leinfelden-Echterdingen
 Tel.: 07 11/45 96 01 0
 Fax: 07 11/45 96 01 10

Bavaria

Eichenstraße 1
 87665 Mauerstetten
 Tel.: 0 83 41/80 41 04
 Fax: 0 83 41/80 44 23

Chemnitz

Bornaer Straße 205
 09114 Chemnitz
 Tel.: 03 71/4 74 18 96
 Fax: 03 71/4 74 18 95

Franken

Unterer Markt 9
 91217 Hersbruck
 Tel.: 0 91 51/81 48 64
 Fax: 0 91 51/81 62 45

Hagen

Im Langenstück 6
 58093 Hagen
 Tel.: 0 23 31/78 03 0
 Fax: 0 23 31/78 03 25

Kamen

Lünener Straße 211
 59174 Kamen
 Tel.: 0 23 07/23 63 85
 Fax: 0 23 07/24 26 74

North

Schiefer Brink 8
 32699 Extertal
 Tel.: 0 57 54/9 20 77
 Fax: 0 57 54/9 20 78

Rhine-Main

Hans-Böckler-Straße 6
 64823 Groß-Umstadt
 Tel.: 0 60 78/7 82 53 37
 Fax: 0 60 78/9 30 08 00

Branch office

China

Mayr Zhangjiagang
 Power Transmission Co., Ltd.
 Changxing Road No. 16,
 215600 Zhangjiagang
 Tel.: 05 12/58 91-75 65
 Fax: 05 12/58 91-75 66
 info@mayr-ptc.cn

Great Britain

Mayr Transmissions Ltd.
 Valley Road, Business Park
 Keighley, BD21 4LZ
 West Yorkshire
 Tel.: 0 15 35/66 39 00
 Fax: 0 15 35/66 32 61
 sales@mayr.co.uk

France

Mayr France S.A.S.
 Z.A.L. du Minopole
 Rue Nungesser et Coli
 62160 Bully-Les-Mines
 Tel.: 03.21.72.91.91
 Fax: 03.21.29.71.77
 contact@mayr.fr

Italy

Mayr Italia S.r.l.
 Viale Veneto, 3
 35020 Saonara (PD)
 Tel.: 0498/79 10 20
 Fax: 0498/79 10 22
 info@mayr-italia.it

Singapore

Mayr Transmission (S) PTE Ltd.
 No. 8 Boon Lay Way Unit 03-06,
 TradeHub 21
 Singapore 609964
 Tel.: 00 65/65 60 12 30
 Fax: 00 65/65 60 10 00
 info@mayr.com.sg

Switzerland

Mayr Kupplungen AG
 Tobelackerstraße 11
 8212 Neuhausen am Rheinfall
 Tel.: 0 52/6 74 08 70
 Fax: 0 52/6 74 08 75
 info@mayr.ch

USA

Mayr Corporation
 4 North Street
 Waldwick
 NJ 07463
 Tel.: 2 01/4 45-72 10
 Fax: 2 01/4 45-80 19
 info@mayrcorp.com

Representatives

Australia

Regal Beloit Australia Pty Ltd.
 19 Corporate Ave
 03178 Rowville, Victoria
 Australien
 Tel.: 0 3/92 37 40 00
 Fax: 0 3/92 37 40 80
 salesAUvic@regalbeloit.com

India

National Engineering
 Company (NENCO)
 J-225, M.I.D.C.
 Bhosari Pune 411026
 Tel.: 0 20/27 13 00 29
 Fax: 0 20/27 13 02 29
 nenco@nenco.org

Japan

MATSUI Corporation
 2-4-7 Azabudai
 Minato-ku
 Tokyo 106-8641
 Tel.: 03/35 86-41 41
 Fax: 03/32 24 24 10
 k.goto@matsui-corp.co.jp

Netherlands

Groneman BV
 Amarilstraat 11
 7554 TV Hengelo OV
 Tel.: 074/2 55 11 40
 Fax: 074/2 55 11 09
 aandrijftechnik@groneman.nl

Poland

Wamex Sp. z o.o.
 ul. Pozaryskiego, 28
 04-703 Warszawa
 Tel.: 0 22/6 15 90 80
 Fax: 0 22/8 15 61 80
 wamex@wamex.com.pl

South Korea

Mayr Korea Co. Ltd.
 Room No.1002, 10th floor,
 Nex Zone, SK TECHNOPARK,
 77-1, SungSan-Dong,
 SungSan-Gu, Changwon, Korea
 Tel.: 0 55/2 62-40 24
 Fax: 0 55/2 62-40 25
 info@mayrkorea.com

Taiwan

German Tech Auto Co., Ltd.
 No. 28, Fenggong Zhong Road,
 Shengang Dist.,
 Taichung City 429, Taiwan R.O.C.
 Tel.: 04/25 15 05 66
 Fax: 04/25 15 24 13
 abby@zfgta.com.tw

Czech Republic

BMC - TECH s.r.o.
 Hvězdoslavova 29 b
 62700 Brno
 Tel.: 05/45 22 60 47
 Fax: 05/45 22 60 48
 info@bmc-tech.cz

More representatives:

Austria, Belgium, Brazil, Canada, Denmark, Finland, Greece, Hongkong, Hungary, Indonesia, Israel, Luxembourg, Malaysia, New Zealand, Norway, Philippines, Romania, Russia, Slovakia, Slovenia, South Africa, Spain, Sweden, Thailand, Turkey

You can find the complete address for the representative responsible for your area under www.mayr.com in the internet.