

SK⁺ / SPK⁺ – Space-saving right-angle precision with output shaft



SK⁺

The versatile hypoid gearbox with SP⁺ compatible output shaft. SPK⁺ gearboxes with planetary stage are especially suitable for high-precision applications requiring higher power and outstanding torsional rigidity.

The SK⁺ / SPK⁺ compared to the industry standard

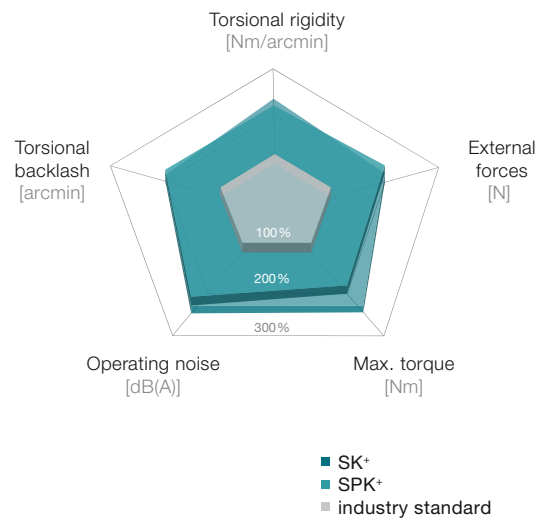

Product highlights

Max. torsional backlash
 SK⁺ ≤ 4 arcmin (Standard)
 SPK⁺ ≤ 4 arcmin (Standard)
 ≤ 2 arcmin (Reduced)

Diverse range of ratios $i = 3 - 10,000$

Flexibility thanks to various output types

Other gearbox models
 Corrosional resistant design, ATEX (SK⁺)



SPK⁺ in corrosion-resistant design



SK⁺ with rearward shaft

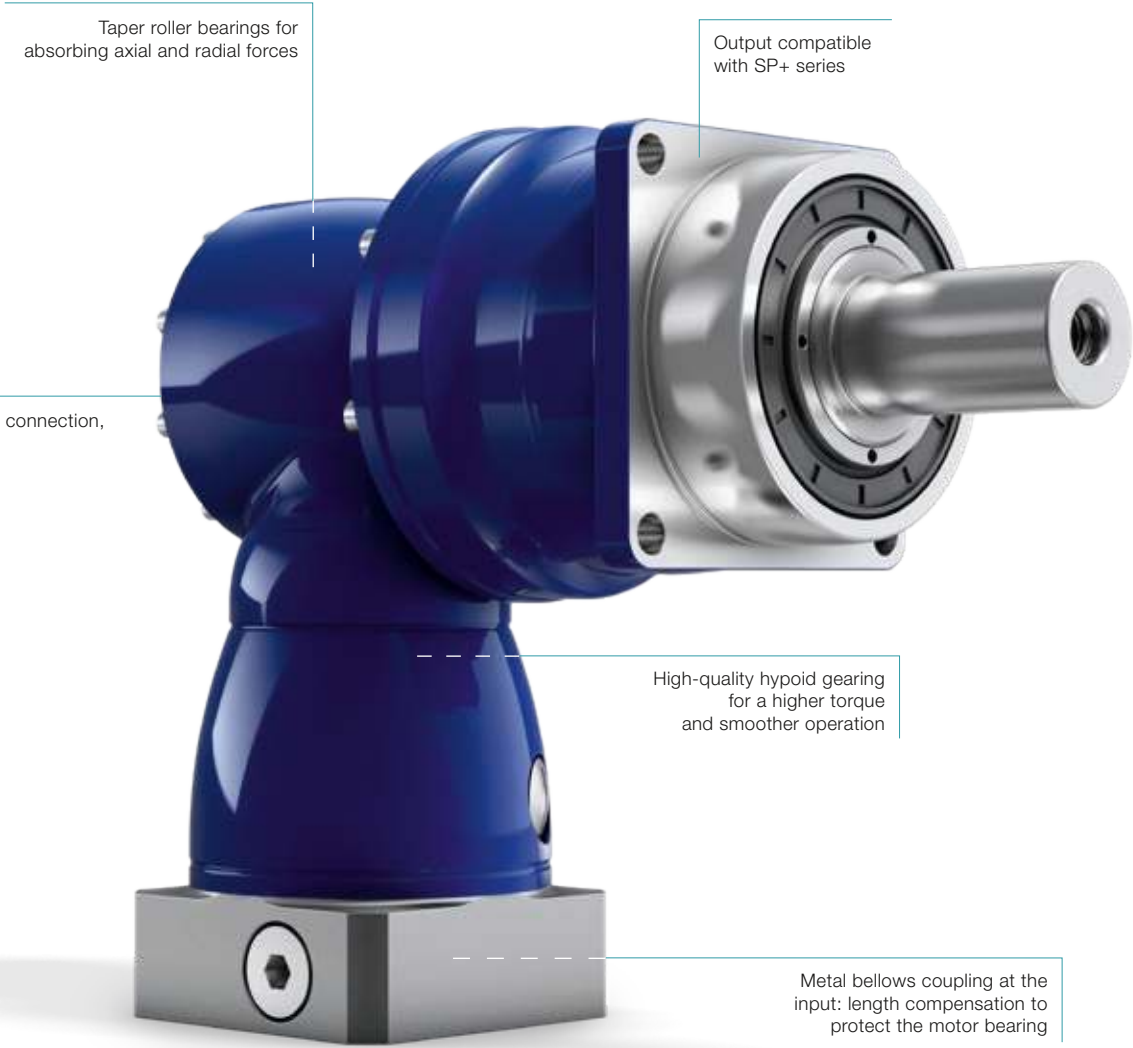

SPK+



SPK+ with rack and pinion



SK+ with metal bellows coupling

SK+ 060 MF 1-/2-stage

			1-stage					2-stage										
Ratio	<i>i</i>		3	4	5	7	10	12	16	20	25	28	35	40	50	70	100	
Max. torque ^{a) b) e)}	T_{2a}	Nm	36	36	36	25	20	36	36	36	36	36	36	36	36	25	20	
		in.lb	319	319	319	221	177	319	319	319	319	319	319	319	319	319	221	177
Max. acceleration torque ^{b) e)} (max. 1000 cycles per hour)	T_{2B}	Nm	30	30	30	25	20	30	30	30	30	30	30	30	30	25	20	
		in.lb	266	266	266	221	177	266	266	266	266	266	266	266	266	221	177	
Nominal torque (at n_n)	T_{2N}	Nm	22	22	22	20	15	22	22	22	22	22	22	22	22	20	15	
		in.lb	195	195	195	177	133	195	195	195	195	195	195	195	195	177	133	
Emergency stop torque ^{a) b) e)} (permitted 1000 times during the service life of the gearbox)	T_{2Not}	Nm	40	50	50	45	40	50	50	50	50	50	50	50	50	45	40	
		in.lb	354	443	443	398	354	443	443	443	443	443	443	443	443	398	354	
Permitted average input speed (at T_{2a} and 20 °C ambient temperature) ^{d)}	n_{1N}	n_{1T}	2500	2700	3000	3000	3000	4400	4400	4400	4400	4400	4400	4400	4800	5500	5500	
Max. input speed	n_{1Max}	rpm	7500	7500	7500	7500	7500	6000	6000	6000	6000	6000	6000	6000	6000	6000	6000	
Mean no load running torque ^{b)} (at $n_i = 3000$ rpm and 20 °C gearbox temperature)	T_{012}	Nm	1.2	1.1	1	1.2	1.1	0.2	0.2	0.2	0.2	0.2	0.2	0.2	0.1	0.1	0.1	
		in.lb	11	10	9	11	10	2	2	2	2	2	2	2	1	1	1	
Max. backlash	j_t	arcmin	Standard ≤ 5															
Torsional rigidity ^{b)}	C_{t21}	Nm/arcmin	2	2.1	2.2	2	1.8	2.1	2.1	2.1	2.1	2.1	2.1	2.1	2.2	2	1.8	
		in.lb/arcmin	18	19	19	18	16	19	19	19	19	19	19	19	19	18	16	
Max. axial force ^{c)}	F_{2AMax}	N	2400															
		lb _f	540															
Max. lateral force ^{c)}	F_{2QMax}	N	2700															
		lb _f	608															
Max. tilting moment	M_{2KMax}	Nm	251															
		in.lb	2222															
Efficiency at full load	η	%	96					94										
Service life	L_h	h	> 20000															
Weight (incl. standard adapter plate)	m	kg	2.9					3.2										
		lb _m	6					7										
Operating noise (at reference ratio and reference speed – ratio-specific values available in cymex [®])	L_{PA}	dB(A)	≤ 64															
Max. permitted housing temperature		°C	+90															
		F	194															
Ambient temperature		°C	0 to +40															
		F	32 to 104															
Lubrication			Lubricated for life															
Direction of rotation			In- and output opposite direction															
Protection class			IP 65															
Metal bellows coupling (recommended product type – validate sizing with cymex [®])			BC2 - 00030AA - 016.000 - X															
Bore diameter of coupling on the application side		mm	X = 010.000 - 030.000															
Mass moment of inertia (relates to the drive) Clamping hub diameter [mm]	B	11	J_i	kgcm ²	-	-	-	-	-	0.09	0.09	0.07	0.07	0.06	0.06	0.06	0.06	
				10 ⁻³ in.lb.s ²	-	-	-	-	-	0.08	0.08	0.06	0.06	0.05	0.05	0.05	0.05	0.05
	C	14	J_i	kgcm ²	0.52	0.44	0.4	0.36	0.34	0.2	0.2	0.19	0.19	0.18	0.18	0.17	0.17	0.17
				10 ⁻³ in.lb.s ²	0.46	0.39	0.35	0.32	0.3	0.18	0.18	0.17	0.17	0.16	0.16	0.15	0.15	0.15
	E	19	J_i	kgcm ²	0.87	0.79	0.75	0.71	0.7	-	-	-	-	-	-	-	-	-
				10 ⁻³ in.lb.s ²	0.77	0.7	0.66	0.63	0.62	-	-	-	-	-	-	-	-	-

Please use our sizing software cymex[®] for a detailed sizing – www.wittenstein-cymex.com
Please contact us for optimum sizing at S1 conditions (Continuous operation).

- ^{a)} At max. 10 % F_{2QMax}
- ^{b)} Valid for standard clamping hub diameter
- ^{c)} Refers to center of the output shaft or flange
- ^{d)} Please reduce input speed at higher ambient temperatures
- ^{e)} Smooth shaft

View A

1-stage

up to 14/19⁴⁾
(C⁵⁾/E) clamping
hub diameter

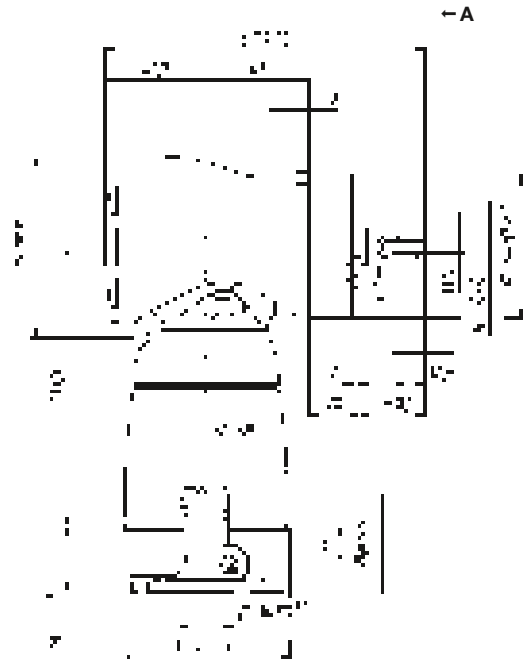

2-stage

up to 11/14⁴⁾
(B⁵⁾/C) clamping
hub diameter

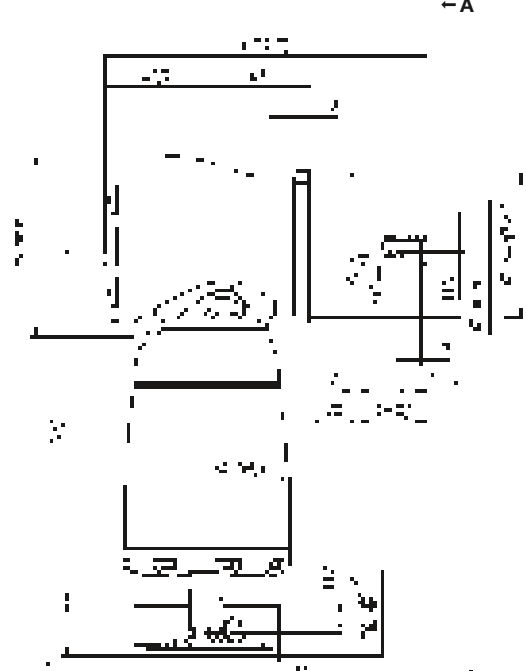
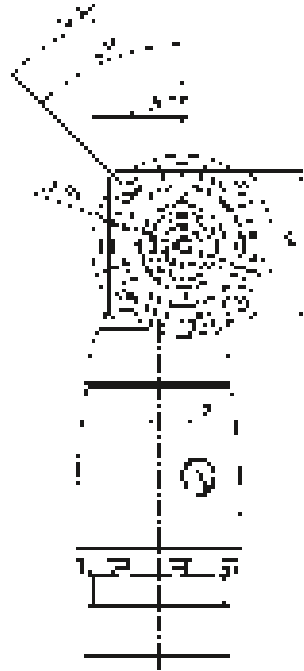

Motor shaft diameter [mm]

Hypoid gearboxes

SK*

Other output variants

Shaft with key

Splined shaft (DIN 5480)

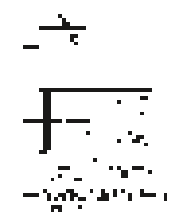
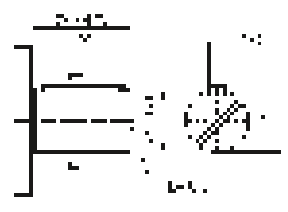

See technical data sheet for available clamping hub diameters (mass moment of inertia). Dimensions available on request.

- Non-tolerated dimensions are nominal dimensions
- ¹⁾ Check motor shaft fit
- ²⁾ Min./Max. permissible motor shaft length. Longer motor shafts are possible, please contact alpha.
- ³⁾ The dimensions depend on the motor
- ⁴⁾ Smaller motor shaft diameter is compensated by a bushing with a minimum thickness of 1 mm
- ⁵⁾ Standard clamping hub diameter

SK+ 075 MF 1-/2-stage

			1-stage					2-stage											
Ratio	<i>i</i>		3	4	5	7	10	12	16	20	25	28	35	40	50	70	100		
Max. torque ^{a) b) e)}	T_{2a}	Nm	84	84	84	60	50	84	84	84	84	84	84	84	84	60	50		
		in.lb	743	743	743	531	443	743	743	743	743	743	743	743	743	743	531	443	
Max. acceleration torque ^{b) e)} (max. 1000 cycles per hour)	T_{2B}	Nm	70	70	70	60	50	70	70	70	70	70	70	70	70	60	50		
		in.lb	620	620	620	531	443	620	620	620	620	620	620	620	620	620	531	443	
Nominal torque (at n_N)	T_{2N}	Nm	50	50	50	45	40	50	50	50	50	50	50	50	50	45	40		
		in.lb	443	443	443	398	354	443	443	443	443	443	443	443	443	443	398	354	
Emergency stop torque ^{a) b) e)} (permitted 1000 times during the service life of the gearbox)	T_{2Not}	Nm	95	115	115	110	100	115	115	115	115	115	115	115	115	110	100		
		in.lb	841	1018	1018	974	885	1018	1018	1018	1018	1018	1018	1018	1018	1018	974	885	
Permitted average input speed (at T_{2a} and 20 °C ambient temperature) ^{d)}	n_{1N}	n_{1T}	2300	2500	2800	2800	2800	3500	3500	3500	3500	3500	3500	3500	3800	4500	4500		
Max. input speed	n_{1Max}	rpm	7500	7500	7500	7500	7500	6000	6000	6000	6000	6000	6000	6000	6000	6000	6000		
Mean no load running torque ^{b)} (at $n_1 = 3000$ rpm and 20 °C gearbox temperature)	T_{012}	Nm	2	1.7	1.5	2	1.8	0.3	0.3	0.2	0.2	0.2	0.2	0.1	0.1	0.1	0.1		
		in.lb	18	15	13	18	16	3	3	2	2	2	2	1	1	1	1		
Max. backlash	j_t	arcmin	Standard ≤ 4																
Torsional rigidity ^{b)}	C_{t21}	Nm/arcmin	5	5.5	6	6	6	5.5	5.5	5.5	5.5	5.5	5.5	5.5	6	6	6		
		in.lb/arcmin	44	49	53	53	53	49	49	49	49	49	49	49	53	53	53		
Max. axial force ^{c)}	F_{2AMax}	N	3400																
		lb _f	765																
Max. lateral force ^{c)}	F_{2QMax}	N	4000																
		lb _f	900																
Max. tilting moment	M_{2KMax}	Nm	437																
		in.lb	3868																
Efficiency at full load	η	%	96					94											
Service life	L_h	h	> 20000																
Weight (incl. standard adapter plate)	m	kg	4.8					5.4											
		lb _m	11					12											
Operating noise (at reference ratio and reference speed – ratio-specific values available in cymex [®])	L_{PA}	dB(A)	≤ 66																
Max. permitted housing temperature		°C	+90																
		F	194																
Ambient temperature		°C	0 to +40																
		F	32 to 104																
Lubrication			Lubricated for life																
Direction of rotation			In- and output opposite direction																
Protection class			IP 65																
Metal bellows coupling (recommended product type – validate sizing with cymex [®])			BC2 - 00080AA - 022.000 - X																
Bore diameter of coupling on the application side		mm	X = 014.000 - 042.000																
Mass moment of inertia (relates to the drive) Clamping hub diameter [mm]	C	14	J_1	kgcm ²	-	-	-	-	-	0.28	0.27	0.23	0.23	0.2	0.2	0.18	0.18	0.18	
				10 ⁻³ in.lb.s ²	-	-	-	-	-	0.25	0.24	0.2	0.2	0.18	0.18	0.16	0.16	0.16	0.16
	E	19	J_1	kgcm ²	1.46	1.19	1.06	0.95	0.9	0.73	0.71	0.68	0.67	0.63	0.62	0.63	0.63	0.63	0.63
				10 ⁻³ in.lb.s ²	1.29	1.05	0.94	0.84	0.8	0.65	0.63	0.6	0.59	0.56	0.55	0.56	0.56	0.56	0.56
H	28	J_1	kgcm ²	2.88	2.61	2.47	2.37	2.31	-	-	-	-	-	-	-	-	-	-	
			10 ⁻³ in.lb.s ²	2.55	2.31	2.19	2.1	2.04	-	-	-	-	-	-	-	-	-	-	-

Please use our sizing software cymex[®] for a detailed sizing – www.wittenstein-cymex.com
Please contact us for optimum sizing at S1 conditions (Continuous operation).

- ^{a)} At max. 10 % F_{2QMax}
- ^{b)} Valid for standard clamping hub diameter
- ^{c)} Refers to center of the output shaft or flange
- ^{d)} Please reduce input speed at higher ambient temperatures
- ^{e)} Smooth shaft

1-stage

up to 19/28⁴⁾
(E⁵⁾/H) clamping
hub diameter

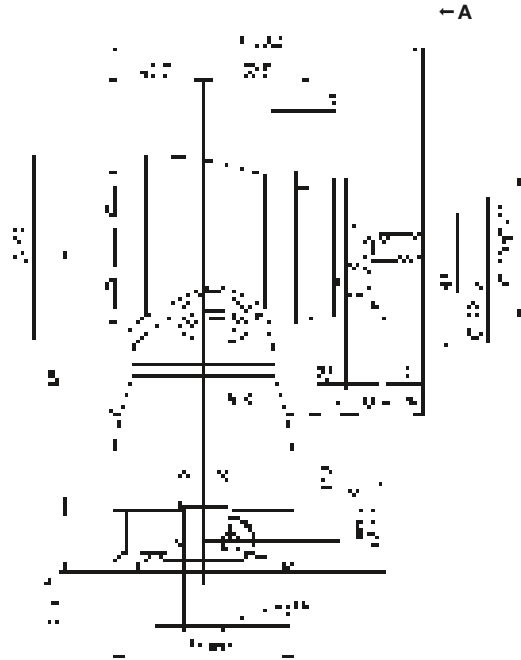
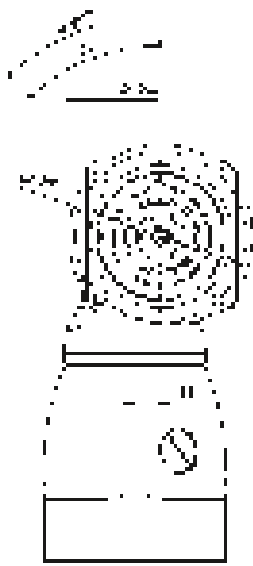

2-stage

up to 14/19⁴⁾
(C⁵⁾/E) clamping
hub diameter

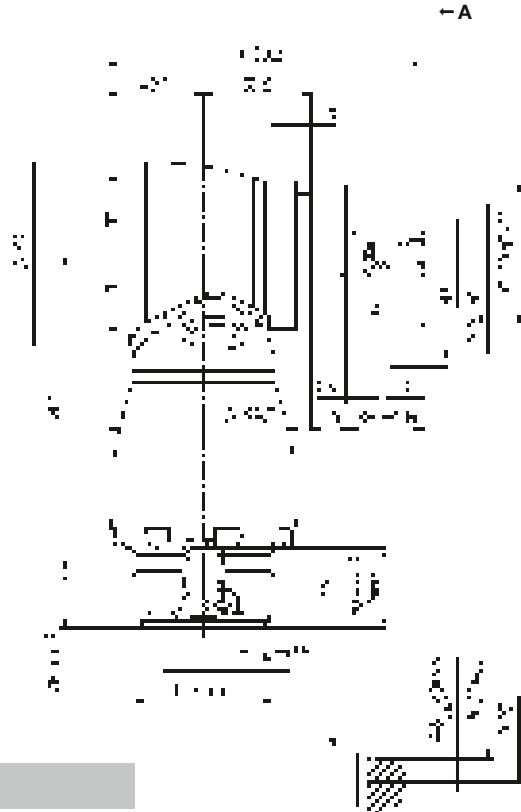
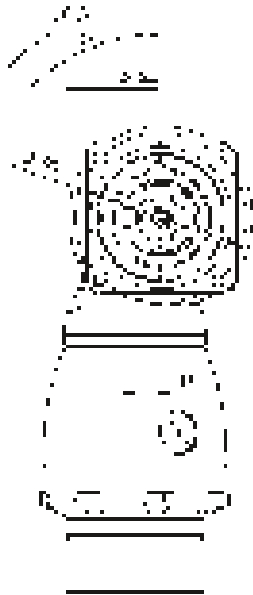

Motor shaft diameter [mm]

Other output variants

Shaft with key

Splined shaft (DIN 5480)



See technical data sheet for available clamping hub diameters (mass moment of inertia). Dimensions available on request.

Non-tolerated dimensions are nominal dimensions
1) Check motor shaft fit

2) Min./Max. permissible motor shaft length. Longer motor shafts are possible, please contact alpha.

3) The dimensions depend on the motor

4) Smaller motor shaft diameter is compensated by a bushing with a minimum thickness of 1 mm

5) Standard clamping hub diameter

SK+ 100 MF 1-/2-stage

			1-stage					2-stage											
Ratio	<i>i</i>		3	4	5	7	10	12	16	20	25	28	35	40	50	70	100		
Max. torque ^{a) b) e)}	T_{2a}	Nm	204	204	204	145	125	204	204	204	204	204	204	204	204	145	125		
		in.lb	1806	1806	1806	1283	1106	1806	1806	1806	1806	1806	1806	1806	1806	1806	1283	1106	
Max. acceleration torque ^{b) e)} (max. 1000 cycles per hour)	T_{2B}	Nm	170	170	170	145	125	170	170	170	170	170	170	170	170	145	125		
		in.lb	1505	1505	1505	1283	1106	1505	1505	1505	1505	1505	1505	1505	1505	1505	1283	1106	
Nominal torque (at n_n)	T_{2N}	Nm	100	100	100	90	80	100	100	100	100	100	100	100	100	90	80		
		in.lb	885	885	885	797	708	885	885	885	885	885	885	885	885	885	797	708	
Emergency stop torque ^{a) b) e)} (permitted 1000 times during the service life of the gearbox)	T_{2Not}	Nm	220	260	260	255	250	260	260	260	260	260	260	260	260	255	250		
		in.lb	1947	2301	2301	2257	2213	2301	2301	2301	2301	2301	2301	2301	2301	2301	2257	2213	
Permitted average input speed (at T_{2a} and 20 °C ambient temperature ^{d)})	n_{1N}	n_{1T}	2200	2400	2700	2500	2500	3100	3100	3100	3100	3100	3100	3100	3100	3500	4200	4200	
Max. input speed	n_{1Max}	rpm	5500	5500	5500	5500	5500	4500	4500	4500	4500	4500	4500	4500	4500	4500	4500		
Mean no load running torque ^{b)} (at $n_i = 3000$ rpm and 20 °C gearbox temperature)	T_{012}	Nm	3.8	3	2.3	3.5	2.8	0.6	0.6	0.5	0.4	0.4	0.3	0.2	0.2	0.2	0.2		
		in.lb	34	27	20	31	25	5	5	4	4	4	3	2	2	2	2		
Max. backlash	j_t	arcmin	Standard ≤ 4																
Torsional rigidity ^{b)}	C_{t21}	Nm/arcmin	10	11	13	13	13	11	11	11	11	11	11	11	13	13	13		
		in.lb/arcmin	89	97	115	115	115	97	97	97	97	97	97	97	97	115	115	115	
Max. axial force ^{c)}	F_{2AMax}	N	5700																
		lb _f	1283																
Max. lateral force ^{c)}	F_{2QMax}	N	6300																
		lb _f	1418																
Max. tilting moment	M_{2KMax}	Nm	833																
		in.lb	7373																
Efficiency at full load	η	%	96					94											
Service life	L_h	h	> 20000																
Weight (incl. standard adapter plate)	m	kg	9.3					10											
		lb _m	21					22											
Operating noise (at reference ratio and reference speed – ratio-specific values available in cymex [®])	L_{PA}	dB(A)	≤ 66																
Max. permitted housing temperature		°C	+90																
		F	194																
Ambient temperature		°C	0 to +40																
		F	32 to 104																
Lubrication			Lubricated for life																
Direction of rotation			In- and output opposite direction																
Protection class			IP 65																
Metal bellows coupling (recommended product type – validate sizing with cymex [®])			BC2 - 00200AA - 032.000 - X																
Bore diameter of coupling on the application side		mm	X = 022.000 - 045.000																
Mass moment of inertia (relates to the drive) Clamping hub diameter [mm]	E	19	J_i	kgcm ²	-	-	-	-	-	1.02	0.97	0.86	0.84	0.75	0.74	0.69	0.68	0.68	
				10 ⁻³ in.lb.s ²	-	-	-	-	-	0.9	0.86	0.76	0.74	0.66	0.65	0.61	0.61	0.6	0.6
	G	24	J_i	kgcm ²	-	-	-	-	-	2.59	2.54	2.42	2.4	2.31	2.3	2.26	2.25	2.25	2.25
				10 ⁻³ in.lb.s ²	-	-	-	-	-	2.29	2.25	2.14	2.12	2.04	2.04	2	1.99	1.99	1.99
	H	28	J_i	kgcm ²	4.64	3.8	3.34	2.98	2.79	-	-	-	-	-	-	-	-	-	-
				10 ⁻³ in.lb.s ²	4.11	3.36	2.96	2.64	2.47	-	-	-	-	-	-	-	-	-	-
	K	38	J_i	kgcm ²	11.9	11	10.6	10.2	10	-	-	-	-	-	-	-	-	-	-
				10 ⁻³ in.lb.s ²	10.53	9.74	9.38	9.03	8.85	-	-	-	-	-	-	-	-	-	-

Please use our sizing software cymex[®] for a detailed sizing – www.wittenstein-cymex.com
Please contact us for optimum sizing at S1 conditions (Continuous operation).

- ^{a)} At max. 10 % F_{2QMax}
- ^{b)} Valid for standard clamping hub diameter
- ^{c)} Refers to center of the output shaft or flange
- ^{d)} Please reduce input speed at higher ambient temperatures
- ^{e)} Smooth shaft

1-stage

up to 28/38⁴⁾
(H⁵⁾/K) clamping
hub diameter

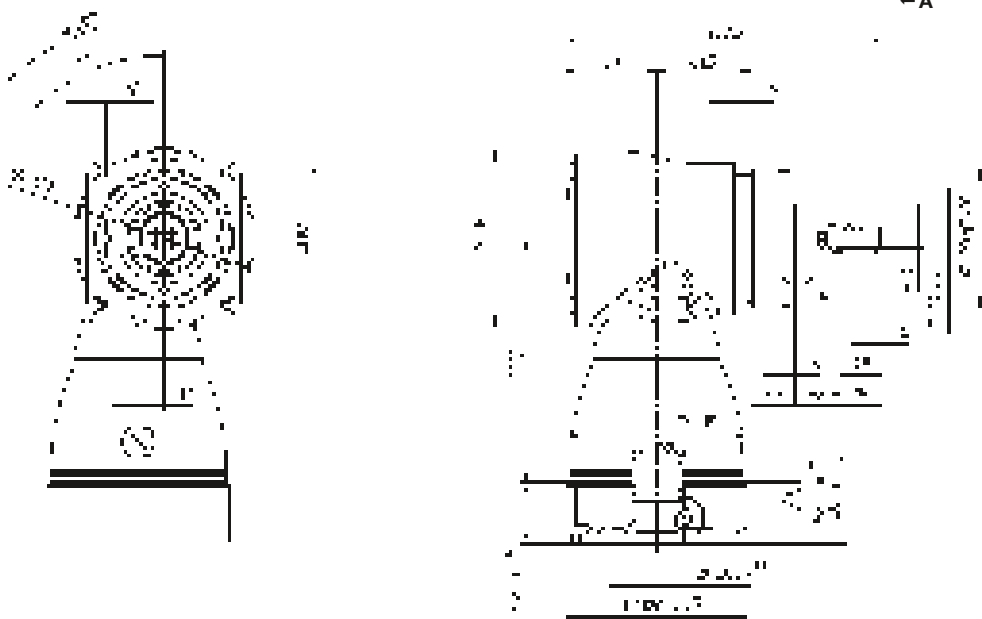

2-stage

up to 19/24⁴⁾
(E⁵⁾/G) clamping
hub diameter

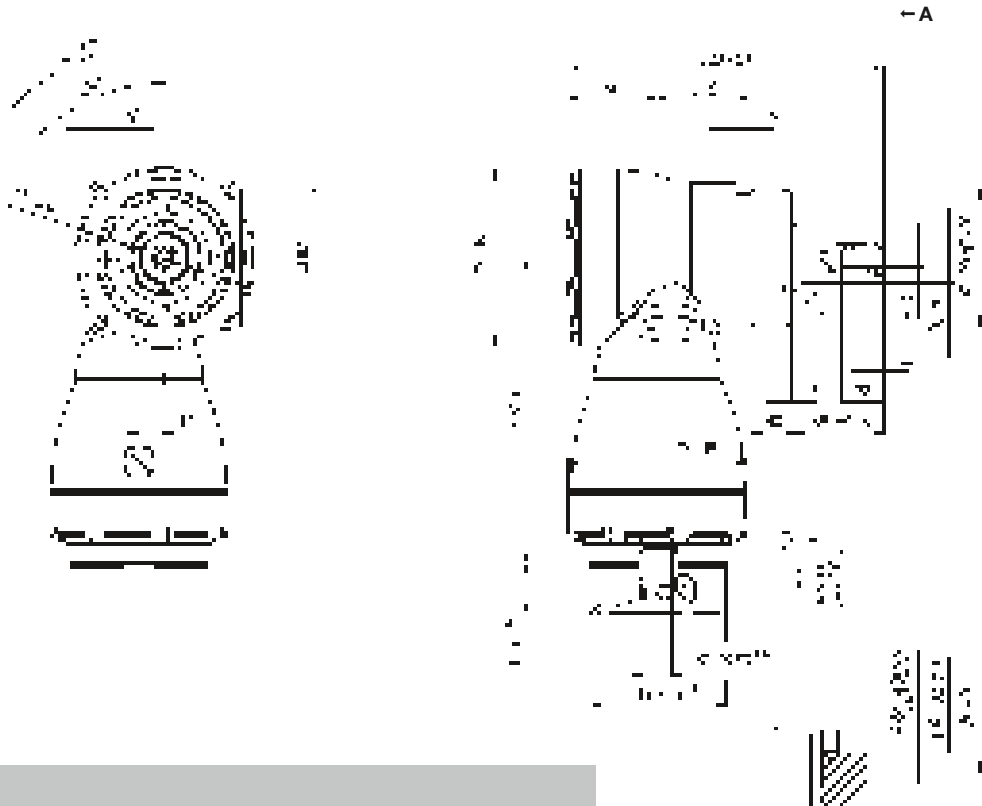

Motor shaft diameter [mm]

Other output variants

Shaft with key

Splined shaft (DIN 5480)

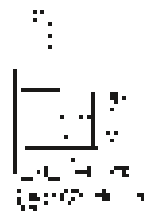
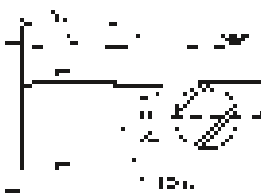

See technical data sheet for available clamping hub diameters (mass moment of inertia). Dimensions available on request.

Non-tolerated dimensions are nominal dimensions
1) Check motor shaft fit

2) Min./Max. permissible motor shaft length. Longer motor shafts are possible, please contact alpha.

3) The dimensions depend on the motor

4) Smaller motor shaft diameter is compensated by a bushing with a minimum thickness of 1 mm

5) Standard clamping hub diameter

SK+ 140 MF 1-/2-stage

			1-stage					2-stage											
Ratio	<i>i</i>		3	4	5	7	10	12	16	20	25	28	35	40	50	70	100		
Max. torque ^{a) b) e)}	T_{2a}	Nm	360	360	360	250	210	360	360	360	360	360	360	360	360	250	210		
		in.lb	3186	3186	3186	2213	1859	3186	3186	3186	3186	3186	3186	3186	3186	2213	1859		
Max. acceleration torque ^{b) e)} (max. 1000 cycles per hour)	T_{2B}	Nm	300	300	300	250	210	300	300	300	300	300	300	300	300	250	210		
		in.lb	2655	2655	2655	2213	1859	2655	2655	2655	2655	2655	2655	2655	2655	2213	1859		
Nominal torque (at n_n)	T_{2N}	Nm	190	190	190	175	160	190	190	190	190	190	190	190	190	175	160		
		in.lb	1682	1682	1682	1549	1416	1682	1682	1682	1682	1682	1682	1682	1682	1549	1416		
Emergency stop torque ^{a) b) e)} (permitted 1000 times during the service life of the gearbox)	T_{2Not}	Nm	400	500	500	450	400	500	500	500	500	500	500	500	500	450	400		
		in.lb	3540	4425	4425	3983	3540	4425	4425	4425	4425	4425	4425	4425	4425	3983	3540		
Permitted average input speed (at T_{2a} and 20 °C ambient temperature) ^{d)}	n_{1N}	n_{1T}	1900	2000	2200	2000	2000	2900	2900	2900	2900	2900	2900	2900	3200	3200	3900		
Max. input speed	n_{1Max}	rpm	5000	5000	5000	5000	5000	4500	4500	4500	4500	4500	4500	4500	4500	4500	4500		
Mean no load running torque ^{b)} (at $n_1 = 3000$ rpm and 20 °C gearbox temperature)	T_{012}	Nm	7	5.2	4.5	7.5	5.5	1.4	0.9	0.7	0.5	0.5	0.4	0.4	0.3	0.3	0.3		
		in.lb	62	46	40	66	49	12	8	6	4	4	4	4	3	3	3		
Max. backlash	j_t	arcmin	Standard ≤ 4																
Torsional rigidity ^{b)}	C_{t21}	Nm/arcmin	27	30	32	32	32	29	29	29	29	29	29	29	31	31	31		
		in.lb/arcmin	239	266	283	283	283	257	257	257	257	257	257	257	274	274	274		
Max. axial force ^{c)}	F_{2AMax}	N	9900																
		lb _f	2228																
Max. lateral force ^{c)}	F_{2QMax}	N	9500																
		lb _f	2138																
Max. tilting moment	M_{2KMax}	Nm	1692																
		in.lb	14976																
Efficiency at full load	η	%	96					94											
Service life	L_h	h	> 20000																
Weight (incl. standard adapter plate)	m	kg	22.6					25											
		lb _m	50					55											
Operating noise (at reference ratio and reference speed – ratio-specific values available in cymex [®])	L_{PA}	dB(A)	≤ 68																
Max. permitted housing temperature		°C	+90																
		F	194																
Ambient temperature		°C	0 to +40																
		F	32 to 104																
Lubrication			Lubricated for life																
Direction of rotation			In- and output opposite direction																
Protection class			IP 65																
Metal bellows coupling (recommended product type – validate sizing with cymex [®])			BC2 - 00300AA - 040.000 - X																
Bore diameter of coupling on the application side		mm	X = 024.000 - 060.000																
Mass moment of inertia (relates to the drive)	G	24	J_1	kgcm ²	-	-	-	-	-	4.21	3.85	3.28	3.17	2.78	2.73	2.48	2.46	2.43	2.42
				10 ⁻³ in.lb.s ²	-	-	-	-	-	3.73	3.41	2.9	2.81	2.46	2.42	2.19	2.18	2.15	2.14
Clamping hub diameter [mm]	K	38	J_1	kgcm ²	25	19.1	16.3	14.1	12.8	11.1	10.7	10.2	10.1	9.69	9.64	9.39	9.37	9.34	9.33
				10 ⁻³ in.lb.s ²	22.13	16.9	14.43	12.48	11.33	9.82	9.47	9.03	8.94	8.58	8.53	8.31	8.29	8.27	8.26

Please use our sizing software cymex[®] for a detailed sizing – www.wittenstein-cymex.com
Please contact us for optimum sizing at S1 conditions (Continuous operation).

- ^{a)} At max. 10 % F_{2QMax}
- ^{b)} Valid for standard clamping hub diameter
- ^{c)} Refers to center of the output shaft or flange
- ^{d)} Please reduce input speed at higher ambient temperatures
- ^{e)} Smooth shaft

View A

1-stage

up to 38⁴⁾ (K⁵⁾
clamping hub diameter

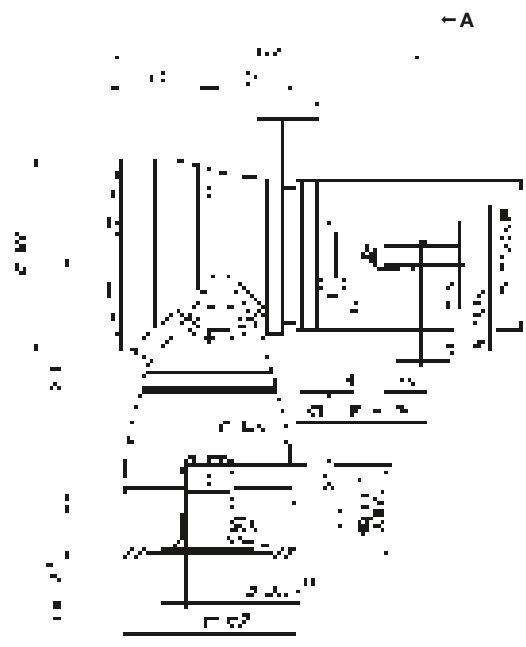
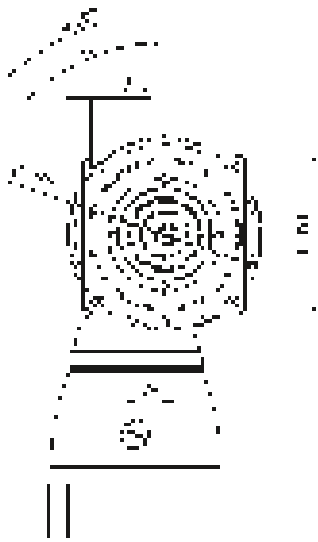

2-stage

up to 24/38⁴⁾
(G⁵⁾/K clamping
hub diameter

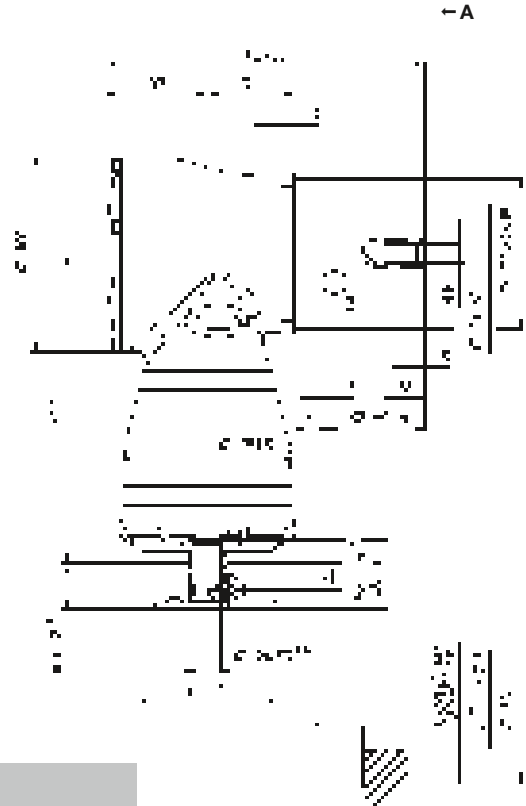
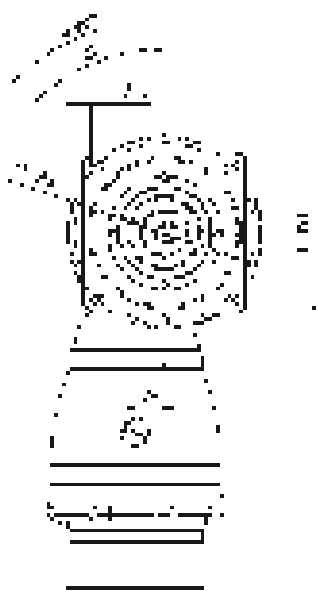

Motor shaft diameter [mm]

Hypoid gearboxes

SK⁺

Other output variants

Shaft with key

Splined shaft (DIN 5480)

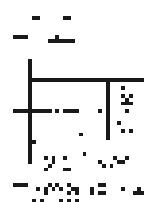
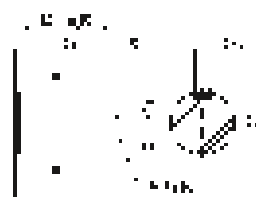

See technical data sheet for available clamping hub diameters (mass moment of inertia). Dimensions available on request.

- Non-tolerated dimensions are nominal dimensions
- ¹⁾ Check motor shaft fit
- ²⁾ Min./Max. permissible motor shaft length. Longer motor shafts are possible, please contact alpha.
- ³⁾ The dimensions depend on the motor
- ⁴⁾ Smaller motor shaft diameter is compensated by a bushing with a minimum thickness of 1 mm
- ⁵⁾ Standard clamping hub diameter

SK+ 180 MF 1-/2-stage

			1-stage					2-stage											
Ratio	<i>i</i>		3	4	5	7	10	12	16	20	25	28	35	40	50	70	100		
Max. torque ^{a) b) e)}	T_{2a}	Nm	768	768	768	550	470	768	768	768	768	768	768	768	768	550	470		
		in.lb	6797	6797	6797	4868	4160	6797	6797	6797	6797	6797	6797	6797	6797	6797	4868	4160	
Max. acceleration torque ^{b) e)} (max. 1000 cycles per hour)	T_{2B}	Nm	640	640	640	550	470	640	640	640	640	640	640	640	640	550	470		
		in.lb	5665	5665	5665	4868	4160	5665	5665	5665	5665	5665	5665	5665	5665	5665	4868	4160	
Nominal torque (at n_n)	T_{2N}	Nm	400	400	400	380	360	400	400	400	400	400	400	400	400	380	360		
		in.lb	3540	3540	3540	3363	3186	3540	3540	3540	3540	3540	3540	3540	3540	3540	3363	3186	
Emergency stop torque ^{a) b) e)} (permitted 1000 times during the service life of the gearbox)	T_{2Not}	Nm	900	1050	1050	970	900	1050	1050	1050	1050	1050	1050	1050	1050	970	900		
		in.lb	7966	9293	9293	8585	7966	9293	9293	9293	9293	9293	9293	9293	9293	9293	8585	7966	
Permitted average input speed (at T_{2a} and 20 °C ambient temperature) ^{d)}	n_{1N}	n_{1T}	1600	1800	2000	1800	1800	2700	2700	2700	2700	2700	2700	2700	2900	3200	3400		
Max. input speed	n_{1Max}	rpm	4500	4500	4500	4500	4500	4000	4000	4000	4000	4000	4000	4000	4000	4000	4000		
Mean no load running torque ^{b)} (at $n_1 = 3000$ rpm and 20 °C gearbox temperature)	T_{012}	Nm	14.5	12	10	15	12.5	3	2.3	1.8	1.6	1.3	1.2	0.9	0.9	0.9	0.9		
		in.lb	128	106	89	133	111	27	20	16	14	12	11	8	8	8	8		
Max. backlash	j_t	arcmin	Standard ≤ 4																
Torsional rigidity ^{b)}	C_{t21}	Nm/arcmin	64	71	79	78	77	71	71	71	71	71	71	71	78	78	78		
		in.lb/arcmin	566	628	699	690	682	628	628	628	628	628	628	628	690	690	690		
Max. axial force ^{c)}	F_{2AMax}	N	14200																
		lb _f	3195																
Max. lateral force ^{c)}	F_{2QMax}	N	14700																
		lb _f	3308																
Max. tilting moment	M_{2KMax}	Nm	3213																
		in.lb	28438																
Efficiency at full load	η	%	96					94											
Service life	L_h	h	> 20000																
Weight (incl. standard adapter plate)	m	kg	45.4					48											
		lb _m	100					106											
Operating noise (at reference ratio and reference speed – ratio-specific values available in cymex [®])	L_{PA}	dB(A)	≤ 68																
		°C	+90																
Max. permitted housing temperature	F	°C	194																
		°C	0 to +40																
Ambient temperature	F	°C	32 to 104																
		°C	32 to 104																
Lubrication			Lubricated for life																
Direction of rotation			In- and output opposite direction																
Protection class			IP 65																
Metal bellows coupling (recommended product type – validate sizing with cymex [®])			BC2 - 00800AA - 055.000 - X																
Bore diameter of coupling on the application side		mm	X = 040.000 - 075.000																
Mass moment of inertia (relates to the drive)	K	38	J_1	kgcm ²	-	-	-	-	-	15.3	14	12.3	12	10.9	10.7	10.1	10	9.95	9.91
				10 ⁻³ in.lb.s ²	-	-	-	-	-	13.54	12.39	10.89	10.62	9.65	9.47	8.94	8.85	8.81	8.77
Clamping hub diameter [mm]	M	48	J_1	kgcm ²	73.3	51.6	42.1	34	29.7	30	28.7	27.1	26.7	25.6	25.4	24.8	24.7	24.7	24.6
				10 ⁻³ in.lb.s ²	64.87	45.67	37.26	30.09	26.28	26.55	25.4	23.98	23.63	22.66	22.48	21.95	21.86	21.86	21.77

Please use our sizing software cymex[®] for a detailed sizing – www.wittenstein-cymex.com
Please contact us for optimum sizing at S1 conditions (Continuous operation).

- ^{a)} At max. 10 % F_{2QMax}
- ^{b)} Valid for standard clamping hub diameter
- ^{c)} Refers to center of the output shaft or flange
- ^{d)} Please reduce input speed at higher ambient temperatures
- ^{e)} Smooth shaft

1-stage

up to 48⁴⁾ (M)⁵⁾
clamping hub diameter

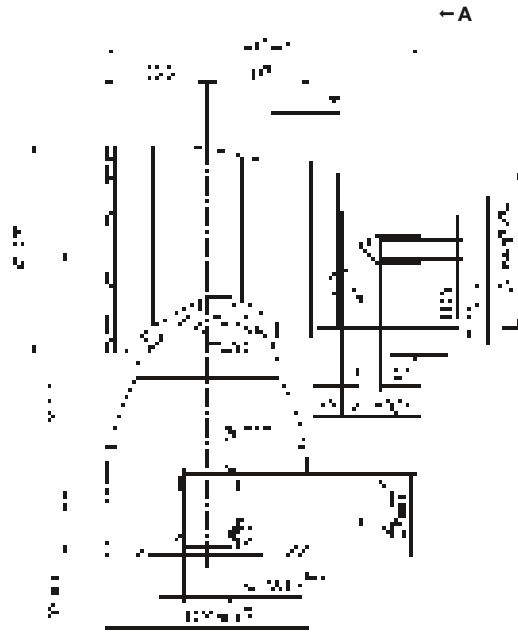
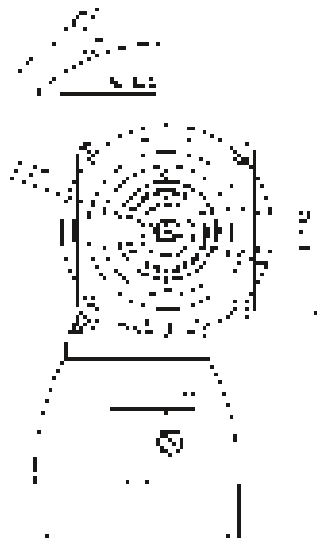

2-stage

up to 38/48⁴⁾
(K⁵⁾/M) clamping
hub diameter

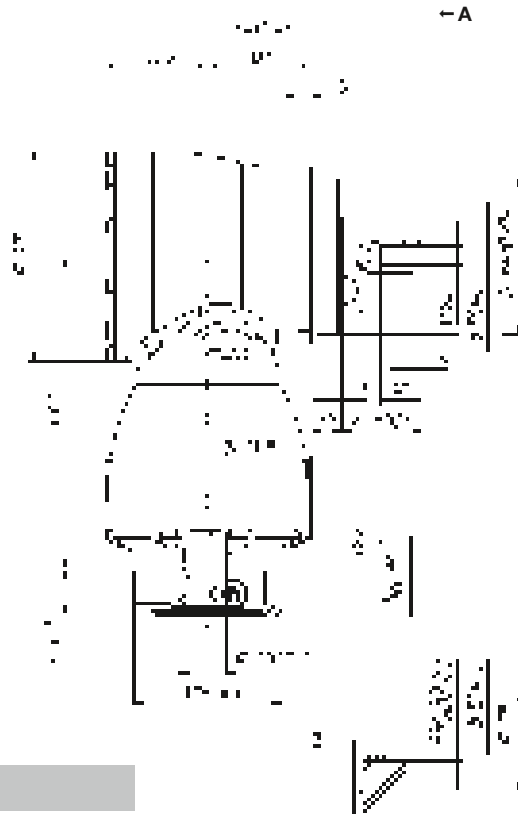
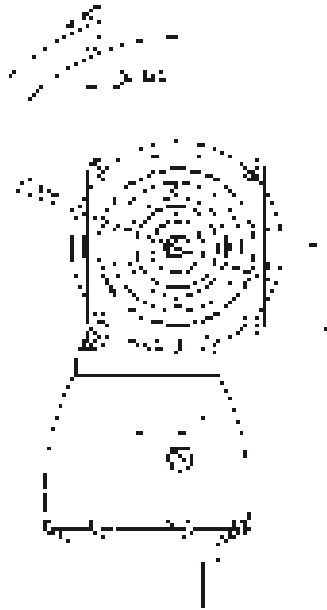

Motor shaft diameter [mm]

Other output variants

Shaft with key

Splined shaft (DIN 5480)

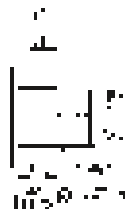

See technical data sheet for available clamping hub diameters (mass moment of inertia). Dimensions available on request.

Non-tolerated dimensions are nominal dimensions
1) Check motor shaft fit

2) Min./Max. permissible motor shaft length. Longer motor shafts are possible, please contact alpha.

3) The dimensions depend on the motor

4) Smaller motor shaft diameter is compensated by a bushing with a minimum thickness of 1 mm

5) Standard clamping hub diameter

SPK+ 075 MF 2-stage

			2-stage											
Ratio	<i>i</i>		12	16	20	25	28	35	40	50	70	100		
Max. torque ^{a) b) e)}	T_{2a}	Nm	144	144	176	176	176	176	80	100	140	152		
		in.lb	1275	1275	1558	1558	1558	1558	708	885	1239	1345		
Max. acceleration torque ^{b) e)} (max. 1000 cycles per hour)	T_{2B}	Nm	120	120	132	132	132	132	80	100	132	114		
		in.lb	1062	1062	1168	1168	1168	1168	708	885	1168	1009		
Nominal torque (at n_n)	T_{2N}	Nm	75	75	75	75	75	75	60	75	75	52		
		in.lb	664	664	664	664	664	664	531	664	664	460		
Emergency stop torque ^{a) b) e)} (permitted 1000 times during the service life of the gearbox)	T_{2Not}	Nm	160	200	250	250	250	250	160	200	250	250		
		in.lb	1416	1770	2213	2213	2213	2213	1416	1770	2213	2213		
Permitted average input speed (at T_{2a} and 20 °C ambient temperature) ^{d)}	n_{1N}	n_{1T}	2000	2400	2400	2700	2400	2500	2500	2500	2500	2500		
Max. input speed	n_{1Max}	rpm	7500	7500	7500	7500	7500	7500	7500	7500	7500	7500		
Mean no load running torque ^{b)} (at $n_1 = 3000$ rpm and 20 °C gearbox temperature)	T_{012}	Nm	1.5	1.3	1.2	1.2	1.2	1.3	1.3	1.3	1.3	1.3		
		in.lb	13	12	11	11	11	12	12	12	12	12		
Max. backlash	j_t	arcmin	Standard ≤ 5 / Reduced ≤ 3											
Torsional rigidity ^{b)}	C_{t21}	Nm/arcmin	10	10	10	10	10	10	10	10	10	10		
		in.lb/arcmin	89	89	89	89	89	89	89	89	89	89		
Max. axial force ^{c)}	F_{2AMax}	N	3350											
		lb _f	754											
Max. lateral force ^{c)}	F_{2QMax}	N	4000											
		lb _f	900											
Max. tilting moment	M_{2KMax}	Nm	236											
		in.lb	2089											
Efficiency at full load	η	%	94											
Service life	L_h	h	> 20000											
Weight (incl. standard adapter plate)	m	kg	5.2											
		lb _m	11											
Operating noise (at reference ratio and reference speed – ratio-specific values available in cymex [®])	L_{PA}	dB(A)	≤ 66											
		°C	+90											
Max. permitted housing temperature		F	194											
		°C	0 to +40											
Ambient temperature		F	32 to 104											
Lubrication			Lubricated for life											
Direction of rotation			In- and output opposite direction											
Protection class			IP 65											
Metal bellows coupling (recommended product type – validate sizing with cymex [®])			BC2 - 00150AA - 022.000 - X											
Bore diameter of coupling on the application side		mm	X = 019.000 - 042.000											
Mass moment of inertia (relates to the drive)	C	14	J_1	kgcm ²	0.54	0.45	0.44	0.4	0.44	0.36	0.35	0.34	0.34	0.34
				10 ⁻³ in.lb.s ²	0.48	0.4	0.39	0.35	0.39	0.32	0.31	0.3	0.3	0.3
Clamping hub diameter [mm]	E	19	J_1	kgcm ²	0.89	0.8	0.79	0.75	0.79	0.71	0.7	0.7	0.7	0.69
				10 ⁻³ in.lb.s ²	0.79	0.71	0.7	0.66	0.7	0.63	0.62	0.62	0.62	0.61

Please use our sizing software cymex[®] for a detailed sizing – www.wittenstein-cymex.com
Please contact us for optimum sizing at S1 conditions (Continuous operation).

- ^{a)} At max. 10 % F_{2QMax}
- ^{b)} Valid for standard clamping hub diameter
- ^{c)} Refers to center of the output shaft or flange
- ^{d)} Please reduce input speed at higher ambient temperatures
- ^{e)} Smooth shaft

View A

Motor shaft diameter [mm]

2-stage

up to 14/19⁴⁾
(C⁵⁾/E) clamping
hub diameter

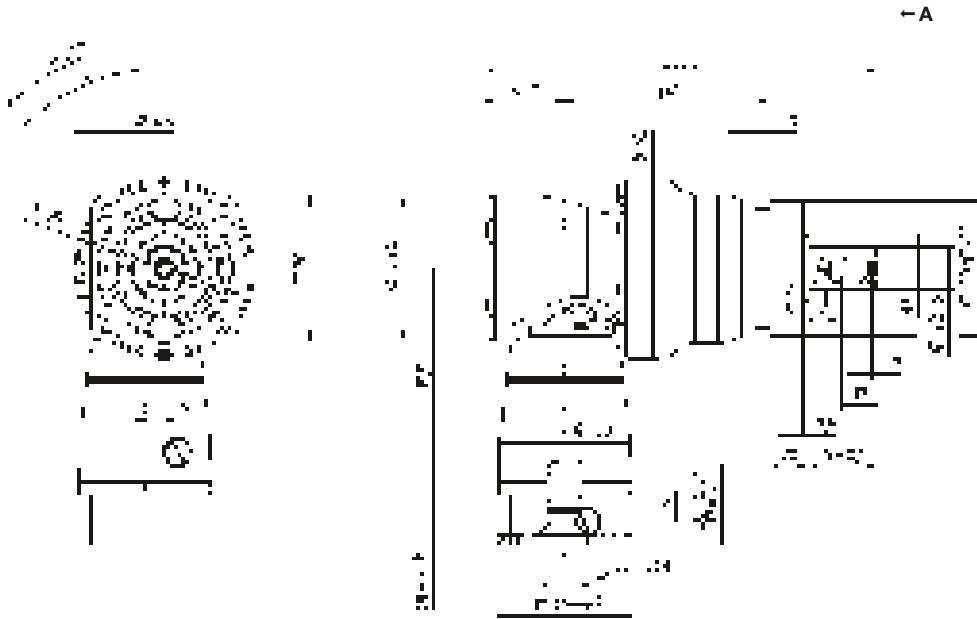

Hypoid gearboxes

SPK

Other output variants

Shaft with key

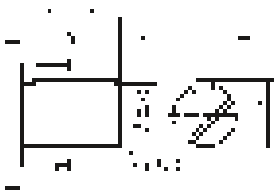

Splined shaft (DIN 5480)

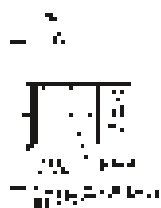

Shaft mounted



See technical data sheet for available clamping hub diameters (mass moment of inertia). Dimensions available on request.

Non-tolerated dimensions are nominal dimensions

- ¹⁾ Check motor shaft fit
- ²⁾ Min./Max. permissible motor shaft length. Longer motor shafts are possible, please contact alpha.
- ³⁾ The dimensions depend on the motor
- ⁴⁾ Smaller motor shaft diameter is compensated by a bushing with a minimum thickness of 1 mm
- ⁵⁾ Standard clamping hub diameter

SPK+ 075 MF 3-stage

			3-stage													
Ratio	<i>i</i>		64	84	100	125	140	175	200	250	280	350	400	500	700	1000
Max. torque ^{a) b) e)}	T_{2a}	Nm	144	144	176	176	176	176	176	176	176	176	80	100	140	152
		in.lb	1275	1275	1558	1558	1558	1558	1558	1558	1558	1558	1558	708	885	1239
Max. acceleration torque ^{b) e)} (max. 1000 cycles per hour)	T_{2B}	Nm	120	120	132	132	132	132	132	132	132	132	80	100	132	114
		in.lb	1062	1062	1168	1168	1168	1168	1168	1168	1168	1168	1168	708	885	1168
Nominal torque (at n_n)	T_{2N}	Nm	75	75	75	75	75	75	75	75	75	75	60	75	75	52
		in.lb	664	664	664	664	664	664	664	664	664	664	664	531	664	664
Emergency stop torque ^{a) b) e)} (permitted 1000 times during the service life of the gearbox)	T_{2Not}	Nm	200	160	250	250	250	250	250	250	250	250	160	200	250	250
		in.lb	1770	1416	2213	2213	2213	2213	2213	2213	2213	2213	2213	1416	1770	2213
Permitted average input speed (at T_{2a} and 20 °C ambient temperature) ^{d)}	n_{1N}	n_{1T}	4400	4400	4400	4400	4400	4400	4400	4800	4400	4800	5500	5500	5500	5500
Max. input speed	n_{1Max}	rpm	6000	6000	6000	6000	6000	6000	6000	6000	6000	6000	6000	6000	6000	6000
Mean no load running torque ^{b)} (at $n_1 = 3000$ rpm and 20 °C gearbox temperature)	T_{012}	Nm	0.3	0.3	0.3	0.3	0.3	0.3	0.2	0.2	0.2	0.2	0.2	0.2	0.2	0.2
		in.lb	3	3	3	3	3	3	2	2	2	2	2	2	2	2
Max. backlash	j_t	arcmin	Standard ≤ 5 / Reduced ≤ 3													
Torsional rigidity ^{b)}	C_{t21}	Nm/arcmin	10	10	10	10	10	10	10	10	10	10	10	10	10	10
		in.lb/arcmin	89	89	89	89	89	89	89	89	89	89	89	89	89	89
Max. axial force ^{c)}	F_{2AMax}	N	3350													
		lb _f	754													
Max. lateral force ^{c)}	F_{2QMax}	N	4000													
		lb _f	900													
Max. tilting moment	M_{2KMax}	Nm	236													
		in.lb	2089													
Efficiency at full load	η	%	92													
Service life	L_h	h	> 20000													
Weight (incl. standard adapter plate)	<i>m</i>	kg	5.5													
		lb _m	12													
Operating noise (at reference ratio and reference speed – ratio-specific values available in cymex [®])	L_{PA}	dB(A)	≤ 66													
		°C	+90													
Max. permitted housing temperature		F	194													
		°C	0 to +40													
Ambient temperature		F	32 to 104													
Lubrication			Lubricated for life													
Direction of rotation			In- and output opposite direction													
Protection class			IP 65													
Metal bellows coupling (recommended product type – validate sizing with cymex [®])			BC2 - 00150AA - 022.000 - X													
		Bore diameter of coupling on the application side	mm	X = 019.000 - 042.000												
Mass moment of inertia (relates to the drive)	B	11	J_1	kgcm ²	0.09	0.07	0.08	0.07	0.06	0.06	0.06	0.06	0.06	0.06	0.06	0.06
				10 ⁻³ in.lb.s ²	0.08	0.06	0.07	0.06	0.05	0.05	0.05	0.05	0.05	0.05	0.05	0.05
Clamping hub diameter [mm]	C	14	J_1	kgcm ²	0.2	0.18	0.19	0.19	0.18	0.18	0.17	0.17	0.17	0.17	0.17	0.17
				10 ⁻³ in.lb.s ²	0.18	0.16	0.17	0.17	0.16	0.16	0.15	0.15	0.15	0.15	0.15	0.15

Please use our sizing software cymex[®] for a detailed sizing – www.wittenstein-cymex.com
Please contact us for optimum sizing at S1 conditions (Continuous operation).

- ^{a)} At max. 10 % F_{2QMax}
- ^{b)} Valid for standard clamping hub diameter
- ^{c)} Refers to center of the output shaft or flange
- ^{d)} Please reduce input speed at higher ambient temperatures
- ^{e)} Smooth shaft

View A

Motor shaft diameter [mm]

3-stage

up to 11/14⁴⁾
(B⁵⁾/C) clamping
hub diameter

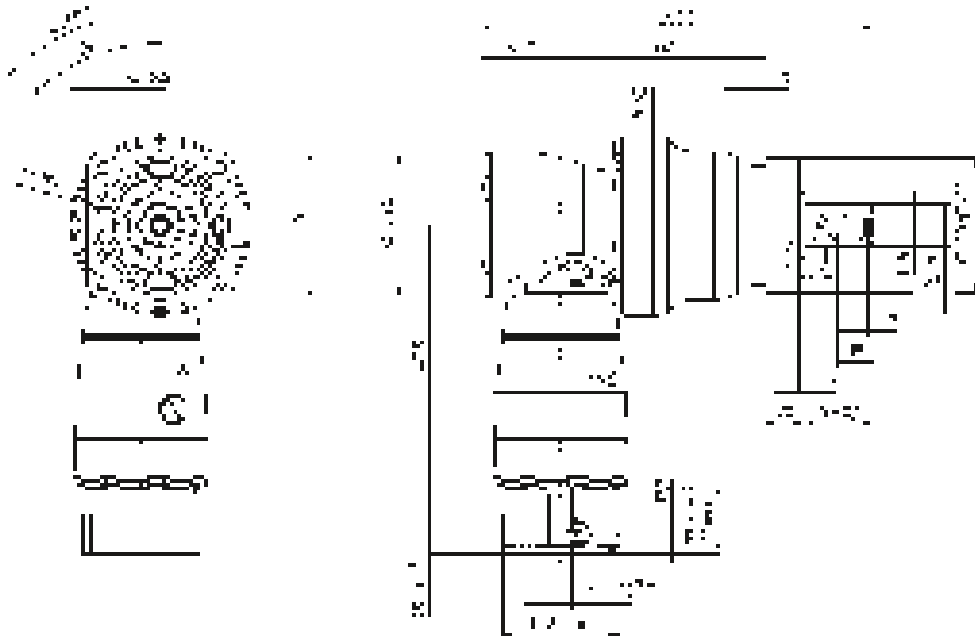

Hypoid gearboxes

SPK

Other output variants

Shaft with key

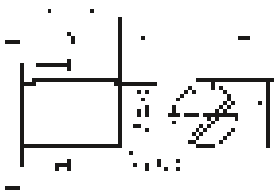

Splined shaft (DIN 5480)

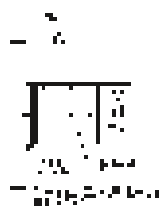

Shaft mounted

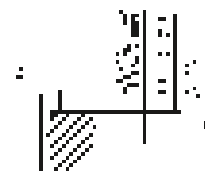

See technical data sheet for available clamping hub diameters (mass moment of inertia). Dimensions available on request.

Non-tolerated dimensions are nominal dimensions

- ¹⁾ Check motor shaft fit
- ²⁾ Min./Max. permissible motor shaft length. Longer motor shafts are possible, please contact alpha.
- ³⁾ The dimensions depend on the motor
- ⁴⁾ Smaller motor shaft diameter is compensated by a bushing with a minimum thickness of 1 mm
- ⁵⁾ Standard clamping hub diameter

SPK+ 100 MF 2-stage

			2-stage										
Ratio	i		12	16	20	25	28	35	40	50	70	100	
Max. torque ^{a) b) e)}	T_{2a}	Nm	336	336	420	420	428	428	200	250	350	376	
		in.lb	2974	2974	3717	3717	3788	3788	1770	2213	3098	3328	
Max. acceleration torque ^{b) e)} (max. 1000 cycles per hour)	T_{2B}	Nm	280	280	350	350	378	378	200	250	350	282	
		in.lb	2478	2478	3098	3098	3346	3346	1770	2213	3098	2496	
Nominal torque (at n_n)	T_{2N}	Nm	180	180	175	175	170	170	160	175	170	120	
		in.lb	1593	1593	1549	1549	1505	1505	1416	1549	1505	1062	
Emergency stop torque ^{a) b) e)} (permitted 1000 times during the service life of the gearbox)	T_{2Not}	Nm	380	460	575	575	625	625	400	500	625	625	
		in.lb	3363	4071	5089	5089	5532	5532	3540	4425	5532	5532	
Permitted average input speed (at T_{2a} and 20 °C ambient temperature) ^{d)}	n_{1N}	n_{1T}	2000	2400	2400	2700	2400	2500	2500	2500	2500	2500	
Max. input speed	n_{1Max}	rpm	7500	7500	7500	7500	7500	7500	7500	7500	7500	7500	
Mean no load running torque ^{b)} (at $n_1 = 3000$ rpm and 20 °C gearbox temperature)	T_{012}	Nm	2.5	2.1	2	1.8	2	2.2	2	2	2	2	
		in.lb	22	19	18	16	18	19	18	18	18	18	
Max. backlash	j_t	arcmin	Standard ≤ 4 / Reduced ≤ 2										
Torsional rigidity ^{b)}	C_{t21}	Nm/arcmin	31	31	31	31	31	31	31	31	31	31	
		in.lb/arcmin	274	274	274	274	274	274	274	274	274	274	
Max. axial force ^{c)}	F_{2AMax}	N	5650										
		lb _f	1271										
Max. lateral force ^{c)}	F_{2QMax}	N	6300										
		lb _f	1418										
Max. tilting moment	M_{2KMax}	Nm	487										
		in.lb	4310										
Efficiency at full load	η	%	94										
Service life	L_h	h	> 20000										
Weight (incl. standard adapter plate)	m	kg	9.7										
		lb _m	21										
Operating noise (at reference ratio and reference speed – ratio-specific values available in cymex [®])	L_{PA}	dB(A)	≤ 68										
		°C	+90										
Max. permitted housing temperature		F	194										
		°C	0 to +40										
Ambient temperature		F	32 to 104										
Lubrication			Lubricated for life										
Direction of rotation			In- and output opposite direction										
Protection class			IP 65										
Metal bellows coupling (recommended product type – validate sizing with cymex [®])			BC2 - 00300AA - 032.000 - X										
Bore diameter of coupling on the application side		mm	X = 024.000 - 060.000										
Mass moment of inertia (relates to the drive)	E	19	J_1	kgcm ²	1.48	1.2	1.17	1.05	1.15	0.95	0.9	0.89	0.89
				10 ⁻³ in.lb.s ²	1.31	1.06	1.04	0.93	1.02	0.84	0.8	0.79	0.79
Clamping hub diameter [mm]	H	28	J_1	kgcm ²	2.89	2.62	2.59	2.46	2.56	2.36	2.31	2.31	2.3
				10 ⁻³ in.lb.s ²	2.56	2.32	2.29	2.18	2.27	2.09	2.04	2.04	2.04

Please use our sizing software cymex[®] for a detailed sizing – www.wittenstein-cymex.com
Please contact us for optimum sizing at S1 conditions (Continuous operation).

- ^{a)} At max. 10 % F_{2QMax}
- ^{b)} Valid for standard clamping hub diameter
- ^{c)} Refers to center of the output shaft or flange
- ^{d)} Please reduce input speed at higher ambient temperatures
- ^{e)} Smooth shaft

View A

Motor shaft diameter [mm]

2-stage

up to 19/28⁴⁾
(E⁵⁾/H) clamping
hub diameter



Hypoid gearboxes

SPK

Other output variants

Shaft with key

Splined shaft (DIN 5480)

Shaft mounted

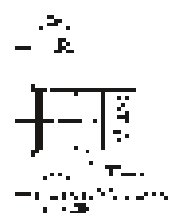
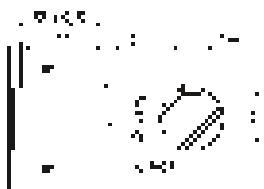
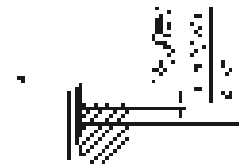

See technical data sheet for available clamping hub diameters (mass moment of inertia). Dimensions available on request.

Non-tolerated dimensions are nominal dimensions
¹⁾ Check motor shaft fit

²⁾ Min./Max. permissible motor shaft length. Longer motor shafts are possible, please contact alpha.

³⁾ The dimensions depend on the motor

⁴⁾ Smaller motor shaft diameter is compensated by a bushing with a minimum thickness of 1 mm

⁵⁾ Standard clamping hub diameter

SPK+ 100 MF 3-stage

			3-stage														
Ratio	<i>i</i>		64	84	100	125	140	175	200	250	280	350	400	500	700	1000	
Max. torque ^{a) b) e)}	T_{2a}	Nm	336	336	420	420	420	420	420	420	428	428	200	250	350	376	
		in.lb	2974	2974	3717	3717	3717	3717	3717	3717	3788	3788	1770	2213	3098	3328	
Max. acceleration torque ^{b) e)} (max. 1000 cycles per hour)	T_{2B}	Nm	280	280	350	350	350	350	350	350	378	378	200	250	350	282	
		in.lb	2478	2478	3098	3098	3098	3098	3098	3098	3346	3346	1770	2213	3098	2496	
Nominal torque (at n_n)	T_{2N}	Nm	180	180	175	175	175	175	175	175	170	170	160	175	170	120	
		in.lb	1593	1593	1549	1549	1549	1549	1549	1549	1505	1505	1416	1549	1505	1062	
Emergency stop torque ^{a) b) e)} (permitted 1000 times during the service life of the gearbox)	T_{2Not}	Nm	460	380	575	575	575	575	575	575	625	625	400	500	625	625	
		in.lb	4071	3363	5089	5089	5089	5089	5089	5089	5532	5532	3540	4425	5532	5532	
Permitted average input speed (at T_{2a} and 20 °C ambient temperature) ^{d)}	n_{1N}	n_{1T}	3500	3500	3500	3500	3500	3500	3500	3800	3500	3800	4500	4500	4500	4500	
Max. input speed	n_{1Max}	rpm	6000	6000	6000	6000	6000	6000	6000	6000	6000	6000	6000	6000	6000	6000	
Mean no load running torque ^{b)} (at $n_i = 3000$ rpm and 20 °C gearbox temperature)	T_{012}	Nm	0.4	0.3	0.3	0.3	0.3	0.3	0.2	0.2	0.2	0.2	0.2	0.2	0.2	0.2	
		in.lb	4	3	3	3	3	3	2	2	2	2	2	2	2	2	
Max. backlash	j_t	arcmin	Standard ≤ 4 / Reduced ≤ 2														
Torsional rigidity ^{b)}	C_{t21}	Nm/arcmin	31	31	31	31	31	31	31	31	31	31	31	31	31	31	
		in.lb/arcmin	274	274	274	274	274	274	274	274	274	274	274	274	274	274	
Max. axial force ^{c)}	F_{2AMax}	N	5650														
		lb _f	1271														
Max. lateral force ^{c)}	F_{2QMax}	N	6300														
		lb _f	1418														
Max. tilting moment	M_{2KMax}	Nm	487														
		in.lb	4310														
Efficiency at full load	η	%	92														
Service life	L_h	h	> 20000														
Weight (incl. standard adapter plate)	m	kg	10.3														
		lb _m	23														
Operating noise (at reference ratio and reference speed – ratio-specific values available in cymex [®])	L_{PA}	dB(A)	≤ 68														
		°C	+90														
Max. permitted housing temperature	F	°C	194														
		°C	0 to +40														
Ambient temperature	F	°C	32 to 104														
		°C	32 to 104														
Lubrication			Lubricated for life														
Direction of rotation			In- and output opposite direction														
Protection class			IP 65														
Metal bellows coupling (recommended product type – validate sizing with cymex [®])			BC2 - 00300AA - 032.000 - X														
Bore diameter of coupling on the application side		mm	X = 024.000 - 060.000														
Mass moment of inertia (relates to the drive)	C	14	J_1	kgcm ²	0.28	0.23	0.24	0.23	0.21	0.2	0.19	0.18	0.19	0.18	0.18	0.18	0.18
				10 ⁻³ in.lb.s ²	0.25	0.2	0.21	0.2	0.19	0.18	0.17	0.16	0.17	0.16	0.16	0.16	0.16
Clamping hub diameter [mm]	E	19	J_1	kgcm ²	0.72	0.63	0.68	0.68	0.63	0.63	0.63	0.63	0.63	0.63	0.63	0.63	
				10 ⁻³ in.lb.s ²	0.64	0.56	0.6	0.6	0.56	0.56	0.56	0.56	0.56	0.56	0.56	0.56	0.56

Please use our sizing software cymex[®] for a detailed sizing – www.wittenstein-cymex.com
Please contact us for optimum sizing at S1 conditions (Continuous operation).

- ^{a)} At max. 10 % F_{2QMax}
- ^{b)} Valid for standard clamping hub diameter
- ^{c)} Refers to center of the output shaft or flange
- ^{d)} Please reduce input speed at higher ambient temperatures
- ^{e)} Smooth shaft

View A

Motor shaft diameter [mm]

3-stage

up to 14/19⁴⁾
(C⁵⁾/E) clamping
hub diameter

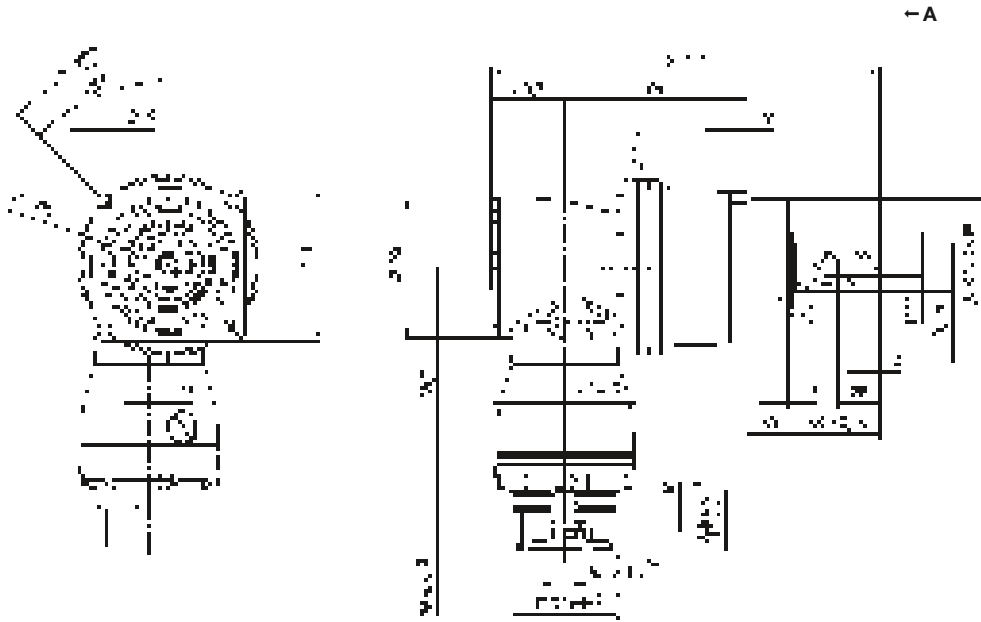

Hypoid gearboxes

SPK

Other output variants

Shaft with key



Splined shaft (DIN 5480)

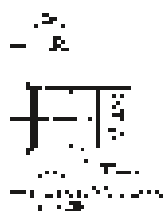

Shaft mounted

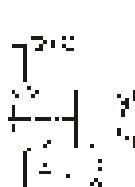

See technical data sheet for available clamping hub diameters (mass moment of inertia). Dimensions available on request.

Non-tolerated dimensions are nominal dimensions

- ¹⁾ Check motor shaft fit
- ²⁾ Min./Max. permissible motor shaft length. Longer motor shafts are possible, please contact alpha.
- ³⁾ The dimensions depend on the motor
- ⁴⁾ Smaller motor shaft diameter is compensated by a bushing with a minimum thickness of 1 mm
- ⁵⁾ Standard clamping hub diameter

SPK+ 140 MF 2-stage

			2-stage											
Ratio	<i>i</i>		12	16	20	25	28	35	40	50	70	100		
Max. torque ^{a) b) e)}	T_{2a}	Nm	816	816	1020	1020	825	825	500	625	625	720		
		in.lb	7222	7222	9028	9028	7302	7302	4425	5532	5532	6373		
Max. acceleration torque ^{b) e)} (max. 1000 cycles per hour)	T_{2B}	Nm	680	680	792	792	792	792	500	625	792	636		
		in.lb	6019	6019	7010	7010	7010	7010	4425	5532	7010	5629		
Nominal torque (at n_n)	T_{2N}	Nm	360	360	360	360	360	360	320	360	360	220		
		in.lb	3186	3186	3186	3186	3186	3186	2832	3186	3186	1947		
Emergency stop torque ^{a) b) e)} (permitted 1000 times during the service life of the gearbox)	T_{2Not}	Nm	880	1040	1300	1300	1350	1350	1000	1250	1350	1250		
		in.lb	7789	9205	11506	11506	11949	11949	8851	11064	11949	11064		
Permitted average input speed (at T_{2a} and 20 °C ambient temperature) ^{d)}	n_{1N}	n_{1T}	1900	2300	2300	2600	2300	2300	2300	2300	2300	2300		
Max. input speed	n_{1Max}	rpm	5500	5500	5500	5500	5500	5500	5500	5500	5500	5500		
Mean no load running torque ^{b)} (at $n_1 = 3000$ rpm and 20 °C gearbox temperature)	T_{012}	Nm	4	3.7	3.6	2.8	3.5	3.9	3.1	3.1	3.1	3.1		
		in.lb	35	33	32	25	31	35	27	27	27	27		
Max. backlash	j_t	arcmin	Standard ≤ 4 / Reduced ≤ 2											
Torsional rigidity ^{b)}	C_{t21}	Nm/arcmin	53	53	53	53	53	53	53	53	53	53		
		in.lb/arcmin	469	469	469	469	469	469	469	469	469	469		
Max. axial force ^{c)}	F_{2AMax}	N	9870											
		lb _f	2221											
Max. lateral force ^{c)}	F_{2QMax}	N	9450											
		lb _f	2126											
Max. tilting moment	M_{2KMax}	Nm	952											
		in.lb	8426											
Efficiency at full load	η	%	94											
Service life	L_h	h	> 20000											
Weight (incl. standard adapter plate)	m	kg	20											
		lb _m	44											
Operating noise (at reference ratio and reference speed – ratio-specific values available in cymex [®])	L_{PA}	dB(A)	≤ 68											
		°C	+90											
Max. permitted housing temperature		F	194											
		°C	0 to +40											
Ambient temperature		F	32 to 104											
Lubrication			Lubricated for life											
Direction of rotation			In- and output opposite direction											
Protection class			IP 65											
Metal bellows coupling (recommended product type – validate sizing with cymex [®])			BC2 - 00800AA - 040.000 - X											
Bore diameter of coupling on the application side		mm	X = 040.000 - 075.000											
Mass moment of inertia (relates to the drive)	H	28	J_1	kgcm ²	4.68	3.82	3.75	3.31	3.68	2.97	2.8	2.79	2.78	2.77
				10 ⁻³ in.lb.s ²	4.14	3.38	3.32	2.93	3.26	2.63	2.48	2.47	2.46	2.45
Clamping hub diameter [mm]	K	38	J_1	kgcm ²	11.8	11	10.9	10.5	10.9	10.1	9.96	9.95	9.94	9.94
				10 ⁻³ in.lb.s ²	10.44	9.74	9.65	9.29	9.65	8.94	8.81	8.81	8.8	8.8

Please use our sizing software cymex[®] for a detailed sizing – www.wittenstein-cymex.com
Please contact us for optimum sizing at S1 conditions (Continuous operation).

- ^{a)} At max. 10 % F_{2QMax}
- ^{b)} Valid for standard clamping hub diameter
- ^{c)} Refers to center of the output shaft or flange
- ^{d)} Please reduce input speed at higher ambient temperatures
- ^{e)} Smooth shaft

View A

Motor shaft diameter [mm]

2-stage

up to 28/38⁴⁾
(H⁵⁾/K) clamping
hub diameter

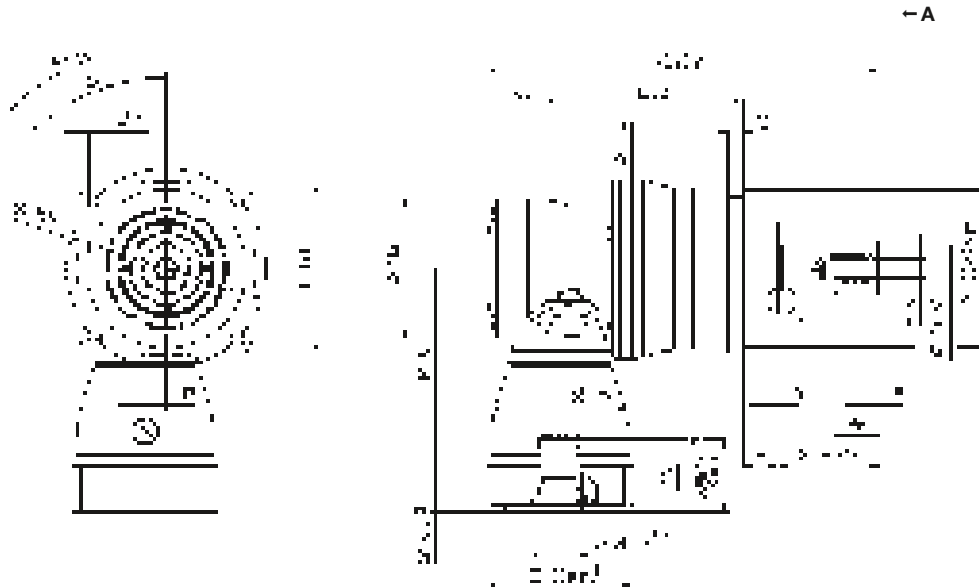

Hypoid gearboxes

SPK

Other output variants

Shaft with key



Splined shaft (DIN 5480)



Shaft mounted

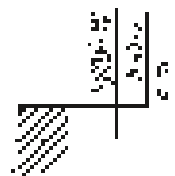
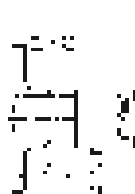

See technical data sheet for available clamping hub diameters (mass moment of inertia). Dimensions available on request.

- Non-tolerated dimensions are nominal dimensions
- ¹⁾ Check motor shaft fit
- ²⁾ Min./Max. permissible motor shaft length. Longer motor shafts are possible, please contact alpha.
- ³⁾ The dimensions depend on the motor
- ⁴⁾ Smaller motor shaft diameter is compensated by a bushing with a minimum thickness of 1 mm
- ⁵⁾ Standard clamping hub diameter

SPK+ 140 MF 3-stage

			3-stage														
Ratio	<i>i</i>		64	84	100	125	140	175	200	250	280	350	400	500	700	1000	
Max. torque ^{a) b) e)}	T_{2a}	Nm	816	816	1020	1020	1020	1020	1020	1020	825	825	500	625	825	720	
		in.lb	7222	7222	9028	9028	9028	9028	9028	9028	9028	7302	7302	4425	5532	7302	6373
Max. acceleration torque ^{b) e)} (max. 1000 cycles per hour)	T_{2B}	Nm	680	680	792	792	792	792	792	792	792	792	500	625	792	636	
		in.lb	6019	6019	7010	7010	7010	7010	7010	7010	7010	7010	7010	4425	5532	7010	5629
Nominal torque (at n_N)	T_{2N}	Nm	360	360	360	360	360	360	360	360	360	360	320	360	360	220	
		in.lb	3186	3186	3186	3186	3186	3186	3186	3186	3186	3186	3186	2832	3186	3186	1947
Emergency stop torque ^{a) b) e)} (permitted 1000 times during the service life of the gearbox)	T_{2Not}	Nm	1040	880	1300	1300	1300	1300	1300	1300	1300	1350	1350	1000	1250	1350	1250
		in.lb	9205	7789	11506	11506	11506	11506	11506	11506	11506	11949	11949	8851	11064	11949	11064
Permitted average input speed (at T_{2a} and 20 °C ambient temperature) ^{d)}	n_{1N}	n_{1T}	3100	3100	3100	3100	3100	3100	3100	3500	3100	3500	4200	4200	4200	4200	
Max. input speed	n_{1Max}	rpm	4500	4500	4500	4500	4500	4500	4500	4500	4500	4500	4500	4500	4500	4500	
Mean no load running torque ^{b)} (at $n_1 = 3000$ rpm and 20 °C gearbox temperature)	T_{012}	Nm	0.7	0.4	0.6	0.5	0.5	0.4	0.3	0.3	0.3	0.3	0.3	0.3	0.3	0.3	0.3
		in.lb	6	4	5	4	4	4	3	3	3	3	3	3	3	3	3
Max. backlash	j_t	arcmin	Standard ≤ 4 / Reduced ≤ 2														
Torsional rigidity ^{b)}	C_{t21}	Nm/arcmin	53	53	53	53	53	53	53	53	53	53	53	53	53	53	
		in.lb/arcmin	469	469	469	469	469	469	469	469	469	469	469	469	469	469	469
Max. axial force ^{c)}	F_{2AMax}	N	9870														
		lb _f	2221														
Max. lateral force ^{c)}	F_{2QMax}	N	9450														
		lb _f	2126														
Max. tilting moment	M_{2KMax}	Nm	952														
		in.lb	8426														
Efficiency at full load	η	%	92														
Service life	L_h	h	> 20000														
Weight (incl. standard adapter plate)	m	kg	20.7														
		lb _m	46														
Operating noise (at reference ratio and reference speed – ratio-specific values available in cymex [®])	L_{PA}	dB(A)	≤ 68														
		°C	+90														
Max. permitted housing temperature	F	°C	194														
		°C	0 to +40														
Ambient temperature	F	°C	32 to 104														
		°C	32 to 104														
Lubrication			Lubricated for life														
Direction of rotation			In- and output opposite direction														
Protection class			IP 65														
Metal bellows coupling (recommended product type – validate sizing with cymex [®])			BC2 - 00800AA - 040.000 - X														
		mm	X = 040.000 - 075.000														
Bore diameter of coupling on the application side			X = 040.000 - 075.000														
		mm	X = 040.000 - 075.000														
Mass moment of inertia (relates to the drive)	E 19	J_1	kgcm ²	1.01	0.76	0.88	0.85	0.76	0.75	0.7	0.69	0.7	0.69	0.69	0.69	0.69	0.69
			10 ⁻³ in.lb.s ²	0.89	0.67	0.78	0.75	0.67	0.66	0.62	0.61	0.62	0.61	0.61	0.61	0.61	0.61
Clamping hub diameter [mm]	G 24	J_1	kgcm ²	2.57	2.32	2.44	2.42	2.32	2.31	2.26	2.25	2.26	2.25	2.25	2.25	2.25	2.25
			10 ⁻³ in.lb.s ²	2.27	2.05	2.16	2.14	2.05	2.04	2	1.99	2	1.99	1.99	1.99	1.99	1.99

Please use our sizing software cymex[®] for a detailed sizing – www.wittenstein-cymex.com
Please contact us for optimum sizing at S1 conditions (Continuous operation).

- ^{a)} At max. 10 % F_{2QMax}
- ^{b)} Valid for standard clamping hub diameter
- ^{c)} Refers to center of the output shaft or flange
- ^{d)} Please reduce input speed at higher ambient temperatures
- ^{e)} Smooth shaft

View A

Motor shaft diameter [mm]

3-stage

up to 19/24⁴⁾
(E⁵⁾/G) clamping
hub diameter

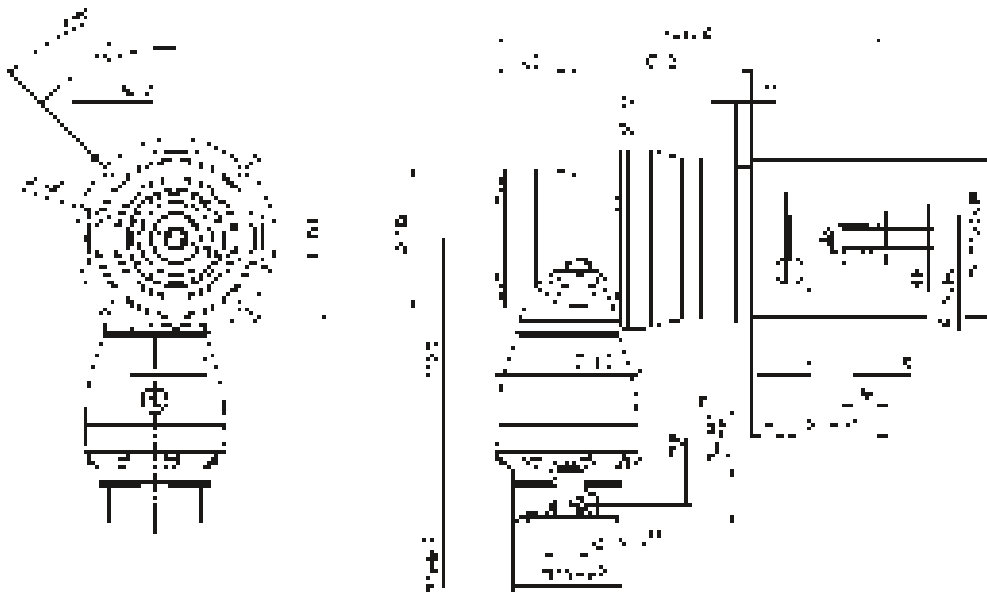

Hypoid gearboxes

SPK

Other output variants

Shaft with key



Splined shaft (DIN 5480)

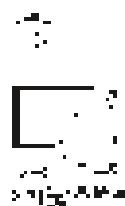

Shaft mounted

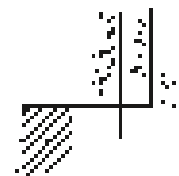

See technical data sheet for available clamping hub diameters (mass moment of inertia). Dimensions available on request.

Non-tolerated dimensions are nominal dimensions

- ¹⁾ Check motor shaft fit
- ²⁾ Min./Max. permissible motor shaft length. Longer motor shafts are possible, please contact alpha.
- ³⁾ The dimensions depend on the motor
- ⁴⁾ Smaller motor shaft diameter is compensated by a bushing with a minimum thickness of 1 mm
- ⁵⁾ Standard clamping hub diameter

SPK+ 180 MF 2-stage

			2-stage											
Ratio	<i>i</i>		12	16	20	25	28	35	40	50	70	100		
Max. torque ^{a) b) e)}	T_{2a}	Nm	1440	1440	1800	1800	1936	1936	840	1050	1470	1552		
		in.lb	12745	12745	15931	15931	17135	17135	7435	9293	13011	13736		
Max. acceleration torque ^{b) e)} (max. 1000 cycles per hour)	T_{2B}	Nm	1200	1200	1452	1452	1452	1452	840	1050	1452	1164		
		in.lb	10621	10621	12851	12851	12851	12851	7435	9293	12851	10302		
Nominal torque (at n_n)	T_{2N}	Nm	750	750	750	750	750	750	640	750	750	750		
		in.lb	6638	6638	6638	6638	6638	6638	5665	6638	6638	6638		
Emergency stop torque ^{a) b) e)} (permitted 1000 times during the service life of the gearbox)	T_{2Not}	Nm	1600	2000	2500	2500	2750	2750	1600	2000	2750	2750		
		in.lb	14161	17702	22127	22127	24340	24340	14161	17702	24340	24340		
Permitted average input speed (at T_{2a} and 20 °C ambient temperature) ^{d)}	n_{1N}	n_{1T}	1600	1900	1900	2100	1900	2100	2100	2100	2100	2100		
Max. input speed	n_{1Max}	rpm	5000	5000	5000	5000	5000	5000	5000	5000	5000	5000		
Mean no load running torque ^{b)} (at $n_1 = 3000$ rpm and 20 °C gearbox temperature)	T_{012}	Nm	9	6.5	6.5	5.5	6	8	6	6	6	6		
		in.lb	80	58	58	49	53	71	53	53	53	53		
Max. backlash	j_t	arcmin	Standard ≤ 4 / Reduced ≤ 2											
Torsional rigidity ^{b)}	C_{t21}	Nm/arcmin	175	175	175	175	175	175	175	175	175	175		
		in.lb/arcmin	1549	1549	1549	1549	1549	1549	1549	1549	1549	1549		
Max. axial force ^{c)}	F_{2AMax}	N	15570											
		lb _f	3503											
Max. lateral force ^{c)}	F_{2QMax}	N	15400											
		lb _f	3465											
Max. tilting moment	M_{2KMax}	Nm	1600											
		in.lb	14161											
Efficiency at full load	η	%	94											
Service life	L_h	h	> 20000											
Weight (incl. standard adapter plate)	m	kg	45											
		lb _m	99											
Operating noise (at reference ratio and reference speed – ratio-specific values available in cymex [®])	L_{PA}	dB(A)	≤ 70											
Max. permitted housing temperature		°C	+90											
		F	194											
Ambient temperature		°C	0 to +40											
		F	32 to 104											
Lubrication			Lubricated for life											
Direction of rotation			In- and output opposite direction											
Protection class			IP 65											
Metal bellows coupling (recommended product type – validate sizing with cymex [®])			BC2 - 01500AA - 055.000 - X											
Bore diameter of coupling on the application side		mm	X = 050.000 - 080.000											
Mass moment of inertia (relates to the drive) Clamping hub diameter [mm]	K	38	J_1	kgcm ²	24.7	19.5	19	16.3	18.6	14	12.9	12.8	12.7	12.7
				10 ⁻³ in.lb.s ²	21.86	17.26	16.82	14.43	16.46	12.39	11.42	11.33	11.24	11.24

Please use our sizing software cymex[®] for a detailed sizing – www.wittenstein-cymex.com
Please contact us for optimum sizing at S1 conditions (Continuous operation).

- ^{a)} At max. 10 % F_{2QMax}
- ^{b)} Valid for standard clamping hub diameter
- ^{c)} Refers to center of the output shaft or flange
- ^{d)} Please reduce input speed at higher ambient temperatures
- ^{e)} Smooth shaft

View A

Motor shaft diameter [mm]

2-stage

up to 38⁴⁾ (K)⁵⁾
clamping hub diameter

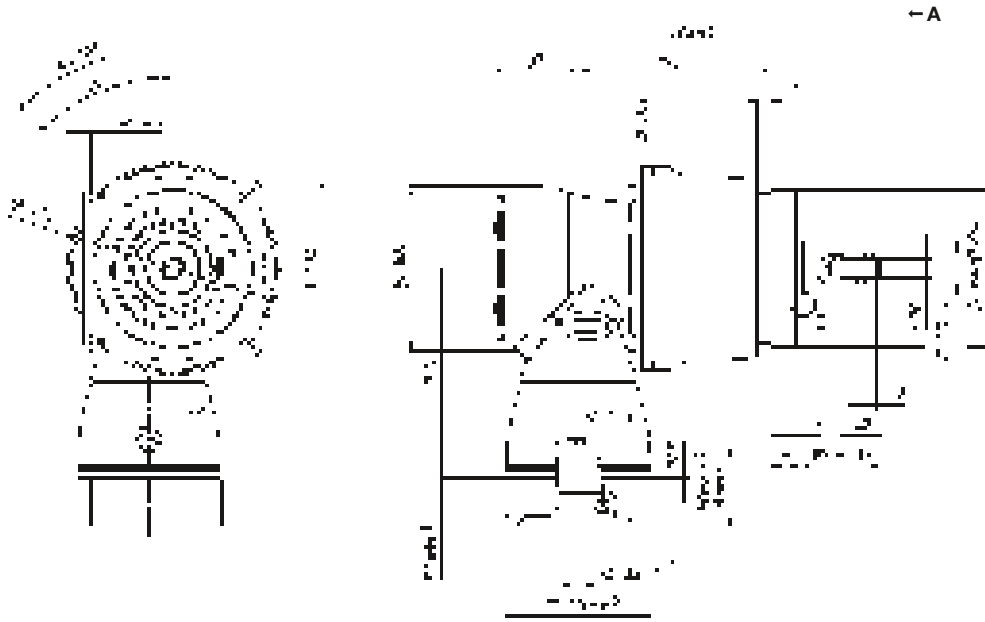

Hypoid gearboxes

SPK

Other output variants

Shaft with key



Splined shaft (DIN 5480)



Shaft mounted



See technical data sheet for available clamping hub diameters (mass moment of inertia). Dimensions available on request.

- Non-tolerated dimensions are nominal dimensions
- ¹⁾ Check motor shaft fit
- ²⁾ Min./Max. permissible motor shaft length. Longer motor shafts are possible, please contact alpha.
- ³⁾ The dimensions depend on the motor
- ⁴⁾ Smaller motor shaft diameter is compensated by a bushing with a minimum thickness of 1 mm
- ⁵⁾ Standard clamping hub diameter

SPK+ 180 MF 3-stage

				3-stage														
Ratio	<i>i</i>			64	84	100	125	140	175	200	250	280	350	400	500	700	1000	
Max. torque ^{a) b) e)}	T_{2a}	<i>Nm</i>		1440	1440	1800	1800	1800	1800	1800	1800	1936	1936	840	1050	1470	1552	
		<i>in.lb</i>		12745	12745	15931	15931	15931	15931	15931	15931	15931	17135	17135	7435	9293	13011	13736
Max. acceleration torque ^{b) e)} (max. 1000 cycles per hour)	T_{2B}	<i>Nm</i>		1200	1200	1452	1452	1452	1452	1452	1452	1452	1452	840	1050	1452	1164	
		<i>in.lb</i>		10621	10621	12851	12851	12851	12851	12851	12851	12851	12851	12851	7435	9293	12851	10302
Nominal torque (at n_n)	T_{2N}	<i>Nm</i>		750	750	750	750	750	750	750	750	750	750	640	750	750	750	
		<i>in.lb</i>		6638	6638	6638	6638	6638	6638	6638	6638	6638	6638	6638	5665	6638	6638	6638
Emergency stop torque ^{a) b) e)} (permitted 1000 times during the service life of the gearbox)	T_{2Not}	<i>Nm</i>		2000	1600	2500	2500	2500	2500	2500	2500	2500	2750	2750	1600	2000	2750	2750
		<i>in.lb</i>		17702	14161	22127	22127	22127	22127	22127	22127	22127	22127	24340	24340	14161	17702	24340
Permitted average input speed (at T_{2a} and 20 °C ambient temperature) ^{d)}	n_{1N}	n_{1T}		2900	2900	2900	2900	2900	2900	2900	3200	2900	3200	3900	3900	3900	3900	
Max. input speed	n_{1Max}	<i>rpm</i>		4500	4500	4500	4500	4500	4500	4500	4500	4500	4500	4500	4500	4500	4500	
Mean no load running torque ^{b)} (at $n_1 = 3000$ rpm and 20 °C gearbox temperature)	T_{012}	<i>Nm</i>		1	0.5	0.8	0.6	0.6	0.5	0.5	0.4	0.5	0.4	0.4	0.4	0.4	0.4	
		<i>in.lb</i>		9	4	7	5	5	4	4	4	4	4	4	4	4	4	4
Max. backlash	j_t	<i>arcmin</i>		Standard ≤ 4 / Reduced ≤ 2														
Torsional rigidity ^{b)}	C_{t21}	<i>Nm/arcmin</i>		175	175	175	175	175	175	175	175	175	175	175	175	175	175	
		<i>in.lb/arcmin</i>		1549	1549	1549	1549	1549	1549	1549	1549	1549	1549	1549	1549	1549	1549	1549
Max. axial force ^{c)}	F_{2AMax}	<i>N</i>		15570														
		<i>lb_f</i>		3503														
Max. lateral force ^{c)}	F_{2QMax}	<i>N</i>		15400														
		<i>lb_f</i>		3465														
Max. tilting moment	M_{2KMax}	<i>Nm</i>		1600														
		<i>in.lb</i>		14161														
Efficiency at full load	η	%		92														
Service life	L_h	<i>h</i>		> 20000														
Weight (incl. standard adapter plate)	<i>m</i>	<i>kg</i>		47.4														
		<i>lb_m</i>		105														
Operating noise (at reference ratio and reference speed – ratio-specific values available in cymex [®])	L_{PA}	<i>dB(A)</i>		≤ 70														
Max. permitted housing temperature		°C		+90														
		<i>F</i>		194														
Ambient temperature		°C		0 to +40														
		<i>F</i>		32 to 104														
Lubrication				Lubricated for life														
Direction of rotation				In- and output opposite direction														
Protection class				IP 65														
Metal bellows coupling (recommended product type – validate sizing with cymex [®])				BC2 - 01500AA - 055.000 - X														
Bore diameter of coupling on the application side		<i>mm</i>		X = 050.000 - 080.000														
Mass moment of inertia (relates to the drive)	G 24	J_1	<i>kgcm²</i>	3.97	2.82	3.36	3.22	2.82	2.75	2.5	2.47	2.5	2.44	2.42	2.42	2.42	2.42	
			<i>10⁻³ in.lb.s²</i>	3.51	2.5	2.97	2.85	2.5	2.43	2.21	2.19	2.21	2.16	2.14	2.14	2.14	2.14	
Clamping hub diameter [mm]	K 38	J_1	<i>kgcm²</i>	10.9	9.74	10.3	10.1	9.74	9.66	9.41	9.38	9.41	9.38	9.33	9.33	9.33	9.33	
			<i>10⁻³ in.lb.s²</i>	9.65	8.62	9.12	8.94	8.62	8.55	8.33	8.3	8.33	8.3	8.26	8.26	8.26	8.26	

Please use our sizing software cymex[®] for a detailed sizing – www.wittenstein-cymex.com
Please contact us for optimum sizing at S1 conditions (Continuous operation).

- ^{a)} At max. 10 % F_{2QMax}
- ^{b)} Valid for standard clamping hub diameter
- ^{c)} Refers to center of the output shaft or flange
- ^{d)} Please reduce input speed at higher ambient temperatures
- ^{e)} Smooth shaft

View A

Motor shaft diameter [mm]

3-stage

up to 24/38⁴⁾
(G⁵⁾/K) clamping
hub diameter

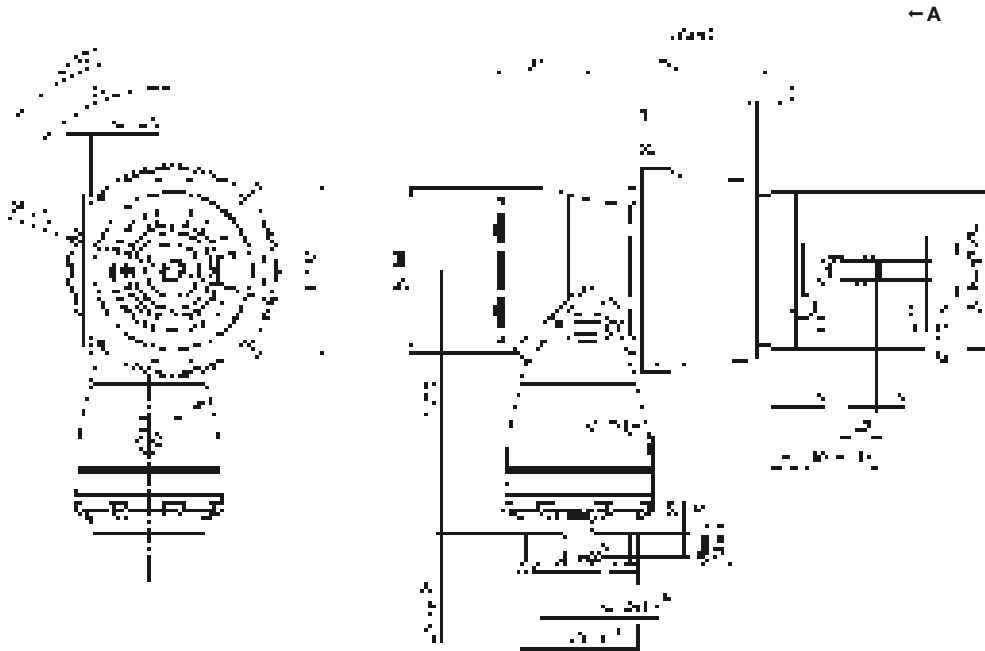

Hypoid gearboxes

SPK

Other output variants

Shaft with key



Splined shaft (DIN 5480)



Shaft mounted

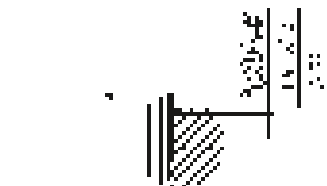
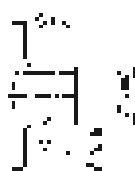

See technical data sheet for available clamping hub diameters (mass moment of inertia). Dimensions available on request.

- Non-tolerated dimensions are nominal dimensions
- ¹⁾ Check motor shaft fit
- ²⁾ Min./Max. permissible motor shaft length. Longer motor shafts are possible, please contact alpha.
- ³⁾ The dimensions depend on the motor
- ⁴⁾ Smaller motor shaft diameter is compensated by a bushing with a minimum thickness of 1 mm
- ⁵⁾ Standard clamping hub diameter

SPK+ 210 MF 2-stage

			2-stage											
Ratio	<i>i</i>		12	16	20	25	28	35	40	50	70	100		
Max. torque ^{a) b) e)}	T_{2a}	Nm	3072	3072	3840	3840	3840	3840	1880	2350	3290	2800		
		in.lb	27190	27190	33987	33987	33987	33987	16640	20799	29119	24782		
Max. acceleration torque ^{b) e)} (max. 1000 cycles per hour)	T_{2B}	Nm	2560	2560	3000	3000	2880	2880	1880	2350	2880	2280		
		in.lb	22658	22658	26552	26552	25490	25490	16640	20799	25490	20180		
Nominal torque (at n_n)	T_{2N}	Nm	1500	1500	1500	1500	1400	1500	1400	1500	1400	1000		
		in.lb	13276	13276	13276	13276	12391	13276	12391	13276	12391	8851		
Emergency stop torque ^{a) b) e)} (permitted 1000 times during the service life of the gearbox)	T_{2Not}	Nm	3600	4200	5250	5250	5900	5900	3600	4500	5900	5900		
		in.lb	31863	37173	46467	46467	52220	52220	31863	39829	52220	52220		
Permitted average input speed (at T_{2a} and 20 °C ambient temperature) ^{d)}	n_{1N}	n_{1T}	1500	1700	1700	1900	1700	1900	1700	1700	1700	1700		
Max. input speed	n_{1Max}	rpm	4500	4500	4500	4500	4500	4500	4500	4500	4500	4500		
Mean no load running torque ^{b)} (at $n_1 = 3000$ rpm and 20 °C gearbox temperature)	T_{012}	Nm	18.5	17	15	13	14	12	15	15	14	13		
		in.lb	164	150	133	115	124	106	133	133	124	115		
Max. backlash	j_t	arcmin	Standard ≤ 4 / Reduced ≤ 2											
Torsional rigidity ^{b)}	C_{t21}	Nm/arcmin	300	300	300	300	300	300	300	300	300	300		
		in.lb/arcmin	2655	2655	2655	2655	2655	2655	2655	2655	2655	2655		
Max. axial force ^{c)}	F_{2AMax}	N	30000											
		lb _f	6750											
Max. lateral force ^{c)}	F_{2QMax}	N	21000											
		lb _f	4725											
Max. tilting moment	M_{2KMax}	Nm	3100											
		in.lb	27437											
Efficiency at full load	η	%	94											
Service life	L_h	h	> 20000											
Weight (incl. standard adapter plate)	m	kg	82											
		lb _m	181											
Operating noise (at reference ratio and reference speed – ratio-specific values available in cymex [®])	L_{PA}	dB(A)	≤ 71											
		°C	+90											
Max. permitted housing temperature		F	194											
		°C	0 to +40											
Ambient temperature		F	32 to 104											
Lubrication			Lubricated for life											
Direction of rotation			In- and output opposite direction											
Protection class			IP 65											
Metal bellows coupling (recommended product type – validate sizing with cymex [®])			BC2 - 04000AA - 075.000 - X											
Bore diameter of coupling on the application side		mm	X = 050.000 - 090.000											
Mass moment of inertia (relates to the drive) Clamping hub diameter [mm]	M	48	J_1	kgcm ²	78.8	54.6	53	43.4	51.5	42.2	30.2	30	29.8	29.8
				10 ⁻³ in.lb.s ²	69.74	48.32	46.91	38.41	45.58	37.35	26.73	26.55	26.37	26.37

Please use our sizing software cymex[®] for a detailed sizing – www.wittenstein-cymex.com
Please contact us for optimum sizing at S1 conditions (Continuous operation).

- ^{a)} At max. 10 % F_{2QMax}
- ^{b)} Valid for standard clamping hub diameter
- ^{c)} Refers to center of the output shaft or flange
- ^{d)} Please reduce input speed at higher ambient temperatures
- ^{e)} Smooth shaft

Motor shaft diameter [mm]

2-stage

up to 48⁴⁾ (M)⁵⁾
clamping hub diameter

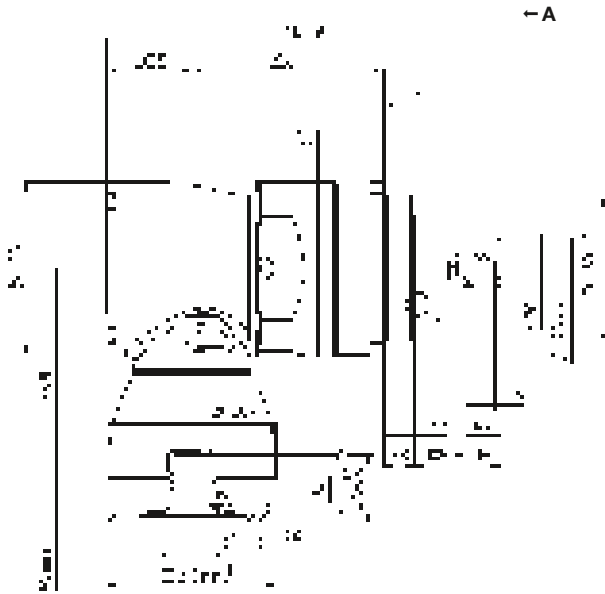
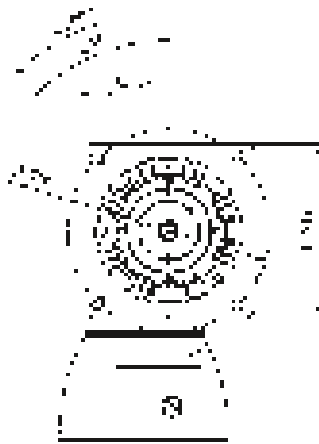

Hypoid gearboxes

SPK

Other output variants

Shaft with key

Splined shaft (DIN 5480)

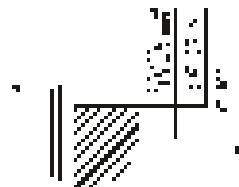

See technical data sheet for available clamping hub diameters (mass moment of inertia). Dimensions available on request.

Non-tolerated dimensions are nominal dimensions
¹⁾ Check motor shaft fit

²⁾ Min./Max. permissible motor shaft length. Longer motor shafts are possible, please contact alpha.

³⁾ The dimensions depend on the motor

⁴⁾ Smaller motor shaft diameter is compensated by a bushing with a minimum thickness of 1 mm

⁵⁾ Standard clamping hub diameter

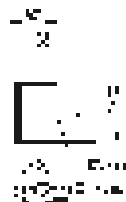

SPK+ 210 MF 3-stage

			3-stage														
Ratio	<i>i</i>		64	84	100	125	140	175	200	250	280	350	400	500	700	1000	
Max. torque ^{a) b) e)}	T_{2a}	Nm	3072	3072	3840	3840	3840	3840	3840	3840	3840	3840	1880	2350	3290	2800	
		in.lb	27190	27190	33987	33987	33987	33987	33987	33987	33987	33987	33987	16640	20799	29119	24782
Max. acceleration torque ^{b) e)} (max. 1000 cycles per hour)	T_{2B}	Nm	2560	2560	3000	3000	3000	3000	3000	3000	2880	2880	1880	2350	2880	2280	
		in.lb	22658	22658	26552	26552	26552	26552	26552	26552	25490	25490	16640	20799	25490	20180	
Nominal torque (at n_n)	T_{2N}	Nm	1500	1500	1500	1500	1500	1500	1500	1500	1400	1400	1500	1500	1400	1000	
		in.lb	13276	13276	13276	13276	13276	13276	13276	13276	12391	12391	13276	13276	12391	8851	
Emergency stop torque ^{a) b) e)} (permitted 1000 times during the service life of the gearbox)	T_{2Not}	Nm	4200	3600	5250	5250	5250	5250	5250	5250	5900	5900	3600	4500	5900	5900	
		in.lb	37173	31863	46467	46467	46467	46467	46467	46467	52220	52220	31863	39829	52220	52220	
Permitted average input speed (at T_{2a} and 20 °C ambient temperature) ^{d)}	n_{1N}	n_{1T}	2700	2700	2700	2700	2700	2700	2700	2900	2700	2900	3400	3400	3400	3400	
Max. input speed	n_{1Max}	rpm	4000	4000	4000	4000	4000	4000	4000	4000	4000	4000	4000	4000	4000	4000	
Mean no load running torque ^{b)} (at $n_1 = 3000$ rpm and 20 °C gearbox temperature)	T_{012}	Nm	2.4	1.2	1.9	1.7	1.3	1.3	1	1	1	1	1	1	1	1	
		in.lb	21	11	17	15	12	12	9	9	9	9	9	9	9	9	
Max. backlash	j_t	arcmin	Standard ≤ 4 / Reduced ≤ 2														
Torsional rigidity ^{b)}	C_{t21}	Nm/arcmin	300	300	300	300	300	300	300	300	300	300	300	300	300	300	
		in.lb/arcmin	2655	2655	2655	2655	2655	2655	2655	2655	2655	2655	2655	2655	2655	2655	
Max. axial force ^{c)}	F_{2AMax}	N	30000														
		lb _f	6750														
Max. lateral force ^{c)}	F_{2QMax}	N	21000														
		lb _f	4725														
Max. tilting moment	M_{2KMax}	Nm	3100														
		in.lb	27437														
Efficiency at full load	η	%	92														
Service life	L_h	h	> 20000														
Weight (incl. standard adapter plate)	m	kg	86														
		lb _m	190														
Operating noise (at reference ratio and reference speed – ratio-specific values available in cymex [®])	L_{PA}	dB(A)	≤ 71														
Max. permitted housing temperature		°C	+90														
		F	194														
Ambient temperature		°C	0 to +40														
		F	32 to 104														
Lubrication			Lubricated for life														
Direction of rotation			In- and output opposite direction														
Protection class			IP 65														
Metal bellows coupling (recommended product type – validate sizing with cymex [®])			BC2 - 04000AA - 075.000 - X														
Bore diameter of coupling on the application side		mm	X = 050.000 - 090.000														
Mass moment of inertia (relates to the drive)	K	38	J_1	kgcm ²	14	10.9	12.3	12	10.9	10.7	10.1	10	10.1	10	9.9	9.9	9.9
				10 ⁻³ in.lb.s ²	12.39	9.65	10.89	10.62	9.65	9.47	8.94	8.85	8.94	8.85	8.76	8.76	8.76
Clamping hub diameter [mm]	M	48	J_1	kgcm ²	28.7	25.6	27.1	26.7	26.7	25.6	24.8	24.7	24.8	24.7	24.6	24.6	24.6
				10 ⁻³ in.lb.s ²	25.4	22.66	23.98	23.63	23.63	22.66	21.95	21.86	21.95	21.86	21.77	21.77	21.77

Please use our sizing software cymex[®] for a detailed sizing – www.wittenstein-cymex.com
Please contact us for optimum sizing at S1 conditions (Continuous operation).

- ^{a)} At max. 10 % F_{2QMax}
- ^{b)} Valid for standard clamping hub diameter
- ^{c)} Refers to center of the output shaft or flange
- ^{d)} Please reduce input speed at higher ambient temperatures
- ^{e)} Smooth shaft

View A

Motor shaft diameter [mm]

3-stage

up to 38/48⁴⁾
(K⁵⁾/M) clamping
hub diameter

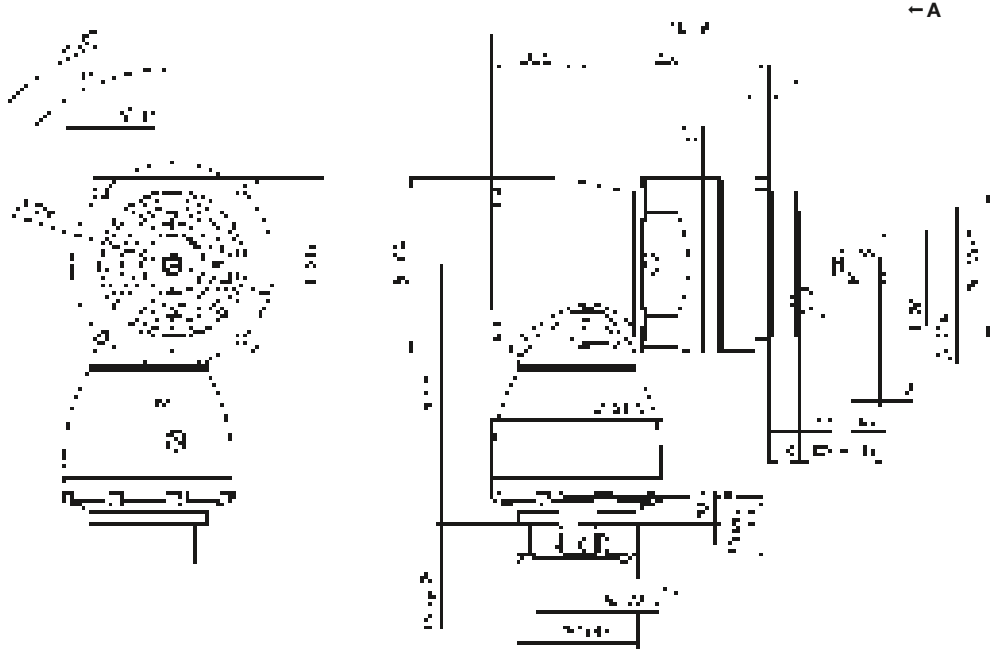

Hypoid gearboxes

SPK

Other output variants

Shaft with key

Splined shaft (DIN 5480)

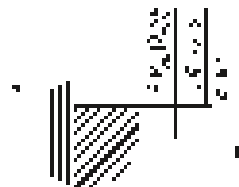
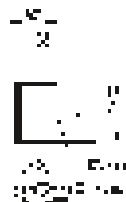

See technical data sheet for available clamping hub diameters (mass moment of inertia). Dimensions available on request.

Non-tolerated dimensions are nominal dimensions
¹⁾ Check motor shaft fit

²⁾ Min./Max. permissible motor shaft length. Longer motor shafts are possible, please contact alpha.

³⁾ The dimensions depend on the motor

⁴⁾ Smaller motor shaft diameter is compensated by a bushing with a minimum thickness of 1 mm

⁵⁾ Standard clamping hub diameter

SPK+ 240 MF 3-stage

			3-stage													
Ratio	<i>i</i>		48	64	100	125	140	175	200	250	280	350	400	500	700	1000
Max. torque ^{a) b) e)}	T_{2a}	Nm	5446	5446	5446	5700	5000	5700	4200	5250	5446	5700	5446	5700	5700	3642
		in.lb	48201	48201	48201	50450	44254	50450	37173	46467	48201	50450	48201	50450	50450	32235
Max. acceleration torque ^{b) e)} (max. 1000 cycles per hour)	T_{2B}	Nm	4800	4800	5400	5400	5000	5400	4200	5250	5400	5400	4400	5160	4730	3642
		in.lb	42484	42484	47794	47794	44254	47794	37173	46467	47794	47794	38944	45670	41864	32235
Nominal torque (at n_n)	T_{2N}	Nm	2500	2500	2500	2500	2500	2500	2500	2500	2500	2500	2500	2500	2300	1700
		in.lb	22127	22127	22127	22127	22127	22127	22127	22127	22127	22127	22127	22127	20357	15046
Emergency stop torque ^{a) b) e)} (permitted 1000 times during the service life of the gearbox)	T_{2Not}	Nm	6400	8000	8500	8500	8500	8500	8000	8500	8500	8500	8500	8500	8500	6850
		in.lb	56645	70806	75232	75232	75232	75232	70806	75232	75232	75232	75232	75232	75232	60628
Permitted average input speed (at T_{2a} and 20 °C ambient temperature) ^{d)}	n_{1N}	n_{1T}	1800	1900	1900	2100	1900	2100	2100	2100	2100	2100	2100	2100	2100	2100
Max. input speed	n_{1Max}	rpm	5000	5000	5000	5000	5000	5000	5000	5000	5000	5000	5000	5000	5000	5000
Mean no load running torque ^{b)} (at $n_1 = 3000$ rpm and 20 °C gearbox temperature)	T_{012}	Nm	11	8	7	7	8	8	7	6	6	6	6	6	6	6
		in.lb	97	71	62	62	71	71	62	53	53	53	53	53	53	53
Max. backlash	j_t	arcmin	Standard ≤ 5.5 / Reduced ≤ 3.5													
Torsional rigidity ^{b)}	C_{t21}	Nm/arcmin	510	510	510	510	510	510	510	510	510	510	510	510	510	510
		in.lb/arcmin	4514	4514	4514	4514	4514	4514	4514	4514	4514	4514	4514	4514	4514	4514
Max. axial force ^{c)}	F_{2AMax}	N	33000													
		lb _f	7425													
Max. lateral force ^{c)}	F_{2QMax}	N	30000													
		lb _f	6750													
Max. tilting moment	M_{2KMax}	Nm	5000													
		in.lb	44254													
Efficiency at full load	η	%	92													
Service life	L_h	h	> 20000													
Weight (incl. standard adapter plate)	m	kg	93													
		lb _m	206													
Operating noise (at reference ratio and reference speed – ratio-specific values available in cymex [®])	L_{PA}	dB(A)	≤ 71													
		°C	+90													
Max. permitted housing temperature		F	194													
		°C	0 to +40													
Ambient temperature		F	32 to 104													
Lubrication			Lubricated for life													
Direction of rotation			In- and output opposite direction													
Protection class			IP 65													
Metal bellows coupling (recommended product type – validate sizing with cymex [®])			BC2 - 06000AA - 085.000 - X													
		Bore diameter of coupling on the application side	mm	X = 060.000 - 140.000												
Mass moment of inertia (relates to the drive) Clamping hub diameter [mm]	K	38	J_1	kgcm ²	26.5	20	17	17	15	15	13	13	13	13	13	13
				10 ⁻³ in.lb.s ²	23.45	17.7	15.05	15.05	13.28	13.28	11.51	11.51	11.51	11.51	11.51	11.51

Please use our sizing software cymex[®] for a detailed sizing – www.wittenstein-cymex.com
Please contact us for optimum sizing at S1 conditions (Continuous operation).

- ^{a)} At max. 10 % F_{2QMax}
- ^{b)} Valid for standard clamping hub diameter
- ^{c)} Refers to center of the output shaft or flange
- ^{d)} Please reduce input speed at higher ambient temperatures
- ^{e)} Smooth shaft

View A

Motor shaft diameter [mm]

3-stage

up to 38⁴⁾ (K)⁵⁾
clamping hub diameter

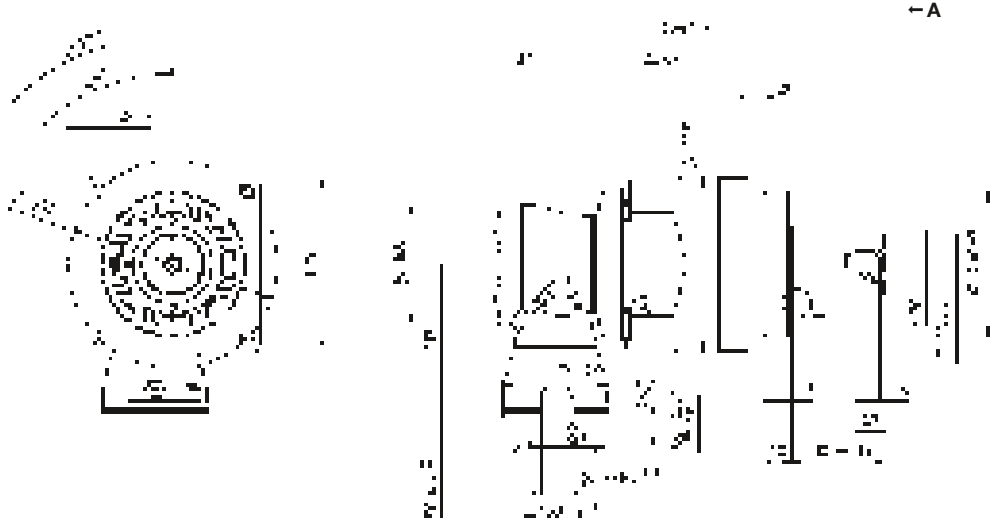

Hypoid gearboxes

SPK

Other output variants

Shaft with key

Splined shaft (DIN 5480)

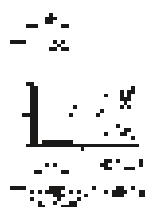

See technical data sheet for available clamping hub diameters (mass moment of inertia). Dimensions available on request.

Non-tolerated dimensions are nominal dimensions
¹⁾ Check motor shaft fit

²⁾ Min./Max. permissible motor shaft length. Longer motor shafts are possible, please contact alpha.

³⁾ The dimensions depend on the motor

⁴⁾ Smaller motor shaft diameter is compensated by a bushing with a minimum thickness of 1 mm

⁵⁾ Standard clamping hub diameter

SPK+ 240 MF 4-stage i=144-1000

			4-stage													
Ratio	<i>i</i>		144	192	256	300	375	420	500	560	600	700	800	875	1000	
Max. torque ^{a) b) e)}	T_{2a}	Nm	5446	5446	5446	5446	5700	5446	5446	5446	5446	5446	5446	5700	5446	
		in.lb	48201	48201	48201	48201	50450	48201	48201	48201	48201	48201	48201	48201	50450	48201
Max. acceleration torque ^{b) e)} (max. 1000 cycles per hour)	T_{2B}	Nm	4800	4800	4800	5400	5400	5400	5400	5400	5400	5400	5400	5400	5400	
		in.lb	42484	42484	42484	47794	47794	47794	47794	47794	47794	47794	47794	47794	47794	
Nominal torque (at n_n)	T_{2N}	Nm	2500	2500	2500	2500	2500	2500	2500	2500	2500	2500	2500	2500	2500	
		in.lb	22127	22127	22127	22127	22127	22127	22127	22127	22127	22127	22127	22127	22127	
Emergency stop torque ^{a) b) e)} (permitted 1000 times during the service life of the gearbox)	T_{2Not}	Nm	6400	6400	8000	8000	8500	8000	8500	8500	8000	8500	8500	8500	8500	
		in.lb	56645	56645	70806	70806	75232	70806	75232	75232	70806	75232	75232	75232	75232	
Permitted average input speed (at T_{2a} and 20 °C ambient temperature) ^{d)}	n_{1N}	n_{1T}	2700	2900	2900	2900	2900	2900	2900	2900	2900	2900	2900	2900	3200	
Max. input speed	n_{1Max}	rpm	4500	4500	4500	4500	4500	4500	4500	4500	4500	4500	4500	4500	4500	
Mean no load running torque ^{b)} (at $n_i = 3000$ rpm and 20 °C gearbox temperature)	T_{012}	Nm	3.2	2.3	1.6	1.3	0.7	0.9	0.9	0.8	0.7	0.7	0.6	0.6	0.5	
		in.lb	28	20	14	12	6	8	8	7	6	6	5	5	4	
Max. backlash	j_t	arcmin	Standard ≤ 5.5 / Reduced ≤ 3.5													
Torsional rigidity ^{b)}	C_{t21}	Nm/arcmin	510	510	510	510	510	510	510	510	510	510	510	510	510	
		in.lb/arcmin	4514	4514	4514	4514	4514	4514	4514	4514	4514	4514	4514	4514	4514	
Max. axial force ^{c)}	F_{2AMax}	N	33000													
		lb _f	7425													
Max. lateral force ^{c)}	F_{2QMax}	N	30000													
		lb _f	6750													
Max. tilting moment	M_{2KMax}	Nm	5000													
		in.lb	44254													
Efficiency at full load	η	%	90													
Service life	L_h	h	> 20000													
Weight (incl. standard adapter plate)	m	kg	96													
		lb _m	212													
Operating noise (at reference ratio and reference speed – ratio-specific values available in cymex [®])	L_{PA}	dB(A)	≤ 71													
		°C	+90													
Max. permitted housing temperature	F	°C	194													
		°C	0 to +40													
Ambient temperature	F	°C	32 to 104													
		°C	32 to 104													
Lubrication			Lubricated for life													
Direction of rotation			In- and output opposite direction													
Protection class			IP 65													
Metal bellows coupling (recommended product type – validate sizing with cymex [®])			BC2 - 06000AA - 085.000 - X													
		mm	X = 060.000 - 140.000													
Bore diameter of coupling on the application side			X = 060.000 - 140.000													
		mm	X = 060.000 - 140.000													
Mass moment of inertia (relates to the drive)	G 24	J_1	kgcm ²	5.96	4.3	3.9	3.32	3.31	2.8	3.18	2.8	2.49	2.73	2.49	2.73	2.46
			10 ⁻³ in.lb.s ²	5.27	3.81	3.45	2.94	2.93	2.48	2.81	2.48	2.2	2.42	2.2	2.42	2.18
Clamping hub diameter [mm]	K 38	J_1	kgcm ²	12.87	11.19	10.81	10.23	10.22	9.72	10.09	9.71	9.4	9.65	9.4	9.65	9.37
			10 ⁻³ in.lb.s ²	11.39	9.9	9.57	9.05	9.04	8.6	8.93	8.59	8.32	8.54	8.32	8.54	8.29

Please use our sizing software cymex[®] for a detailed sizing – www.wittenstein-cymex.com
Please contact us for optimum sizing at S1 conditions (Continuous operation).

- ^{a)} At max. 10 % F_{2QMax}
- ^{b)} Valid for standard clamping hub diameter
- ^{c)} Refers to center of the output shaft or flange
- ^{d)} Please reduce input speed at higher ambient temperatures
- ^{e)} Smooth shaft

View A

Motor shaft diameter [mm]

4-stage

up to 24/38⁴⁾
(G⁵⁾/K) clamping
hub diameter

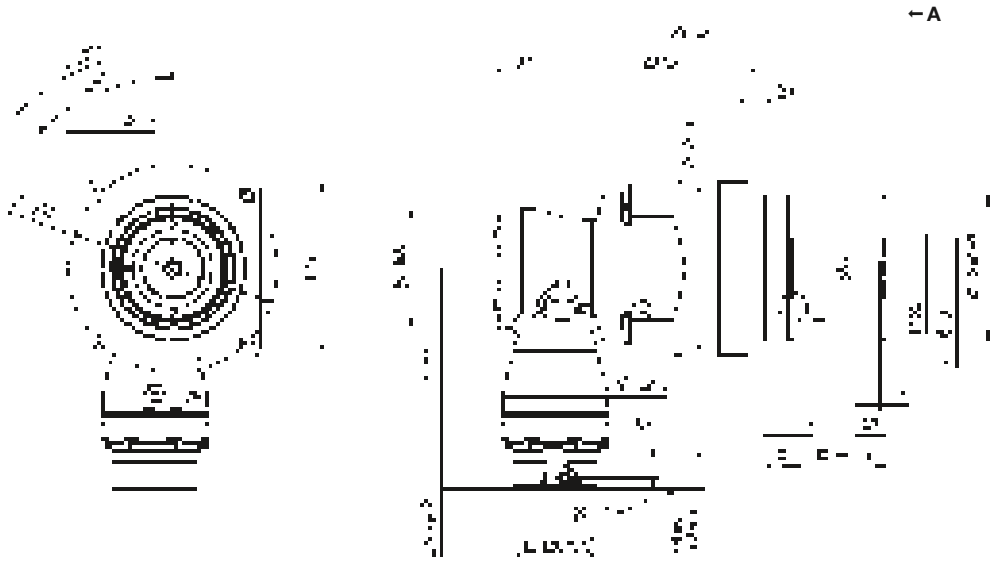

Hypoid gearboxes

SPK

Other output variants

Shaft with key

Splined shaft (DIN 5480)

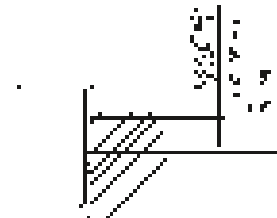
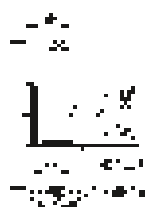

See technical data sheet for available clamping hub diameters (mass moment of inertia). Dimensions available on request.

Non-tolerated dimensions are nominal dimensions
¹⁾ Check motor shaft fit

²⁾ Min./Max. permissible motor shaft length. Longer motor shafts are possible, please contact alpha.

³⁾ The dimensions depend on the motor

⁴⁾ Smaller motor shaft diameter is compensated by a bushing with a minimum thickness of 1 mm

⁵⁾ Standard clamping hub diameter

SPK+ 240 MF 4-stage i=1225-10000

			4-stage									
Ratio	<i>i</i>		1225	1400	1750	2000	2800	3500	5000	7000	10000	
Max. torque ^{a) b) e)}	T_{2a}	Nm	5700	5700	5700	4200	5446	5700	5700	5700	3642	
		in.lb	50450	50450	50450	37173	48201	50450	50450	50450	32235	
Max. acceleration torque ^{b) e)} (max. 1000 cycles per hour)	T_{2B}	Nm	5400	5400	5400	4200	5400	5400	5160	4730	3642	
		in.lb	47794	47794	47794	37173	47794	47794	45670	41864	32235	
Nominal torque (at n_n)	T_{2N}	Nm	2500	2500	2500	2500	2500	2500	2500	2300	1700	
		in.lb	22127	22127	22127	22127	22127	22127	22127	20357	15046	
Emergency stop torque ^{a) b) e)} (permitted 1000 times during the service life of the gearbox)	T_{2Not}	Nm	8500	8500	8500	8000	8500	8500	8500	8500	6850	
		in.lb	75232	75232	75232	70806	75232	75232	75232	75232	60628	
Permitted average input speed (at T_{2a} and 20 °C ambient temperature) ^{d)}	n_{1N}	n_{1T}	2900	2900	3200	3900	3900	3900	3900	3900	3900	
Max. input speed	n_{1Max}	rpm	4500	4500	4500	4500	4500	4500	4500	4500	4500	
Mean no load running torque ^{b)} (at $n_1 = 3000$ rpm and 20 °C gearbox temperature)	T_{012}	Nm	0.6	0.6	0.4	0.4	0.4	0.4	0.4	0.3	0.3	
		in.lb	5	5	4	4	4	4	4	3	3	
Max. backlash	j_t	arcmin	Standard ≤ 5.5 / Reduced ≤ 3.5									
Torsional rigidity ^{b)}	C_{t21}	Nm/arcmin	510	510	510	510	510	510	510	510	510	
		in.lb/arcmin	4514	4514	4514	4514	4514	4514	4514	4514	4514	
Max. axial force ^{c)}	F_{2AMax}	N	33000									
		lb _f	7425									
Max. lateral force ^{c)}	F_{2QMax}	N	30000									
		lb _f	6750									
Max. tilting moment	M_{2KMax}	Nm	5000									
		in.lb	44254									
Efficiency at full load	η	%	90									
Service life	L_h	h	> 20000									
Weight (incl. standard adapter plate)	m	kg	96									
		lb _m	212									
Operating noise (at reference ratio and reference speed – ratio-specific values available in cymex [®])	L_{PA}	dB(A)	≤ 71									
		°C	+90									
Max. permitted housing temperature		F	194									
		°C	0 to +40									
Ambient temperature		F	32 to 104									
Lubrication			Lubricated for life									
Direction of rotation			In- and output opposite direction									
Protection class			IP 65									
Metal bellows coupling (recommended product type – validate sizing with cymex [®])			BC2 - 06000AA - 085.000 - X									
Bore diameter of coupling on the application side		mm	X = 060.000 - 140.000									
Mass moment of inertia (relates to the drive)	G	24	J_1	kgcm ²	2.73	2.49	2.46	2.42	2.42	2.42	2.42	2.42
				10 ⁻³ in.lb.s ²	2.42	2.2	2.18	2.14	2.14	2.14	2.14	2.14
Clamping hub diameter [mm]	K	38	J_1	kgcm ²	9.64	9.4	9.37	9.33	9.33	9.33	9.33	9.33
				10 ⁻³ in.lb.s ²	8.53	8.32	8.29	8.26	8.26	8.26	8.26	8.26

Please use our sizing software cymex[®] for a detailed sizing – www.wittenstein-cymex.com
Please contact us for optimum sizing at S1 conditions (Continuous operation).

- ^{a)} At max. 10 % F_{2QMax}
- ^{b)} Valid for standard clamping hub diameter
- ^{c)} Refers to center of the output shaft or flange
- ^{d)} Please reduce input speed at higher ambient temperatures
- ^{e)} Smooth shaft

View A

Motor shaft diameter [mm]

4-stage

up to 24/38⁴⁾
(G⁵⁾/K) clamping
hub diameter

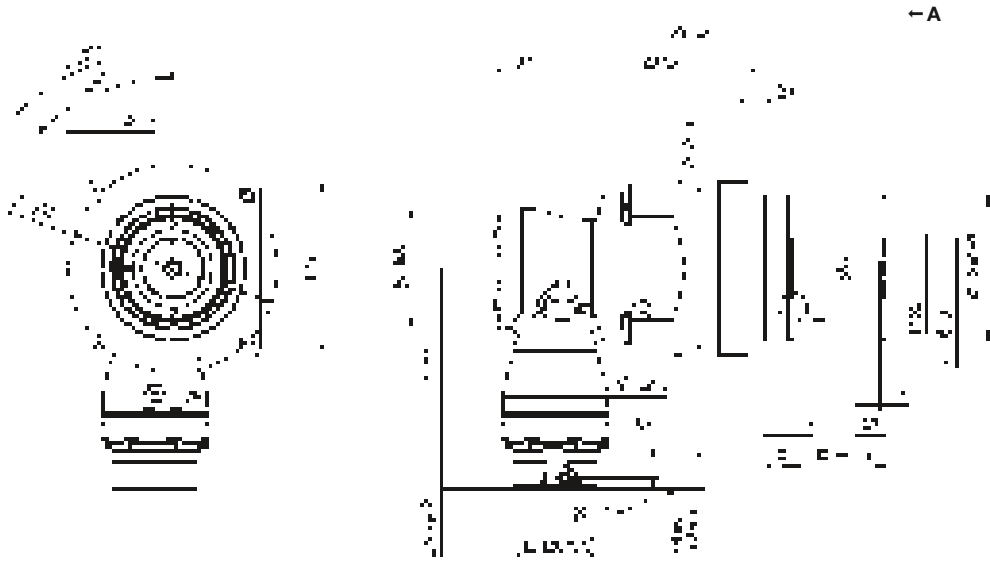

Hypoid gearboxes

SPK

Other output variants

Shaft with key

Splined shaft (DIN 5480)

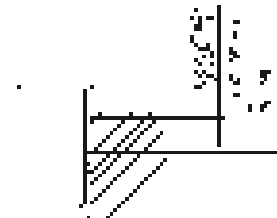
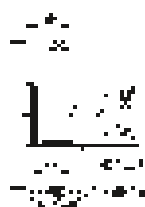

See technical data sheet for available clamping hub diameters (mass moment of inertia). Dimensions available on request.

Non-tolerated dimensions are nominal dimensions
¹⁾ Check motor shaft fit

²⁾ Min./Max. permissible motor shaft length. Longer motor shafts are possible, please contact alpha.

³⁾ The dimensions depend on the motor

⁴⁾ Smaller motor shaft diameter is compensated by a bushing with a minimum thickness of 1 mm

⁵⁾ Standard clamping hub diameter