

TORQUE ROTARY INDEXING TABLE

TO0150C / TO0220C-1 / TO0220C-2 (AIR/
WATER COOLING)

MOUNTING INSTRUCTIONS

TD0034A-EN00-0000-00

022019_2.0_EN

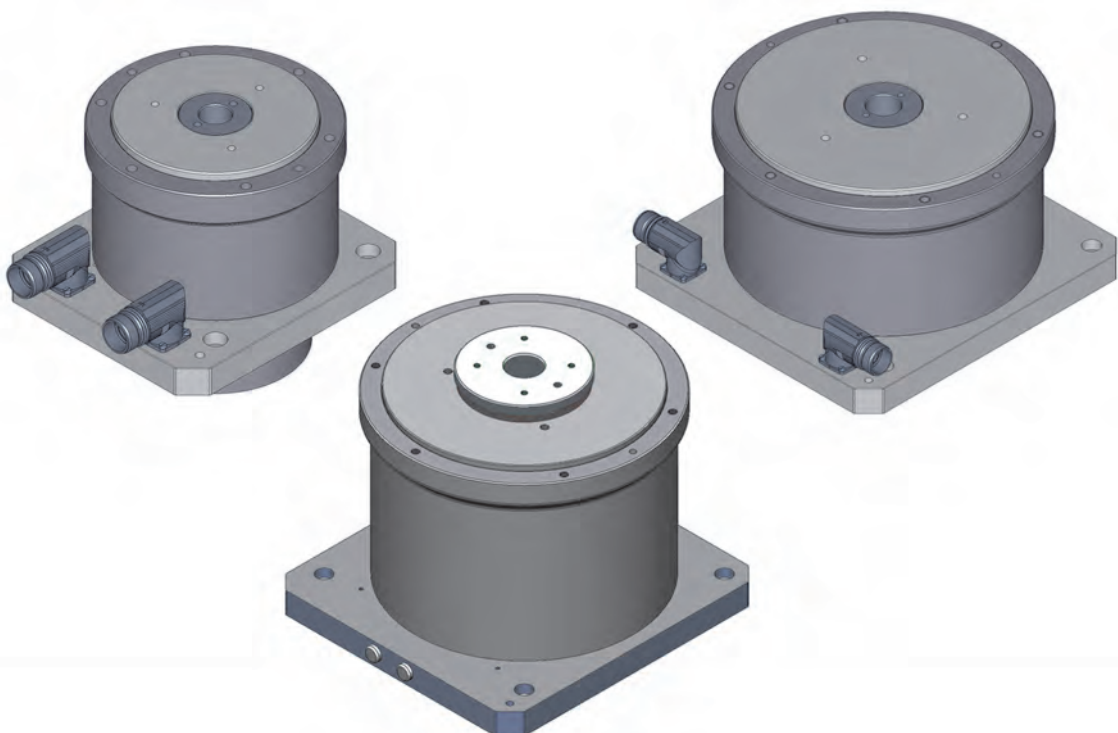

Table of contents

1	Introduction.....	5
1.1	About these mounting instructions.....	5
1.2	Intended use.....	5
1.3	Predictable incorrect application.....	6
1.4	Applicable documents.....	6
1.5	Warranty.....	7
2	Safety.....	8
2.1	Safety messages and hazard categories.....	8
2.2	Hazard symbols.....	9
2.3	Responsibilities of the system integrator and/or operator.....	9
2.4	Qualification of personnel.....	10
3	Product description.....	11
3.1	Overview.....	11
3.2	Function description.....	13
3.3	Nameplate.....	13
3.4	Type code.....	14
3.5	Mounting positions.....	15
3.6	Passage of media.....	16
4	Technical data.....	17
4.1	General.....	17
4.2	Motor.....	17
4.3	Encoder.....	18
4.4	Water cooling (optional).....	18
4.5	Climatic environmental conditions "Operation".....	19
4.6	Climatic environmental conditions "Transportation and Storage".....	19
4.7	Dimensions.....	20
4.8	Load data.....	23
5	Packaging.....	24
5.1	Types of packaging.....	24
5.2	Unpacking the product.....	24
5.3	Verification of the delivery.....	25
6	Transportation.....	26
6.1	Transporting the product.....	26
6.2	Load lifting and handling equipment.....	27
6.3	Fastening the load lifting and handling equipment.....	28

7	Storage	29
7.1	Storing the product.....	29
8	Mounting	30
8.1	Prerequisites for mounting.....	30
8.2	Equipment and tools.....	30
8.3	Tightening torques and property classes.....	30
8.4	Bolting down the product.....	31
8.5	Connecting the cooling water line (optional).....	33
8.6	Mounting additional components.....	35
8.7	Mounting safety equipment.....	37
9	Electrical connection	38
9.1	Connection assignment.....	39
10	Controller	41
10.1	Basic information on control.....	41
10.2	WEISS GmbH controller/software package (optional).....	41
11	Commissioning	42
11.1	Prerequisites for commissioning.....	42
11.2	Performing commissioning.....	42
12	Operation	45
12.1	Basic information on operation.....	45
13	Troubleshooting	47
13.1	Issue, cause and remedy.....	47
14	Cleaning	48
14.1	Performing cleaning.....	48
15	Maintenance	50
15.1	Maintenance plan.....	50
15.2	Lubricant.....	50
16	Decommissioning	50
16.1	Decommissioning the product.....	50
17	Dismounting	51
17.1	Dismounting the product.....	51
18	Disposal	51
18.1	Disposing of the product.....	51
19	Service and spare parts	52
19.1	Worldwide service.....	52



19.2 Ordering spare parts..... 53

1 Introduction

1.1 About these mounting instructions

These mounting instructions describe the product "Torque Rotary Indexing Table TO0150C / TO0220C-1 / TO0220C-2 (air/water cooling)" (also referred to as "product" in this document).

These mounting instructions are part of the product.

- You may only use the product if you have fully read and understood these mounting instructions.
- Verify that these mounting instructions are always accessible for any type of work performed on or with the product.
- Pass these mounting instructions as well as all other product-related documents on to all owners of the product.
- If you feel that these mounting instructions contain errors, inconsistencies, ambiguities or other issues, contact the manufacturer prior to using the product.

These mounting instructions are protected by copyright and may only be used as provided for by the corresponding copyright legislation. We reserve the right to modifications.

The manufacturer shall not be liable in any form whatsoever for direct or consequential damage resulting from failure to observe these mounting instructions or from failure to comply with directives, regulations and standards and any other statutory requirements applicable at the installation site of the product.

1.2 Intended use

The product is a partly complete machine pursuant to Directive 2006/42/EU, articles 1g and 2g. The product is only intended to be incorporated into or assembled with other machinery or other partly completed machinery or equipment, thereby forming machinery to which Directive 2006/42/EU applies.

The product may only be used within the limits specified in these mounting instructions and in the applicable documents. The applicable documents are also part of the product.

The machinery must not be put into service until the machinery into which the product has been incorporated has been determined and declared in conformity with the provisions of Directive 2006/42/EU and with all other applicable directives and regulations.

In addition, perform a risk assessment in view of the planned application, according to an approved risk assessment method, and implement the appropriate safety measures, based on the results of the risk assessment. Take into account the consequences of installing or integrating the product into a system or a plant.

When using the product, perform all work and all other activities in conjunction with the product in compliance with the conditions specified in the mounting instructions, in the applicable documents, and on the nameplate, as well as with all directives, standards, and safety regulations applicable at the installation site of the product.

1.3 Predictable incorrect application

Any use of the product beyond the explicitly indicated intended use is an impermissible, incorrect application of the product.

The product must never be used in the following cases, under the following conditions, and for the following purposes:

- Operation in residential environments
- Operation in life-supporting systems
- Operation in potentially explosive atmospheres/hazardous areas
- Operation on ships, in rail vehicles, land craft or in aircraft
- Operation in military facilities
- Operation outside of the specified order data
- Applications involving transportation of persons (fairground rides)

1.4 Applicable documents

In addition to these mounting instructions, the following documents are binding for and apply to any type of use of the product:

- Order data (including, but not limited to, design data, load data, performance data, transportation and storage instructions, information attached to the product and the package, as well as other specifications).
- Documentations of the manufacturers of all products belonging to the scope of delivery (for example, motor, accessories, attachment parts). This includes, among other things:

Type of manual	Type	Manufacturer	Delivery	
			Paper format	Electronic
Manual	Encoder ECN 113	DR. JOHANNES HEIDENHAIN GmbH	-	X
Manual	Angle encoder ECN 225	DR. JOHANNES HEIDENHAIN GmbH	-	X
Safety data sheet	Lubricant LE-Spezialfett Synt EP 2	HERM GmbH & Co. KG	-	X
Technical datasheet	Additives Glysantin G48	BASF SE	-	X
Technical datasheet	Additives Avia Antifreeze APN	AVIA MINERALÖL AG	-	X
Technical datasheet	Additives ZEREX G48 Antifreeze Coolant G48	Valvoline LLC	-	X
In the case of delivery with WEISS GmbH controller/software package:			Delivery	
			Paper format	Electronic
User manual	"W.A.S. 2 COMPACT" TD0079A-XX00-0000-00	WEISS GmbH	-	X



In the case of delivery with WEISS GmbH controller/software package:			Delivery	
			Paper format	Electronic
User manual	"W.A.S. 2 SCALABLE" TD0081A-XX00-0000-00	WEISS GmbH	-	X
Electrical documenta- tion	List of applicable documents, per product (see documents on the CD delivered with the product)	WEISS GmbH	-	X

1.5 Warranty

See our website for our General Terms and Conditions at www.weiss-international.com or your purchase order.

2 Safety

2.1 Safety messages and hazard categories

These mounting instructions contain safety messages to alert you to potential hazards and risks. Safety messages in these mounting instructions are highlighted with warning symbols and warning words.

The signal word describes the source of the hazard. The text contains instructions on how to avoid the hazard as well as the consequence resulting from failure to follow the instructions given in the safety message.

Depending on the severity of a hazard, the safety messages are classified according to different hazard categories.



⚠ DANGER

DANGER indicates an immediately hazardous situation, which, if not avoided, will result in death or serious injury.



⚠ WARNING

WARNING indicates a hazardous situation, which, if not avoided, can result in death or serious injury or equipment damage.



⚠ CAUTION

CAUTION indicates a hazardous situation, which, if not avoided, can result in injury or equipment damage.

NOTICE

NOTICE indicates a hazardous situation, which, if not avoided, can result in equipment damage.

In addition to the instructions and safety messages provided in these mounting instructions, you must comply with all directives, standards, and safety regulations applicable at the installation site of the product.

2.2 Hazard symbols

The following symbols are used in these mounting instructions:



This is the general safety alert symbol. It alerts to injury hazards or equipment damage. Comply with all safety instructions in conjunction with this symbol to help avoid possible death, injury, or equipment damage.



This symbol alerts to hazardous electrical voltage. If this symbol is used in a safety message, there is a hazard of electric shock.

Hazard symbols may also be attached to the product.



Hazard of hot surface



Hazard of magnetic field



No access for persons with heart pacemakers or other medical implants

2.3 Responsibilities of the system integrator and/or operator

The system integrator (the person who incorporates the product in a machine pursuant to Directive 2006/42/EU, i.e., for example, the machine builder) and/or the operator must ensure the following:

- The application and use of the product must be limited to the specified intended use.
- In the integration of the product, all functional safety requirements must be met.
- All directives, standards, and safety regulations, including all regulations concerning workplace safety and prevention of accidents, applicable at the installation site of the product must be complied with.
- Any type of work whatsoever on and with the product may only be performed by qualified personnel.
- The product may only be operated when it is in flawless, fully functional condition.
- All safety equipment must operate as required and planned.
- The personal protective equipment for the personnel/operator must be available and must be used.
- The mounting instructions and all applicable documents must always be accessible in their entirety to the personnel at the installation site of the product.
- Safety instructions, labels, and any other information attached to the product must not be removed.
- A complete manual must be available for the machine into which the product is incorporated; this manual must describe all types of work on and with the machine and contain all information relevant with regard to the product.

If the system integrator himself is not in the position to comply with any of these obligations, the system integrator must impose compliance with these obligations on the operator.

2.4 Qualification of personnel

Only trained personnel who have fully read and understood the mounting instructions and all applicable documents for the product may perform work on and with the product.

This trained personnel must have sufficient technical training, knowledge, and experience, and be able to foresee and detect potential hazards that may be caused by using the product.

All trained personnel working on and with the product must be fully familiar with all directives, standards, and safety regulations that must be observed for performing such work.

3 Product description

3.1 Overview

The product consists of the following components:

Product type: TO0150C

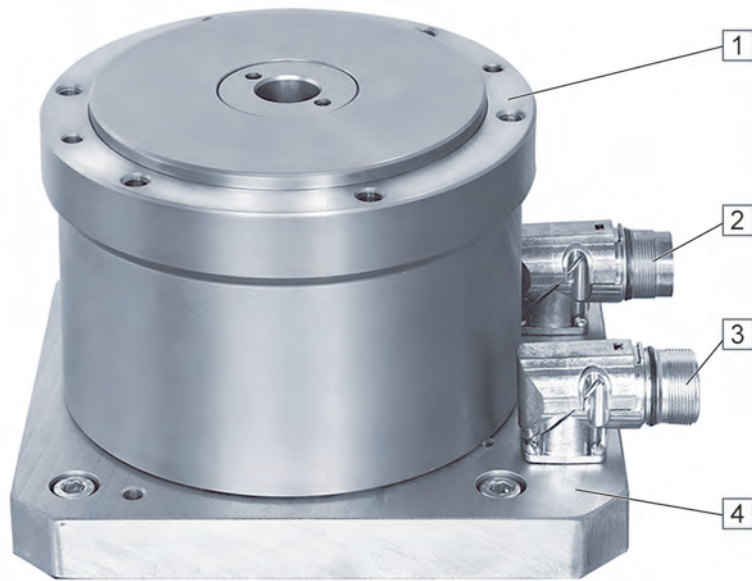

1 Output flange with mounting surface

2 Connection encoder cable

3 Connection motor cable

4 Housing

Product type: TO0220C-1



- | | | | |
|---|---|---|--------------------------|
| 1 | No mounting surface (auxiliary holes resulting from production) | 4 | Connection encoder cable |
| 2 | Output flange with mounting surface | 5 | Connection motor cable |
| 3 | Housing | | |

Product type: TO0220C-2 (air/water cooling)

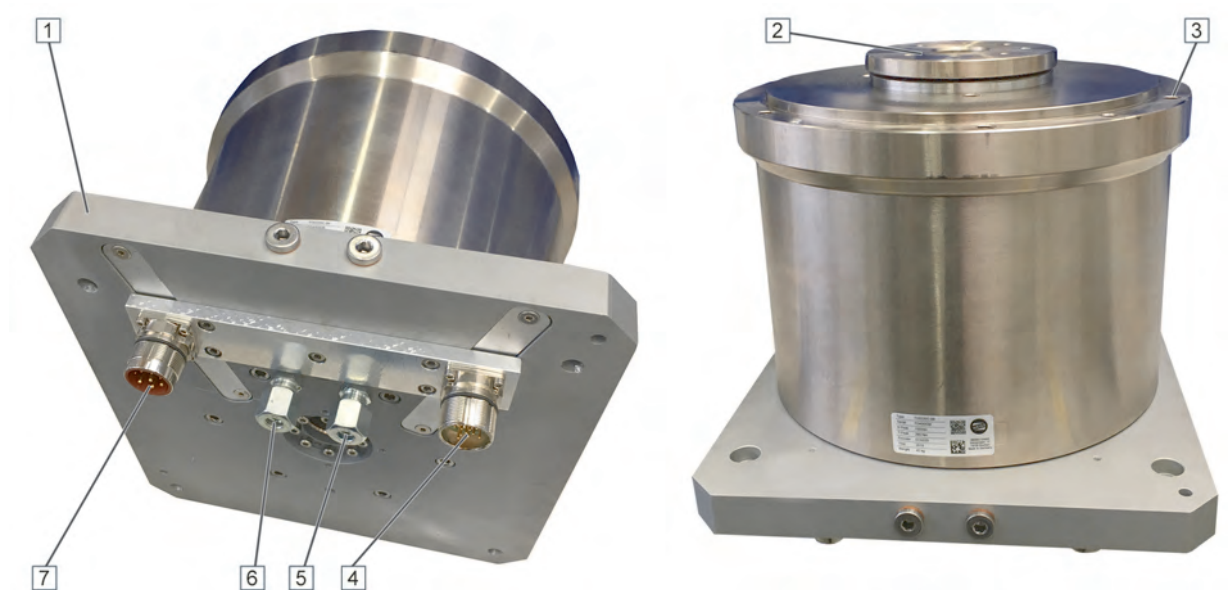

- | | | | |
|---|-------------------------------------|---|---------------------------------|
| 1 | Housing | 5 | Connection cooling water inlet |
| 2 | Stationary center part | 6 | Connection cooling water outlet |
| 3 | Output flange with mounting surface | 7 | Connection motor cable |
| 4 | Connection encoder cable | | |

3.2 Function description

The motor is controlled by a servo drive and rotates, accelerates or decelerates the output flange of the product.

The output flange can be operated with the following directions of movement: left, right, or alternating.

The integrated encoder provides for high positioning accuracy and repeatability.

3.3 Nameplate

The nameplate is attached to the housing of the product; it contains the following information:



- | | | | |
|---|---------------------------|---|---------------------------|
| 1 | Type | 6 | Year of manufacture |
| 2 | Serial number | 7 | Weight |
| 3 | Maximum speed of rotation | 8 | QR code (company website) |
| 4 | Peak torque | 9 | DM code (serial number) |
| 5 | Encoder | | |

The scope of delivery contains a second nameplate. If the factory-mounted nameplate is covered by attachments, the second nameplate can be attached at a readily visible position of the product or machine for identification of the product.

3.4 Type code

Structure of the type code:

Type	Diameter of output flange (mm)	Motor version	Encoder	Winding
TO	0150C 0220C	1 = single-row magnetic ring 2 = double-row magnetic ring	A = ECN113 A = ECN225	B = 150/min C = 150/min

3.5 Mounting positions

NOTICE

EQUIPMENT DAMAGE DUE TO INCORRECT MOUNTING POSITION

Failure to follow these instructions can result in equipment damage.

- Verify that you only use the standard mounting positions approved in these mounting instructions.
- Only use special mounting positions if such special mounting positions have been approved by the manufacturer in writing.

Permissible standard mounting positions

The product may only be mounted as shown below.



Horizontal

Special mounting positions

The following special mounting positions require explicit approval of the manufacturer for the product.



Upside down



Vertical

3.6 Passage of media

Product types: TO0150C/TO0220C-1/TO0220C-2 (air/water cooling)

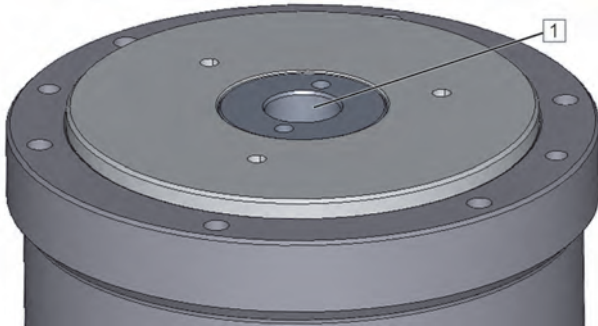

The large center hole [1] can be used for the passage of media.

4 Technical data

4.1 General

Characteristic	Unit	Value			
		TO0150C	TO0220C-1_B	TO0220C-2_B (air cooling)	TO0220C-2_C (water cooling)
Direction of rotation	-	Any			
Repeatability	arcsec	± 8"	± 7"	± 7"	± 7"
Maximum axial runout of plate at table plate diameter	mm	± 0.01			
Maximum radial runout at table diameter	mm	± 0.01			
Weight	kg	16	32	42	
Weight with packaging	kg	See bill of delivery			
Sound pressure	dB(A)	< 70			
Lubricant	-	LE-Spezialfett Synt EP 2			

4.2 Motor

Characteristic	Unit	Value			
		TO0150C	TO0220C-1_B	TO0220C-2_B (air cooling)	TO0220C-2_C (water cooling)
Number of pole pairs	-	14	21	21	21
Voltage range	V	560	560	400	400
Voltage constant	mV/min	585	1158	2138	2138
Maximum speed of rotation	min ⁻¹	240	250	80	110
Stall torque	Nm	16	54	97.6	194
Nominal torque	Nm	16	54	98	194
Peak torque	Nm	45	130	260	260
Torque constant	Nm/A _{rms}	9.6	18.3	34.8	34.8
Stall current	A	2.48	3.5	4	4
Nominal current	A	2.48	3.5	4	4
Peak current	A	6.23	9	11	11
Winding cross section	mm ²	0.17721	0.70514	0.738	0.738
Stator resistance at 20°C*	Ohm	27.8	9.3	11.3	11.3

Characteristic	Unit	Value			
Stator inductance*	Henry	0.1025	0.082	0.113	0.113
Moment of inertia	kgm ²	0.04	0.16	0.26	0.26
Temperature monitoring	-	Triple PTC	Triple PTC	Triple PTC	Triple PTC

* Measured between phase and phase.

4.3 Encoder

Refer to the documentation of the manufacturer for the technical data of the encoder; see applicable documents.

Characteristic	Value	
	TO0150CAx / TO0220CAx	TO0150CAx / TO0220CAx
Manufacturer	DR. JOHANNES HEIDENHAIN GmbH	
Type	ECN113	ECN225
Function	Absolute	
Interface	EnDat 2.1	
Number of data bits	2048 sin/cos + 13 bits	2048 sin/cos + 25 bits

4.4 Water cooling (optional)

NOTICE

INSUFFICIENT COOLING

Deposits and corrosion in the cooling channels of the product and in the cooling system can reduce the cooling capacity.

Failure to follow these instructions can result in equipment damage.

- Add the additives specified in these mounting instruction or equivalent additives to the cooling water.
- Verify that you take into account all instructions and specifications of the manufacturers of the additives.

Characteristic	Unit	Value
		TO0220C-2_C (water cooling)
Coolant	-	Water with the specified additives (corrosion inhibitor, antifreeze, water may be demineralized)
Cooling circuit	-	Sealed (no contact of coolant with air)
Flow rate	l/min	4.8
Flow temperature	°C	20

Characteristic	Unit	Value
Inside diameter supply line	mm	12
Length supply line	m	4
Inside diameter return line	mm	12
Length return line	m	4
Pressure loss in the motor	bar	4
Connection as per DIN 2353 (diameter)	mm	8

Additives*

Manufacturer	Product designation	Recommended dilution in water
BASF SE	Glysantin G48	33 ... 50 %
AVIA MINERALÖL AG	Antifreeze APN	*
Valvoline LLC	ZEREX G48 Antifreeze Coolant G48	*

* Mixing ratios according to the instructions of the manufacturers

4.5 Climatic environmental conditions "Operation"

Characteristic	Unit	Value
Ambient temperature	°C	+15 ... +45
Relative humidity, non-condensing	%	+5 ... +95
Maximum surface temperature	°C	80
Maximum installation altitude above mean sea level without derating motor and drive/frequency inverter	m	1000

4.6 Climatic environmental conditions "Transportation and Storage"

Characteristic	Unit	Value
Ambient temperature	°C	+5 ... +60
Relative humidity, non-condensing	%	+5 ... +95
Maximum storage duration of the mechanical components; see below for conditions	-	see chapter 7

4.7 Dimensions

Product type: TO0150C

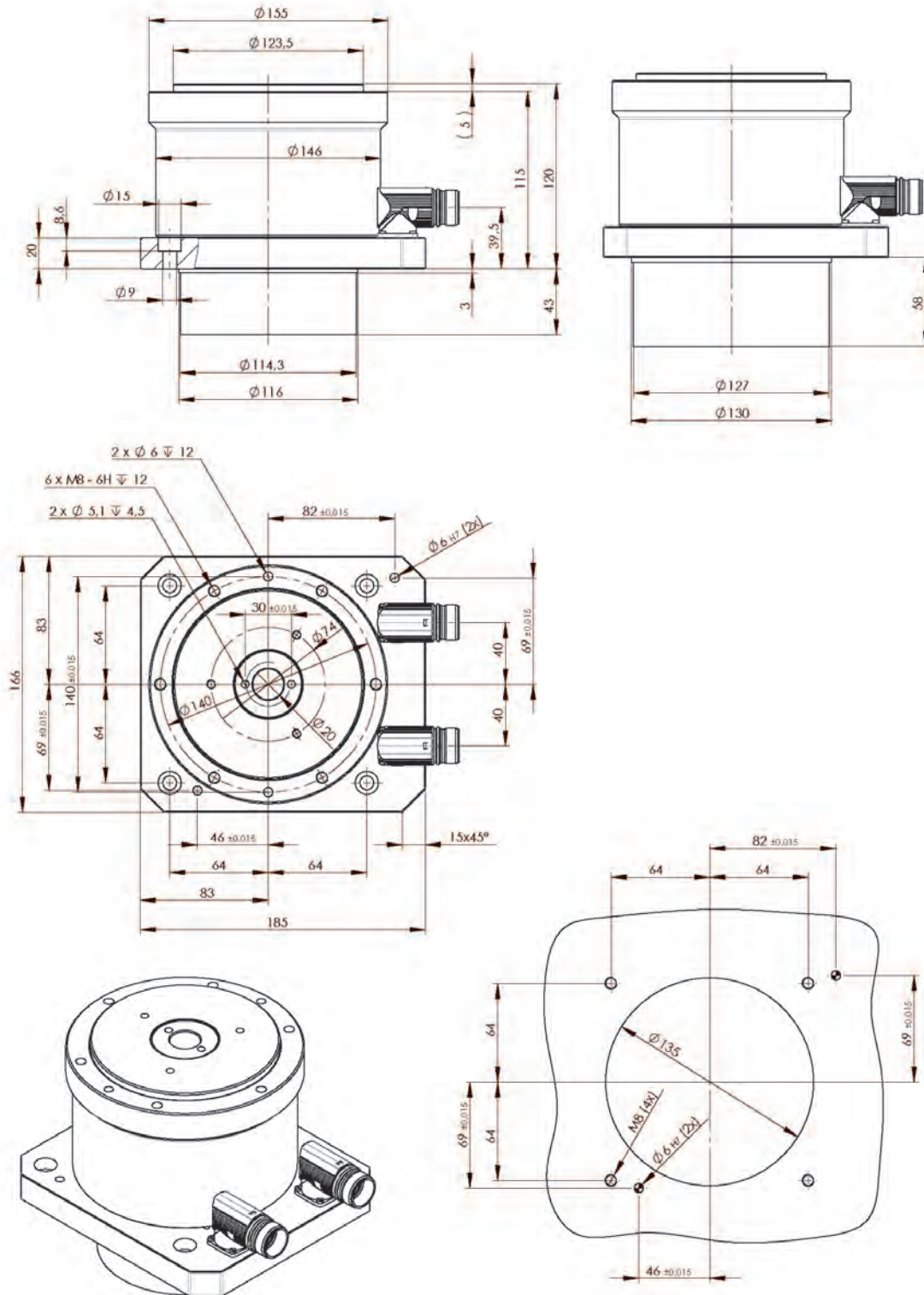

Product type: TO0220C-1

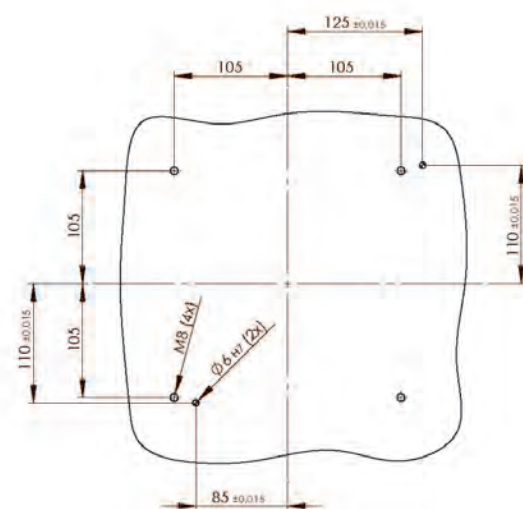
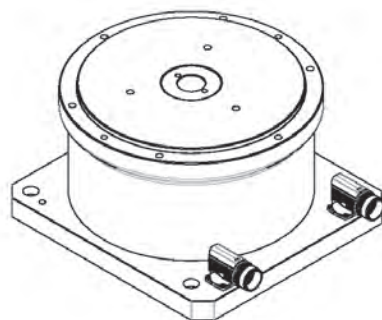
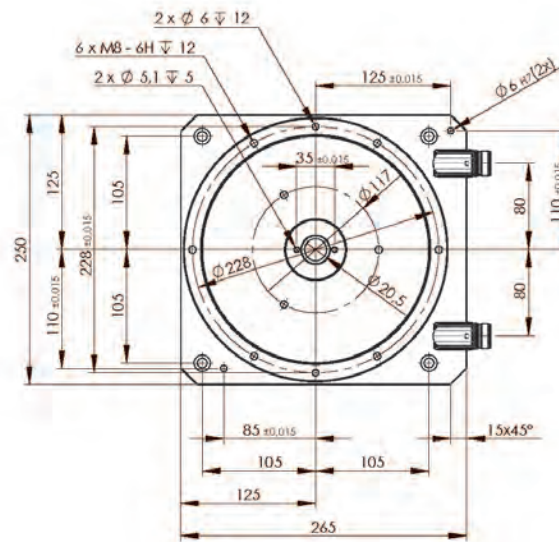
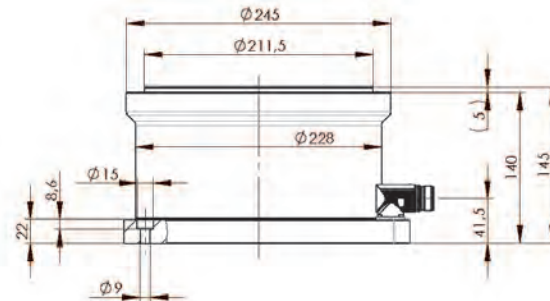

Product type: TO0220C-2 (air/water cooling)

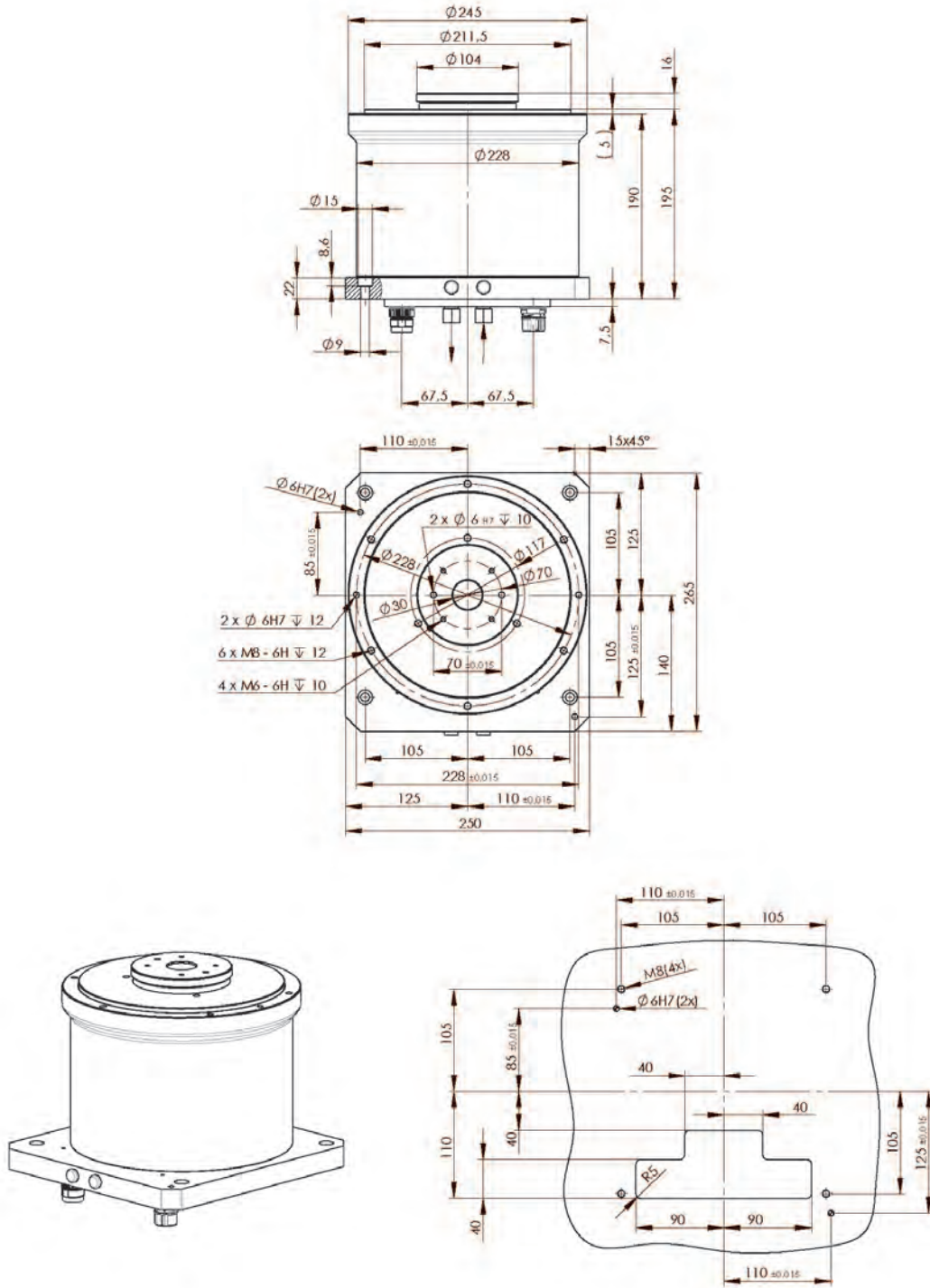

4.8 Load data

Load data for stationary center part

Characteristic	Unit	Value			
		TO0150C	TO0220C-1_B	TO0220C-2_B (air cooling)	TO0220C-2_C (water cooling)
Maximum permissible torque	Nm	-	-	200	200
Maximum permissible moment of tilt	Nm	-	-	500	500
Maximum permissible axial force	N	-	-	5000	5000
Maximum permissible radial force	N	-	-	5000	5000

Load data for output flange

Characteristic	Unit	Value			
		TO0150C	TO0220C-1_B	TO0220C-2_B (air cooling)	TO0220C-2_C (water cooling)
Maximum permissible static axial force	N	6000	10000	10000	10000
Maximum permissible static radial force	kN	10000	15000	15000	15000
Maximum permissible static moment of tilt	Nm	600	1000	1000	1000

5 Packaging

5.1 Types of packaging



Packaging in Europe

The product is factory-treated with anti-corrosion agent, packaged in film and screwed onto a palette.



Packaging for air and sea freight

The product is factory-treated with anti-corrosion agent, packaged in Corpac-coex-VCI film, screwed onto a palette, and then packed into a wooden box with foam plastic material.

5.2 Unpacking the product

1. Do not remove the packaging until immediately prior to mounting.
2. Dispose of the packaging material in compliance with all directives, standards, and safety regulations applicable at the installation site.

5.3 Verification of the delivery

- Check the delivery for completeness and transportation damage upon reception.
- In the case of damage, reject the delivery or accept it only conditionally.
- Document the damage in the transportation documents/bill of delivery (any damage detected must be immediately reported to the forwarding agent and confirmed by the forwarding agent).
- Take photographs of the damage.
- Report the damage to WEISS GmbH.

6 Transportation



▲ WARNING

FALLING, TOPPLING, OR LOWERING LOADS

Insufficiently rated load lifting and handling equipment may break. Transportation vehicles, lifting gear, chains, belts, and other equipment not rated for the product may fail or tilt.

Failure to follow these instructions can result in death, serious injury, and equipment damage.

- Only use transportation vehicles, lifting gear, chains, belts, and other lifting and handling equipment that comply with all applicable regulations and that are rated for the weight of the product including packaging.
- Verify that there are no persons in the danger zone.
- Verify that the product is properly secured against falling and toppling.

6.1 Transporting the product

Packages fastened to a pallet can be transported with a fork lift truck, a pallet jack or similar transportation means. Verify that the transportation means used is suitable and approved for the weight and the dimensions of the package.



1. Place the forks below the pallet.
2. Verify that the pallet with the package fully rests on the forks.
3. Fasten the pallet with the package using additional straps if the center of gravity is not in the center of the pallet.

6.2 Load lifting and handling equipment



Use properly rated load lifting and handling equipment and hoisting belts/hoisting equipment for transporting the product. Eyebolts must not be used as load lifting and handling equipment.

6.3 Fastening the load lifting and handling equipment



⚠ WARNING

FALLING, TOPPLING, OR LOWERING LOADS

Insufficiently rated load lifting and handling equipment may break. Transportation vehicles, lifting gear, chains, belts, and other equipment not rated for the product may fail or tilt.

Failure to follow these instructions can result in death, serious injury, and equipment damage.

- Only use transportation vehicles, lifting gear, chains, belts, and other lifting and handling equipment that comply with all applicable regulations and that are rated for the weight of the product including packaging.
- Verify that there are no persons in the danger zone.
- Verify that the product is properly secured against falling and toppling.

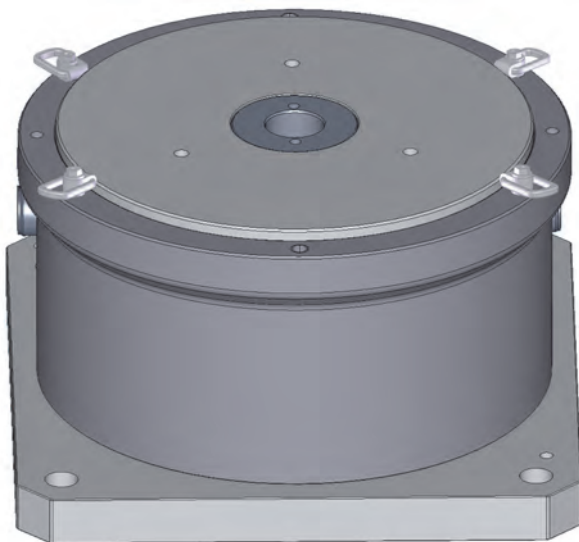

1. Use properly rated load lifting and handling equipment and hoisting belts/hoisting equipment for transporting the product.
2. Screw the load lifting and handling equipment (M8) into the outer threads of the output flange.
3. Fasten the hoisting belts or the hoisting equipment to the eyelets of the load lifting or load handling equipment.

Product type	Number of pieces of load lifting and handling equipment	Thread
TO0150C	-	-
TO0220C-1 TO0220C-2 (air/water cooling)	4	M8

7 Storage

7.1 Storing the product

NOTICE

INCORRECT STORAGE

Failure to follow these instructions can result in equipment damage.

- Verify compliance with all conditions specified in these mounting instructions and all applicable documents when storing the product.

The mechanical components of the product can be stored for a period of up to two years.

Conditions for specified maximum storage duration:

- Storage in original packaging
- Compliance with all specified storage conditions
- Storage in suitable closed, dry, dust-free room, protected against direct sunlight
- No contact with corrosive media
- Corrosion protection intact

The electrical components have a different maximum storage duration (see documentations of the manufacturers).

If the maximum storage duration has been exceeded, you must contact the manufacturer prior to commissioning the product. This also applies if the machine in which the product has been incorporated has not been operated for a period of time exceeding the maximum storage durations specified for the mechanical and electrical components.

If you plan to store the product for a period of time exceeding the maximum permissible storage duration specified for the mechanical components, you must uninstall the electrical components prior to storing the product. The electrical components must be stored according to the specifications of the manufacturers (see documentations of the manufacturers).

If the product is to be stored for a period of more than three months, the product must first be preserved. If the factory-applied anti-corrosion agent is no longer intact, you must request preservation instructions from the manufacturer.

8 Mounting

8.1 Prerequisites for mounting

Prior to mounting, the anti-corrosion and any pollution must be removed with a standard solvent.

Prior to mounting, verify that the dimensions of the installation site and construction conditions meet the requirements and the dimensions specified in these mounting instructions and the applicable documents.

- Verify that the supporting base is level and rigid.
- Verify that the supporting structure at the installation site has a sufficient structural strength to carry the weight of the product and of all loads.

8.2 Equipment and tools

The following is required for mounting:

- Set of hex keys
- Torque wrench
- Ball pane hammer
- Cotter pin punch (for mounting the parallel pins)
- Standard solvent

8.3 Tightening torques and property classes

Only use screws with the property class shown in the following table unless a different property class is explicitly specified for a screw connection.

Use the tightening torque shown in the following table unless a different tightening torque is explicitly specified for a screw connection.

Property class of screws	10.9 (coefficient of friction μ_{tot} 0.12)				
Thread	M8	M10	M12	M16	M20
Tightening torque	34 Nm	68 Nm	117 Nm	285 Nm	557 Nm

8.4 Bolting down the product



WARNING

FALLING, TOPPLING, OR LOWERING LOADS

Insufficiently rated load lifting and handling equipment may break. Transportation vehicles, lifting gear, chains, belts, and other equipment not rated for the product may fail or tilt.

Failure to follow these instructions can result in death, serious injury, and equipment damage.

- Only use transportation vehicles, lifting gear, chains, belts, and other lifting and handling equipment that comply with all applicable regulations and that are rated for the weight of the product including packaging.
- Verify that there are no persons in the danger zone.
- Verify that the product is properly secured against falling and toppling.



WARNING

IMPROPERLY FASTENED PARTS

Failure to follow these instructions can result in death, serious injury, and equipment damage.

- Verify that the supporting structure and/or the frame and/or the mounting surface for fastening the product are sufficiently rated to withstand all static and dynamic loads and forces during operation.
- Verify that the fastening parts comply with the specifications indicated and that they are sufficiently rated for all load conditions during operation.

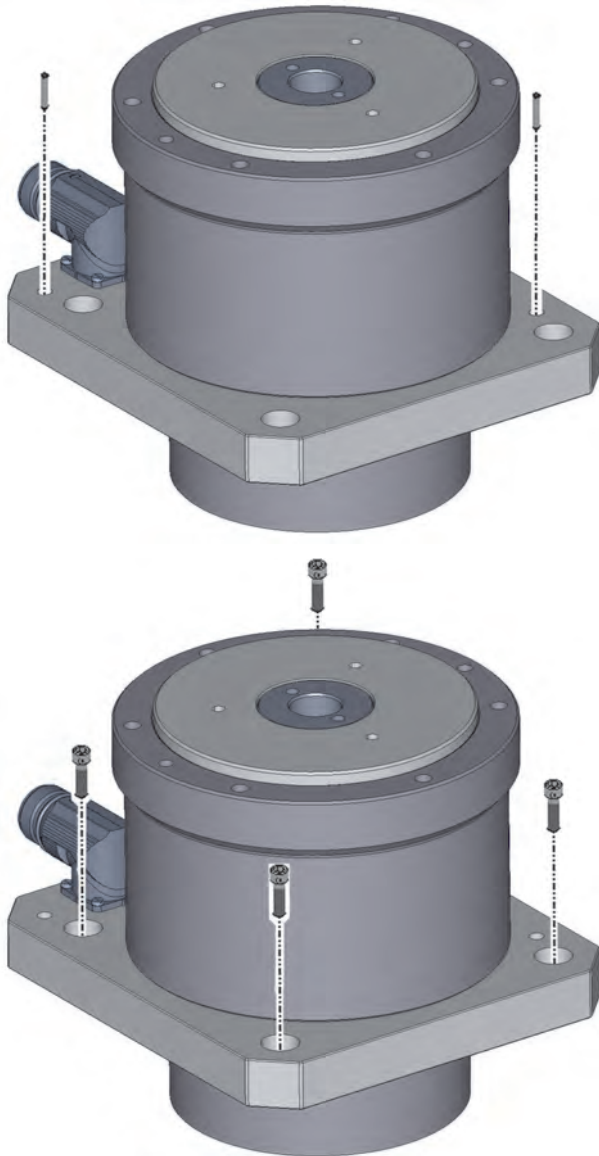

Use M8 screws with the property class specified to mount the product. When determining the length of the screws, take into account the loads and forces acting in your application as well as the characteristics of the supporting structure to which the product is mounted.

1. Place the product at the mounting site in compliance with the transportation instructions and align it according to the holes and the pin holes.
2. Center the product with the two parallel pins and then drive in the first parallel pin by one third.
3. Screw in all screws (M8) and tighten them.
4. Drive in all parallel pins (positive fit, the parallel pin must be in contact with the housing and the mounting plate/mounting surface).
5. Tighten all screws (M8) cross-wise with the specified tightening torque.

8.5 Connecting the cooling water line (optional)

NOTICE

INSUFFICIENT COOLING

Failure to follow these instructions can result in equipment damage.

- Do not operate the product without water cooling.
- Verify that the water cooling system is monitored in a sufficient way (for example, by means of temperature monitoring, flow monitoring, leak monitoring and/or pressure monitoring).
- Implement suitable measures (for example, connection of the water cooling system to the master controller) to ensure that the motor and/or the machine are immediately powered down if the specified temperatures are exceeded.
- Verify that not extraneous objects or substances can get into the cooling channels of the motor (for example, by means of a suitable filter).
- Verify that leaking cooling water cannot cause any other hazards.

NOTICE

INSUFFICIENT COOLING DUE TO MECHANICAL INFLUENCES

Mechanical loads and stress can result in damage to the cooling water connections of the product. Unsuitable bend radii of the cooling water lines can reduce the flow rate.

Failure to follow these instructions can result in equipment damage.

- When connecting the cooling water lines, verify that the cooling water connections of the product are not subjected to mechanical loads and stress.
- When connecting the cooling water lines, verify that all radii of the cooling water line comply with the specifications of the manufacturer and that the cross sections of the cooling water lines are not reduced by the type of installation.

NOTICE

INSUFFICIENT COOLING

Deposits and corrosion in the cooling channels of the product and in the cooling system can reduce the cooling capacity.

Failure to follow these instructions can result in equipment damage.

- Add the additives specified in these mounting instruction or equivalent additives to the cooling water.
- Verify that you take into account all instructions and specifications of the manufacturers of the additives.

The product with water cooling is provided for connection of a water cooling system to the cooling water inlet and to the cooling water outlet. The water cooling system is not included in the scope of delivery of the product.

The water cooling system must be rated and provided by the system integrator and/or the operator. A product with water cooling must not be operated without a water cooling system. Rate the water cooling system in such a way that the motor is sufficiently cooled in all operating states.

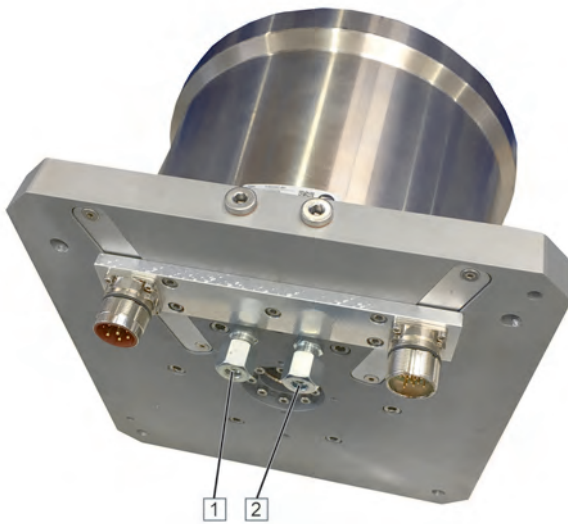

1. Unscrew the two screw plugs [1] and [2].
2. Connect the cooling water line for the cooling water inlet to connection [2].
3. Connect the cooling water line for the cooling water outlet to connection [1].

8.6 Mounting additional components



CAUTION

MECHANICAL DAMAGE

Failure to follow these instructions can result in injury or equipment damage.

- Only mount components to the output flange/stationary center part that are approved by the manufacturer.
- Only use existing holes in the output flange/stationary center part for mounting additional components to the output flange/stationary center part.
- After mounting, do not drill holes into the output flange/stationary center part.

Mounting an additional indexing plate

An additional indexing plate may only be mounted via the fit holes or with centering fits and threads.

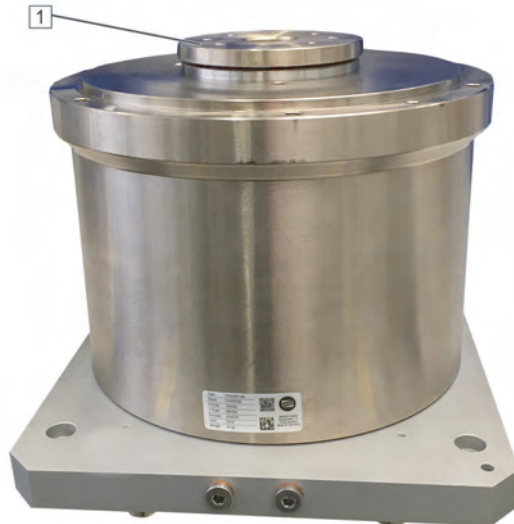

Stationary center part

1. Position the additional indexing plate.
2. Drive in the parallel pin by one third of the way.
3. Screw in all screws (M6) [1] and tighten them.
4. Fully drive in the parallel pin.
5. Tighten all screws (M6) [1] cross-wise with the specified tightening torque.

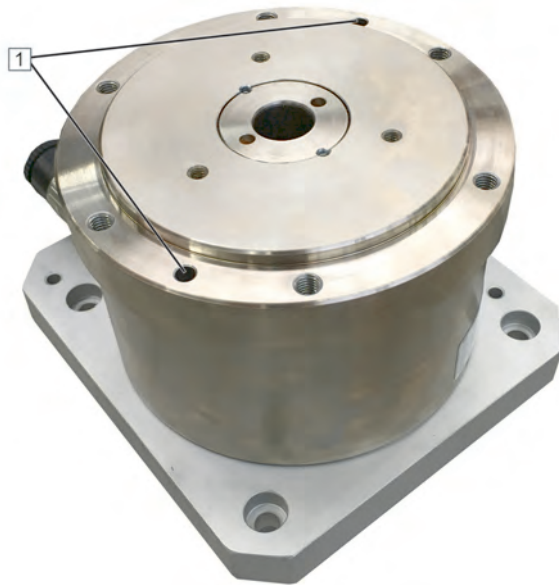
**Output flange**

1. Position the additional indexing plate.
2. Drive in the parallel pin [1] by one third of the way.
3. Screw in all screws (M10) [2] and tighten them.
4. Fully drive in the parallel pin [1].
5. Tighten all screws (M10) [2] cross-wise with the specified tightening torque.

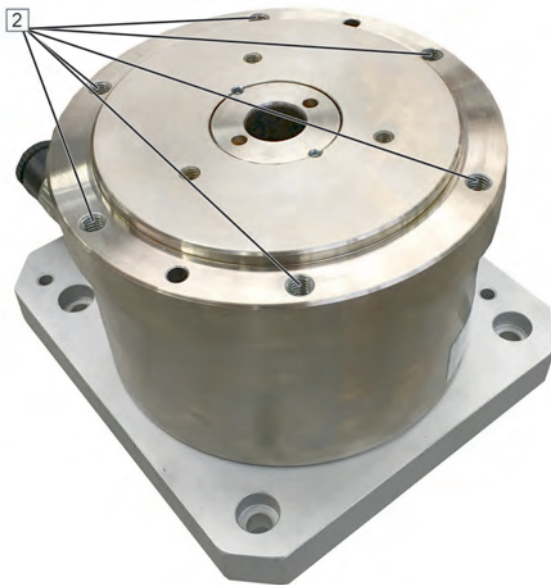

8.7 Mounting safety equipment

The product is a partly complete machine pursuant to Directive 2006/42/EU and intended to be incorporated into or assembled with other machinery. The requirements concerning functional safety and the corresponding safety equipment result from the risk analysis and the risk assessment for the final machine or plant.

Selection, mounting, installation, commissioning, operation and maintenance of the safety equipment must be performed by the system integrator (the person who incorporates the product in a machine pursuant to Directive 2006/42/EU, i.e., for example, the machine builder) and/or the operator.

The product requires at least the following safety equipment:

- Emergency Stop system as per IEC 60204-1 / ISO 13850
- Lockable main switch to interrupt the complete power supply to all electrical components of the product

9 Electrical connection



⚠ DANGER

ELECTRIC SHOCK CAUSED BY LIVE PARTS

Failure to follow these instructions will result in death or serious injury.

- Disconnect the mains supply voltage before performing the work and ensure that it cannot be switched on.
- Verify that no hazards can be caused by electrically conductive objects.
- Verify that all cables for the power supply are disconnected from power.



⚠ DANGER

ELECTRIC SHOCK DUE TO INSUFFICIENT GROUNDING

Failure to follow these instructions will result in death or serious injury.

- Verify compliance with all local and national electrical code requirements as well as all other applicable directives, regulations, and standards with regard to grounding of the entire machine.
- Ground all components of the machine before applying voltage.
- Do not use cable conduits as protective ground conductors; instead, use a protective ground conductor inside the cable conduits.
- Verify that the cross section of the protective ground conductor complies with the applicable standards.
- Do not use cable shields as protective ground conductors.



⚠ WARNING

UNANTICIPATED MOVEMENT

Interchanging the motor connections inverts the direction of rotation of the motor.

Failure to follow these instructions can result in death, serious injury, and equipment damage.

- Verify correct wiring and connection of all electrical connections.



⚠ CAUTION

IMPROPERLY INSTALLED CABLES

Failure to follow these instructions can result in injury or equipment damage.



- Verify that the cables are correctly routed.
- Verify compliance with the bend radius specifications for the electrical lines.
- Only use cables with the correct cross sections.
- Verify that the electrical cables are correctly connected to the terminals.

The following components must be connected for the motor:



- Lockable main switch
- Suitable Emergency Stop equipment (as per IEC 60204-1 / EN ISO 13850)

9.1 Connection assignment

Connection motor

Motor connector with male thread M23	Isolation piece 8-pin E	Pin assignment		
		Pin	Designation	Function
		1	U	Motor phase U
		4	V	Motor phase V
		3	W	Motor phase W
		2	PE	Protective ground conductor
		A	T+	Temperature sensor +
		B	T-	Temperature sensor -
		C	---	---
		D	---	---

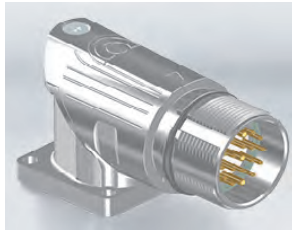
Encoder connection (EnDat 2.1)

Encoder connector with male thread M23	Isolation piece 17-pin E	Pin assignment		
		Pin	Designation	Function
		1	Sense 5 V	Sense + 5 V
		2	---	---
		3	---	---
		4	Sense GND	Sense GND
		5	---	---
		6	---	---
		7	5 V	Encoder 5 V
		8	CLOCK+	Clock
		9	CLOCK-	Clock inverted
		10	GND	GND
		11	---	---
		12	B+	Sine
		13	B-	Sine inverted
		14	DATA+	Data



Encoder connector with male thread M23	Isolation piece 17-pin E	Pin assignment		
		15	A+	Cosine
		16	A-	Cosine inverted
		17	DATA-	Data inverted

10 Controller

10.1 Basic information on control



▲ WARNING

LOSS OF CONTROL

Failure to follow these instructions can result in death, serious injury, and equipment damage.

- Consider all potential failure modes of all control paths in your control concept.
- Implement means and measures for all critical functions to achieve a safe state if a control path fails (for example, emergency stop, overtravel of positions, power outage, and restart).
- Implement separate or redundant control paths for all critical functions.
- If the control system of the machine comprises communication links, consider the consequences of unanticipated transmission delays or failures of the link and implement appropriate measures.
- Subject each machine in which the product described in these mounting instructions is used to a comprehensive and thorough commissioning test before operating the machine.

10.2 WEISS GmbH controller/software package (optional)

WEISS GmbH offers a controller/software package for controlling the product.

If this option is used, you must follow all instructions in the corresponding documentations. The documentations can be found on the CD shipped with the product in the controller/software package.

11 Commissioning

11.1 Prerequisites for commissioning

The following requirements must be met before the product may be commissioned:

- The product is properly mounted.
- The electrical equipment for the power supply of the electrical components of the product is correctly installed.
- All cables are properly routed and connected.
- All electrical connections have been made properly.
- All parts of the system are properly grounded in compliance with all applicable directives, regulations, and standards.
- All safety equipment and EMERGENCY-STOP circuits are operational.
- The drive is not damaged and not blocked.
- All environmental conditions are respected.
- All protective covers are properly mounted.
- All tools, equipment, and other objects have been removed from the zone of operation of the product.
- All hazards are excluded.
- The water cooling system has been checked for correct operation.

Prior to commissioning, perform a test for each prerequisite mentioned and verify compliance with all information and specifications contained in these mounting instructions, in all applicable documents, and in all applicable directives, regulations, and standards.

11.2 Performing commissioning



⚠ WARNING

UNANTICIPATED MOVEMENT

Incorrect connections or external influences on electrical equipment can cause unanticipated movements.

Failure to follow these instructions can result in death, serious injury, and equipment damage.

- Verify correct wiring.
- Verify that there are no persons or obstacles in the danger zone of the product before starting the product.
- Perform initial test movements without loads and without other processing units.
- Verify that all safety equipment and EMERGENCY STOP circuits are activated prior to commissioning.

**⚠ WARNING****UNINTENDED EQUIPMENT OPERATION**

Incorrect or unsuitable parameter values or settings can cause unintended movements, trigger signals, and compromise functional safety.

Failure to follow these instructions can result in death, serious injury, and equipment damage.

- Verify that parameter values and settings can only be modified by authorized personnel who fully understand each and every effect of such a modification.
- Verify that all parameter values and settings are correct by performing a test run.

**⚠ WARNING****ELECTROMAGNETIC FIELDS**

Failure to follow these instructions can result in death, serious injury, and equipment damage.



- Verify compliance with all international, national, and local directives, standards, and safety regulations, including all regulations concerning workplace safety and prevention of accidents, with regard to strong magnetic fields.
- Take all necessary measures to ensure that persons with active medical implants (such as heart pacemakers or insulin pumps), metal implants, and magnetically or electrically conductive objects are not exposed to do the magnetic fields generated by the product.
- Do not operate devices in the vicinity of the product which are sensitive to electromagnetic emission.
- Verify that a distance to the product of at least 15 cm is kept.

**⚠ WARNING****HOT SURFACES**

The temperature of the product can exceed 80 °C during operation.

Failure to follow these instructions can result in death, serious injury, and equipment damage.

- Avoid unprotected contact with hot surfaces.
- Do not allow flammable or heat-sensitive objects in the vicinity of hot surfaces.
- Before performing work on the product, verify that you wait for a sufficient period of time to allow such parts to cool down to a temperature that allows for safe contact.

NOTICE**INSUFFICIENT COOLING**

Failure to follow these instructions can result in equipment damage.

- Fill the cooling system with cooling water and with the specified additives prior to commissioning the product.
- Prior to starting the motor, operate the water cooling system and verify that it works properly and in accordance with the rated performance data.
- Verify that the heat dissipation is sufficient and that the specified climatic environmental conditions are respected by performing a test run under maximum load conditions.

Power on the power supply to the product via the main switch.

Check the following points during commissioning:

- Operating state, potential error conditions, and protective equipment
 - During commissioning, perform tests for all operating states and error conditions. In doing so, verify that all protective equipment operates as planned and required.
- Correct operation of the motor
 - There are no overloads.
 - There are no unusual fluctuations in the speed of rotation. Immediately stop the product in the case of overloads or unusual fluctuations in the speed of rotation and verify correct mounting.
- Noise emission
 - Excessive noise emission can be an indication of incorrect mounting, for example, an uneven ground that causes mechanical stress. Immediately stop the product in the case of high noise emission and verify correct mounting.
- Heat
 - Verify that the heat dissipation is sufficient and that the specified climatic environmental conditions are respected by performing a test run under maximum load conditions.

If the product and/or the machine into which the product is incorporated is temporarily decommissioned, it must be recommissioned. For recommissioning, the same prerequisites must be met as for initial commissioning.

Perform the same tests for each recommissioning of the product as for initial commissioning.

12 Operation

12.1 Basic information on operation



▲ WARNING

UNINTENDED EQUIPMENT OPERATION

Incorrect or unsuitable parameter values or settings can cause unintended movements, trigger signals, and compromise functional safety.

Failure to follow these instructions can result in death, serious injury, and equipment damage.

- Verify that parameter values and settings can only be modified by authorized personnel who fully understand each and every effect of such a modification.
- Verify that all parameter values and settings are correct by performing a test run.



▲ WARNING

UNANTICIPATED MOVEMENT OF THE OUTPUT FLANGE

If the holding brake becomes inoperative, the output flange can move even if the motor is at a standstill.

Failure to follow these instructions can result in death, serious injury, and equipment damage.

- Block or safeguard the output flange in such a way that a movement of the output flange is safely prevented before starting work on the output flange.



▲ WARNING

ELECTROMAGNETIC FIELDS

Failure to follow these instructions can result in death, serious injury, and equipment damage.



- Verify compliance with all international, national, and local directives, standards, and safety regulations, including all regulations concerning workplace safety and prevention of accidents, with regard to strong magnetic fields.
- Take all necessary measures to ensure that persons with active medical implants (such as heart pacemakers or insulin pumps), metal implants, and magnetically or electrically conductive objects are not exposed to do the magnetic fields generated by the product.
- Do not operate devices in the vicinity of the product which are sensitive to electromagnetic emission.
- Verify that a distance to the product of at least 15 cm is kept.

The product is a partly complete machine pursuant to Directive 2006/42/EU and intended to be incorporated into or assembled with other machinery. The information required for operation results from the functionality of the machine or system into which the product is incorporated and from the application implemented with it.

The instructions for the safe operation of the final machine or system must be provided by the system integrator (the person who incorporates the product in a machine pursuant to Directive 2006/42/EU) and/or the operator in the form of a manual with operating instructions, [see chapter 2.3](#).



These operating instructions must be a complete manual which describes all work on and with the product and which contains all information relevant to the product. The system integrator and/or operator must ensure compliance of the operating instructions with all applicable directives, regulations, and standards.

13 Troubleshooting

13.1 Issue, cause and remedy



⚠ DANGER

ELECTRIC SHOCK CAUSED BY LIVE PARTS

Failure to follow these instructions will result in death or serious injury.

- Disconnect the mains supply voltage before performing the work and ensure that it cannot be switched on.
- Verify that no hazards can be caused by electrically conductive objects.
- Verify that all cables for the power supply are disconnected from power.



⚠ WARNING

MOVING PARTS

Failure to follow these instructions can result in death, serious injury, and equipment damage.

- Verify that the zone of operation of the moving parts of the product/machine is safeguarded.



⚠ WARNING

HOT SURFACES

During operation, the product can reach a temperature of more than 80 °C.

Failure to follow these instructions can result in death, serious injury, and equipment damage.

- Before performing work on such parts, verify that you wait for a sufficient period of time to allow such parts to cool down to a temperature that allows for safe contact.

Issue	Cause	Remedy
Output flange does not rotate or does not reach the next position	No motor supply voltage	<ul style="list-style-type: none"> ▪ Check all fuses ▪ Check the motor protection switch
	Motor is inoperable	<ul style="list-style-type: none"> ▪ Contact the Weiss Service Department, see chapter 19.1
	Bearing is inoperable	
	The encoder is inoperative or defective	

14 Cleaning

14.1 Performing cleaning



⚠ DANGER

ELECTRIC SHOCK CAUSED BY LIVE PARTS

Failure to follow these instructions will result in death or serious injury.

- Disconnect the mains supply voltage before performing the work and ensure that it cannot be switched on.
- Verify that no hazards can be caused by electrically conductive objects.
- Verify that all cables for the power supply are disconnected from power.



⚠ WARNING

MISSING PROTECTIVE EQUIPMENT

Failure to follow these instructions can result in death, serious injury, and equipment damage.

- Immediately reinstall protective equipment that you may have removed to perform maintenance work after having completed the maintenance work and verify the effectiveness of the protective equipment.



⚠ WARNING

MOVING PARTS

Failure to follow these instructions can result in death, serious injury, and equipment damage.

- Verify that the zone of operation of the moving parts of the product/machine is safeguarded.



⚠ WARNING

HOT SURFACES

During operation, the product can reach a temperature of more than 80 °C.

Failure to follow these instructions can result in death, serious injury, and equipment damage.

- Before performing work on such parts, verify that you wait for a sufficient period of time to allow such parts to cool down to a temperature that allows for safe contact.

Cleaning

For cleaning of electrical components and additional components, respect the instructions in the documentations of the manufacturer; refer to the applicable documents.

Use the following cleaning agents for cleaning the product:

Component	Cleaning agents
Housing	Neutral, mildly alkaline
Output flange	
Stationary center part	

1. Remove fine impurities and dust with a dry, lint-free cloth.
2. Use a wet cloth and a neutral, mildly alkaline cleaning agent to remove stains on the housing and/or on the output flange and/or on the stationary center part.
3. Dry the cleaned areas.
4. Remove all equipment from the product.
5. Restore the readiness for operation of the product.

15 Maintenance

15.1 Maintenance plan

When	Activity
At least once per year or if required	<ul style="list-style-type: none"> ▪ Clean all surfaces of the product, see chapter 14.1
	<ul style="list-style-type: none"> ▪ Verify all screw connections of the product for correct tightening torque
	<ul style="list-style-type: none"> ▪ Verify correct connection of all plug connections

15.2 Lubricant

The product features lifetime lubrication.

Refer to the documentation of the manufacturer for information on the lubricants used; see applicable documents.

16 Decommissioning

16.1 Decommissioning the product

1. Switch off the product and secure it against unintended switching on.
2. Remove all workpieces and all other objects not belonging to the product from the product.
3. In the case of recommissioning, follow the instructions described, [see chapter 11](#).

17 Dismounting

17.1 Dismounting the product



▲ WARNING

FALLING, TOPPLING, OR LOWERING LOADS

Insufficiently rated load lifting and handling equipment may break. Transportation vehicles, lifting gear, chains, belts, and other equipment not rated for the product may fail or tilt.

Failure to follow these instructions can result in death, serious injury, and equipment damage.

- Only use transportation vehicles, lifting gear, chains, belts, and other lifting and handling equipment that comply with all applicable regulations and that are rated for the weight of the product including packaging.
- Verify that there are no persons in the danger zone.
- Verify that the product is properly secured against falling and toppling.

1. Switch off the supply voltage.
2. Dismount the product (reverse sequence of steps), [see chapter 8](#).

18 Disposal

18.1 Disposing of the product

Dispose of the product in compliance with all applicable directives, standards, and safety regulations.

Environmental protection

Dispose of lubricants, greases, residue of cleaning agents and other non-recyclable materials according to the applicable directives, standards, and safety regulations.

19 Service and spare parts

19.1 Worldwide service

If you need the assistance of our service departments, please provide the following information:

- Serial number of the product (see nameplate)
- Description of the problem
- Time of occurrence and circumstances of the problem
- Suspected cause

GERMANY

WEISS GmbH
Siemensstraße 17
74722 Buchen/Odenw.
Phone +49-6281-5208-5999
Fax +49-6281-5208-99
E-mail info@weiss-gmbh.de

SWITZERLAND

WEISS Schweiz GmbH
Friedhofstraße 7
2540 Grenchen
Phone +41-32-6536010
Fax +41-32-6536011
E-Mail info@weiss-gmbh.ch

NETHERLANDS

WEISS Nederland
Kruisstraat 4
7573 GJ Oldenzaal
Phone +31-541-853524
E-mail info@weiss-gmbh.nl

POLAND

WEISS Poland Sp. z o. o.
ul. Wielicka 250
30-663 Kraków
Phone +48-12-281-23-62
Fax +48-12-281-23-63
E-Mail info@weiss-poland.com

ITALY

WEISS Italia S.r.l.
Via dell'Arcoveggio 49/5
40129 Bologna
Phone +39-51-0474967
E-mail info@weiss-italia.it

USA | CANADA

WEISS North America, Inc.
3860 Ben Hur Avenue, Suite 3
Willoughby, OH 44094
Phone +1-888 WEISSNA (888-934-7762)
Fax +1-440-269-8036
E-mail info@weissna.com

SPAIN

WEISS España
Tecnología en máquinas especiales, S.L.
Avda. Juan Carlos I, N°13, 3°A „Torre Garena“
28806 Alcalá de Henares (Madrid)
Phone +34-91-830-06-86
Fax +34-91-830-06-87
E-mail info@weiss-gmbh.es

UNITED KINGDOM

WEISS UK Ltd.
Meridian House
Winsford Ind Estate
Winsford
Cheshire
CW7 3QG
Phone +44-1606-8605-67
E-mail info@weiss.uk.com

INDIA

WEISS Automation Solutions India Pvt. Ltd.
Office No. 101
Navale IT Park
Survey No. 51/2A/2
Nahre, Pune -411041
Phone +91-20-2469-9810
E-mail info@weiss-india.com

BRASIL

WEISS Brasil Ltda
Rod. BR 280 KM 43, n.º 501 - 3.º Pavimento,
Poço Grande, Guararirim - SC
Caixa Postal n.º 57 - Cep 89270 - 000
Phone +55-47-99914-9681 ou
+55-47-99971-1554
E-mail info@weiss-brasil.com

ASIA

WEISS Asia
Automation and Components Pte Ltd
18 Boon Lay Way
#07-112
TradeHub 21
Singapore 609966
Phone +65-6570-3274
Fax +65-6684-6757
E-mail info@weiss-asia.com

KOREA

WEISS Korea Co., Ltd.
213-ho, 448, Aenggogae-ro, Namdong-gu,
Incheon, Republic of Korea (21697)
Phone +82-32-228-5208
Fax +82-32-228-5209
E-mail sales@weiss-korea.com

CHINA

WEISS AUTOMATION TECHNOLOGY
(SHANGHAI) CO., LTD.
中国区总部/ Head Office in China
上海/ Shanghai
地址: 上海市嘉定区马陆镇思诚路
1250号8号楼
ADD: Building 8, No.1250 Sicheng Rd., Jiading
District
Phone +86-21-6076-7688 (总机 / Call Center)
Fax +86-21-6076-7699
E-mail info@weiss-china.com

19.2 Ordering spare parts



▲ WARNING

UNSUITABLE SPARE PARTS AND ACCESSORIES

Failure to follow these instructions can result in death, serious injury, and equipment damage.

- Only use spare parts and accessories which are approved by the manufacturer.

Please provide the following information when ordering spare parts:

- Serial number of the product (see nameplate)
- Part number of the spare part according to spare parts list
- Quantity of spare parts required



**INSPIRING PEOPLE
GREAT SOLUTIONS**

WEISS GmbH

Siemensstraße 17 74722 Buchen
Telefon 06281 5208-0 Telefax 06281 5208-99
info@weiss-international.com
www.weiss-international.com