

LINEAR MOTOR AXIS

HN0050A / HN0100A / HN0200A / HN0400A

MOUNTING INSTRUCTIONS

TD0002A-EN00-0000-00

022019_3.0_EN

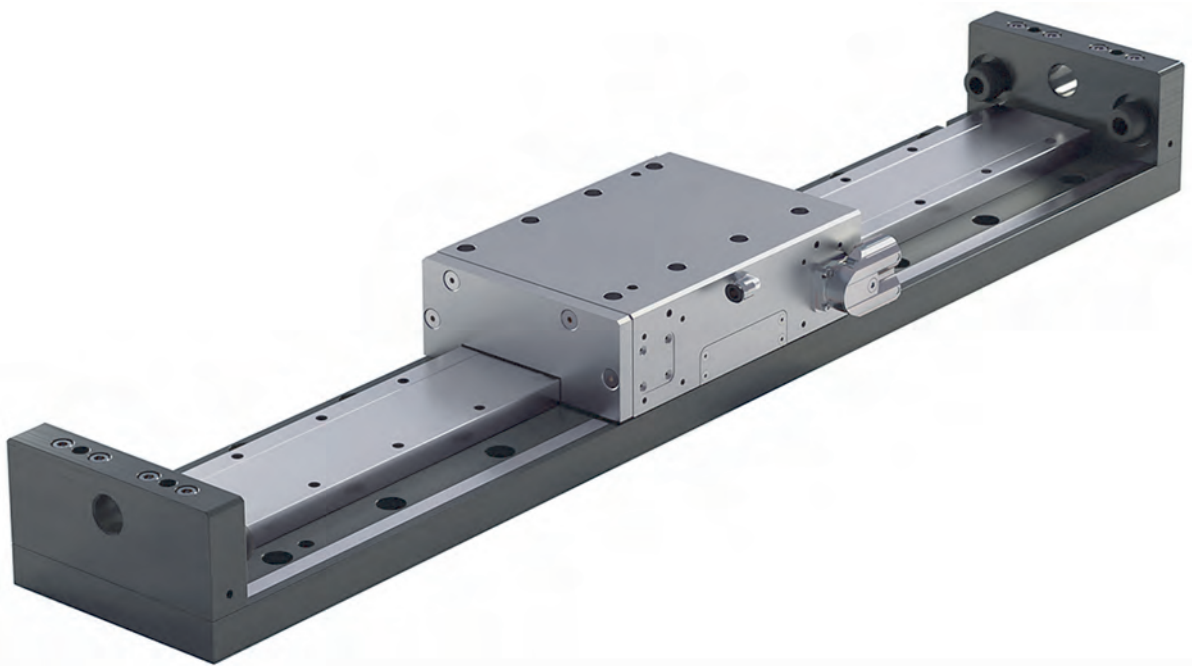

Table of contents

1	Introduction.....	5
1.1	About these mounting instructions.....	5
1.2	Intended use.....	5
1.3	Predictable incorrect application.....	6
1.4	Applicable documents.....	6
1.5	Warranty.....	7
2	Safety.....	8
2.1	Safety messages and hazard categories.....	8
2.2	Hazard symbols.....	9
2.3	Responsibilities of the system integrator and/or operator.....	9
2.4	Qualification of personnel.....	10
2.5	Hazards caused by strong magnetic fields.....	10
3	Product description.....	12
3.1	Overview.....	12
3.1.1	Overview "Automatic lubrication pump" (optional).....	13
3.2	Function description.....	13
3.3	Nameplate.....	14
3.4	Type code.....	14
3.5	Mounting positions.....	15
4	Technical data.....	16
4.1	General.....	16
4.2	Motor.....	16
4.3	Encoder.....	17
4.4	Inductive proximity switch.....	19
4.5	Climatic environmental conditions "Operation".....	19
4.6	Climatic environmental conditions "Transportation and Storage".....	19
4.7	Dimensions.....	20
4.7.1	Dimensions "Automatic lubrication pump" (optional).....	24
4.8	Load data.....	25
5	Packaging.....	27
5.1	Types of packaging.....	27
5.2	Unpacking the product.....	27
5.3	Verification of the delivery.....	28
6	Transportation.....	29
6.1	Transporting the product.....	29



6.2	Load lifting and handling equipment.....	30
6.3	Fastening the load lifting and handling equipment.....	30
7	Storage.....	33
7.1	Storing the product.....	33
8	Mounting.....	34
8.1	Prerequisites for mounting.....	34
8.2	Equipment and tools.....	34
8.3	Tightening torques and property classes.....	34
8.4	Bolting down the product.....	35
8.5	Connecting the lubrication hose (for optional automatic lubrication).....	37
8.6	Inverting the direction of the reference movement.....	37
8.7	Mounting additional components.....	38
8.8	Mounting safety equipment.....	38
9	Electrical connection.....	39
9.1	Connecting the protective ground conductor.....	40
9.2	Connection assignment.....	41
9.3	Connection assignment "Automatic lubrication pump" (optional).....	46
10	Controller.....	48
10.1	Basic information on control.....	48
10.2	WEISS GmbH controller/software package (optional).....	48
11	Commissioning.....	49
11.1	Prerequisites for commissioning.....	49
11.2	Performing commissioning.....	49
12	Operation.....	52
12.1	Basic information on operation.....	52
13	Troubleshooting.....	53
13.1	Issue, cause and remedy.....	53
14	Cleaning.....	55
14.1	Performing cleaning.....	55
15	Maintenance.....	57
15.1	Maintenance plan.....	57
15.2	Lubricant.....	58
15.3	Lubricating the product (manual lubrication).....	59
15.4	Replacing the grease cartridge at the automatic lubrication pump.....	60
15.5	Bleeding the lubrication hose.....	61
16	Decommissioning.....	62



16.1	Decommissioning the product.....	62
17	Dismounting.....	62
17.1	Dismounting the product.....	62
18	Disposal.....	62
18.1	Disposing of the product.....	62
19	Service and spare parts.....	63
19.1	Worldwide service.....	63
19.2	Ordering spare parts.....	64
19.3	Spare parts.....	64

1 Introduction

1.1 About these mounting instructions

These mounting instructions describe the product "Linear motor axis HN0050A / HN0100A / HN0200A / HN0400A" (also referred to as "product" in this document).

These mounting instructions are part of the product.

- You may only use the product if you have fully read and understood these mounting instructions.
- Verify that these mounting instructions are always accessible for any type of work performed on or with the product.
- Pass these mounting instructions as well as all other product-related documents on to all owners of the product.
- If you feel that these mounting instructions contain errors, inconsistencies, ambiguities or other issues, contact the manufacturer prior to using the product.

These mounting instructions are protected by copyright and may only be used as provided for by the corresponding copyright legislation. We reserve the right to modifications.

The manufacturer shall not be liable in any form whatsoever for direct or consequential damage resulting from failure to observe these mounting instructions or from failure to comply with directives, regulations and standards and any other statutory requirements applicable at the installation site of the product.

1.2 Intended use

The product is a partly complete machine pursuant to Directive 2006/42/EU, articles 1g and 2g. The product is only intended to be incorporated into or assembled with other machinery or other partly completed machinery or equipment, thereby forming machinery to which Directive 2006/42/EU applies.

The product may only be used within the limits specified in these mounting instructions and in the applicable documents. The applicable documents are also part of the product.

The machinery must not be put into service until the machinery into which the product has been incorporated has been determined and declared in conformity with the provisions of Directive 2006/42/EU and with all other applicable directives and regulations.

In addition, perform a risk assessment in view of the planned application, according to an approved risk assessment method, and implement the appropriate safety measures, based on the results of the risk assessment. Take into account the consequences of installing or integrating the product into a system or a plant.

When using the product, perform all work and all other activities in conjunction with the product in compliance with the conditions specified in the mounting instructions, in the applicable documents, and on the nameplate, as well as with all directives, standards, and safety regulations applicable at the installation site of the product.

1.3 Predictable incorrect application

Any use of the product beyond the explicitly indicated intended use is an impermissible, incorrect application of the product.

The product must never be used in the following cases, under the following conditions, and for the following purposes:

- Operation in residential environments
- Operation in life-supporting systems
- Operation in potentially explosive atmospheres/hazardous areas
- Operation on ships, in rail vehicles, land craft or in aircraft
- Operation in military facilities
- Operation outside of the specified order data
- Applications involving transportation of persons (fairground rides)

1.4 Applicable documents

In addition to these mounting instructions, the following documents are binding for and apply to any type of use of the product:

- Order data (including, but not limited to, design data, load data, performance data, transportation and storage instructions, information attached to the product and the package, as well as other specifications).
- Documentations of the manufacturers of all products belonging to the scope of delivery (for example, motor, accessories, attachment parts).

Type of manual	Type	Manufacturer	Delivery	
			Paper format	Electronic
Data sheet	Inductive proximity switch BES R04KC-PSC15B-EP00,13-GS49	Balluff GmbH	-	X
Operating instructions	Encoder BML-S1F...	Balluff GmbH	-	X
Operating instructions	Encoder BML-S1G...	Balluff GmbH	-	X
Operating instructions	Encoder BML-S1H...	Balluff GmbH	-	X
Safety data sheet	Lubricant LE-Spezialfett Synt EP 2	HERM GmbH & Co. KG	-	X
In the case of delivery with WEISS GmbH controller/software package:			Delivery	
			Paper format	Electronic
User manual	"W.A.S. 2 COMPACT" TD0079A-XX00-0000-00	WEISS GmbH	-	X



In the case of delivery with WEISS GmbH controller/software package:			Delivery	
			Paper format	Electronic
User manual	"W.A.S. 2 SCALABLE" TD0081A-XX00-0000-00	WEISS GmbH	-	X
Electrical documenta- tion	List of applicable documents, per product (see documents on the CD delivered with the product)	WEISS GmbH	-	X

1.5 Warranty

See our website for our General Terms and Conditions at www.weiss-international.com or your purchase order.

2 Safety

2.1 Safety messages and hazard categories

These mounting instructions contain safety messages to alert you to potential hazards and risks. Safety messages in these mounting instructions are highlighted with warning symbols and warning words.

The signal word describes the source of the hazard. The text contains instructions on how to avoid the hazard as well as the consequence resulting from failure to follow the instructions given in the safety message.

Depending on the severity of a hazard, the safety messages are classified according to different hazard categories.



⚠ DANGER

DANGER indicates an immediately hazardous situation, which, if not avoided, will result in death or serious injury.



⚠ WARNING

WARNING indicates a hazardous situation, which, if not avoided, can result in death or serious injury or equipment damage.



⚠ CAUTION

CAUTION indicates a hazardous situation, which, if not avoided, can result in injury or equipment damage.

NOTICE

NOTICE indicates a hazardous situation, which, if not avoided, can result in equipment damage.

In addition to the instructions and safety messages provided in these mounting instructions, you must comply with all directives, standards, and safety regulations applicable at the installation site of the product.

2.2 Hazard symbols

The following symbols are used in these mounting instructions:



This is the general safety alert symbol. It alerts to injury hazards or equipment damage. Comply with all safety instructions in conjunction with this symbol to help avoid possible death, injury, or equipment damage.



This symbol alerts to hazardous electrical voltage. If this symbol is used in a safety message, there is a hazard of electric shock.

Hazard symbols may also be attached to the product.



Hazard of hot surface



Hazard of magnetic field



No access for persons with heart pacemakers or other medical implants

2.3 Responsibilities of the system integrator and/or operator

The system integrator (the person who incorporates the product in a machine pursuant to Directive 2006/42/EU, i.e., for example, the machine builder) and/or the operator must ensure the following:

- The application and use of the product must be limited to the specified intended use.
- In the integration of the product, all functional safety requirements must be met.
- All directives, standards, and safety regulations, including all regulations concerning workplace safety and prevention of accidents, applicable at the installation site of the product must be complied with.
- Any type of work whatsoever on and with the product may only be performed by qualified personnel.
- The product may only be operated when it is in flawless, fully functional condition.
- All safety equipment must operate as required and planned.
- The personal protective equipment for the personnel/operator must be available and must be used.
- The mounting instructions and all applicable documents must always be accessible in their entirety to the personnel at the installation site of the product.
- Safety instructions, labels, and any other information attached to the product must not be removed.
- A complete manual must be available for the machine into which the product is incorporated; this manual must describe all types of work on and with the machine and contain all information relevant with regard to the product.

If the system integrator himself is not in the position to comply with any of these obligations, the system integrator must impose compliance with these obligations on the operator.

2.4 Qualification of personnel

Only trained personnel who have fully read and understood the mounting instructions and all applicable documents for the product may perform work on and with the product.

This trained personnel must have sufficient technical training, knowledge, and experience, and be able to foresee and detect potential hazards that may be caused by using the product.

All trained personnel working on and with the product must be fully familiar with all directives, standards, and safety regulations that must be observed for performing such work.

2.5 Hazards caused by strong magnetic fields

The magnetic attraction of the motor components containing permanent magnets increases with decreasing distance and can be higher than several kN in the hazardous exposure range (distance less than 100 mm).



⚠ DANGER

ELECTRIC SHOCK

Each movement of electrically conductive materials vis à vis permanent magnets results in inductive voltage.

Failure to follow these instructions will result in death or serious injury.

- Avoid any movement of components with permanent magnets vis à vis electrically conductive materials in vice versa.



⚠ WARNING

ELECTROMAGNETIC FIELDS

Failure to follow these instructions can result in death, serious injury, and equipment damage.



- Verify compliance with all international, national, and local directives, standards, and safety regulations, including all regulations concerning workplace safety and prevention of accidents, with regard to strong magnetic fields.
- Take all necessary measures to ensure that persons with active medical implants (such as heart pacemakers or insulin pumps), metal implants, and magnetically or electrically conductive objects are not exposed to do the magnetic fields generated by the product.
- Do not operate devices in the vicinity of the product which are sensitive to electromagnetic emission.
- Verify that a distance to the product of at least 15 cm is kept.

**⚠ WARNING****FORCES OF ATTRACTION ACTING ON MAGNETIZABLE MATERIALS**

Failure to follow these instructions can result in death, serious injury, and equipment damage.

- Verify that you do not move objects consisting of magnetizable materials (such as watches, steel or iron tools) and/or permanent magnets into the hazardous exposure range of a component containing a permanent magnet.
- The following must be available to free trapped parts of the body in case of accidents during work with permanent magnets:
 - Hammer (approx. 3 kg) made of solid, non-magnetizable material
 - Two pointed wedges (wedge angle approx. 10 ° to 15 °) made of solid, non-magnetizable material

NOTICE**LOSS OF DATA AND DAMAGE TO ELECTRONIC EQUIPMENT**

Failure to follow these instructions can result in equipment damage.

- Do not allow electronic devices which are sensitive to magnetic attraction forces in the vicinity of the product.

3 Product description

3.1 Overview

The product consists of the following components:

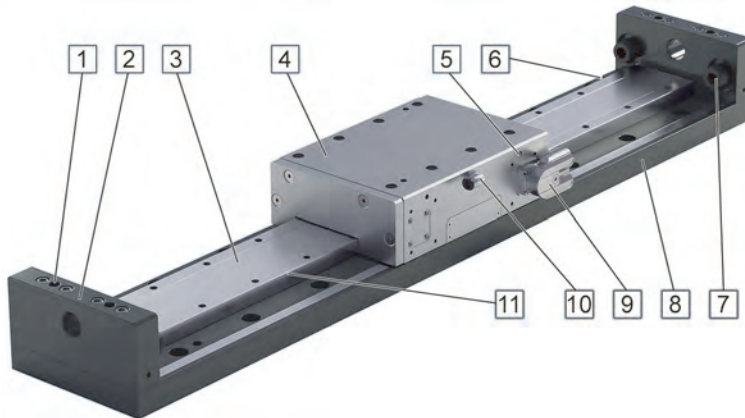

- | | | | |
|----------|--|-----------|--------------------------------------|
| 1 | Hole for load lifting and handling equipment | 7 | Stop buffers |
| 2 | Limit stops | 8 | Base plate with scale |
| 3 | Magnet way | 9 | Connection motor cable/encoder cable |
| 4 | Drive carriage/primary | 10 | Lubrication connection |
| 5 | Connection protective ground conductor | 11 | Guide rail |
| 6 | Inductive reference switch (only with incremental encoder) | | |

3.1.1 Overview "Automatic lubrication pump" (optional)

The automatic lubrication pump consists of the following components:

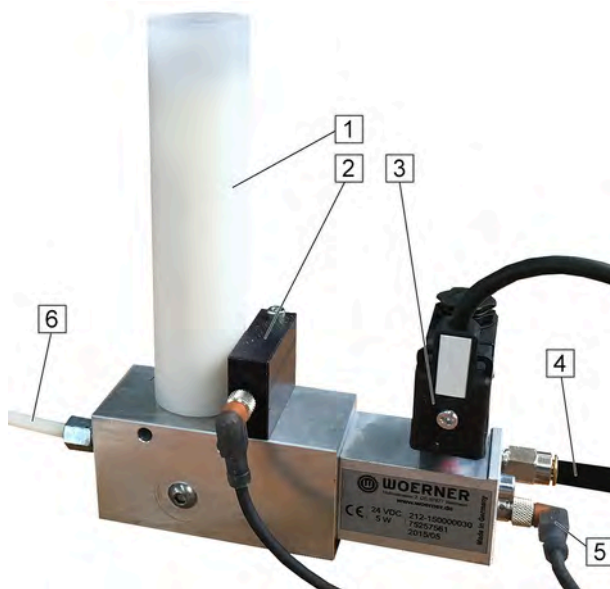

- | | | | |
|---|------------------|---|---|
| 1 | Grease cartridge | 4 | Pneumatic supply |
| 2 | Level sensor | 5 | Function monitoring |
| 3 | Pneumatic valve | 6 | Lubrication hose (optionally available with two lubrication hose connections) |

3.2 Function description

The drive carriage performs linear movements along the specified stroke lengths. The product is available in different versions (stroke lengths).

The motor of the product is controlled by a servo drive. The integrated encoder provides for high positioning accuracy and repeatability.

To reduce the maintenance, the product can be equipped with an optional automatic lubrication pump.

For commissioning, parameterization and diagnostics, the product can be operated with the WEISS Application Software (W.A.S. 2).

3.3 Nameplate

The nameplate is attached to the drive carriage/primary of the product; it contains the following information:

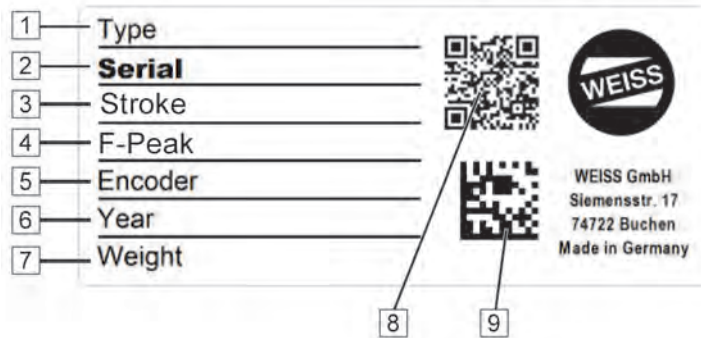

Figure 1: Example of nameplate

- | | | | |
|---|---------------|---|---------------------------|
| 1 | Type | 6 | Year of manufacture |
| 2 | Serial number | 7 | Weight |
| 3 | Stroke length | 8 | QR code (company website) |
| 4 | Peak force | 9 | DM code (serial number) |
| 5 | Encoder | | |

The scope of delivery contains a second nameplate. If the factory-mounted nameplate is covered by attachments, the second nameplate can be attached at a readily visible position of the product or machine for identification of the product.

3.4 Type code

Structure of the type code:

Type	Size	Encoder	Plug connection	Holding brake
HN	0050A 0100A 0200A 0400A	A (Incremental) B (Absolute BiSS) C (Absolute SSI)	A (right) B (left)	A (without holding brake) B (with holding brake)

3.5 Mounting positions

NOTICE

EQUIPMENT DAMAGE DUE TO INCORRECT MOUNTING POSITION

Failure to follow these instructions can result in equipment damage.

- Verify that you only use the standard mounting positions approved in these mounting instructions.
- Only use special mounting positions if such special mounting positions have been approved by the manufacturer in writing.

Permissible standard mounting positions

The product may only be mounted as shown below.



Horizontal



Upside down



Vertical



At any angle

4 Technical data

4.1 General

Characteristic	Unit	Value			
		HN0050A	HN0100A	HN0200A	HN0400A
Nominal force	N	65	150	250	500
Peak force	N	180	380	700	1400
Maximum velocity	m/s	4			
Maximum acceleration	m/s ²	40			
Maximum payload	kg	15	25	50	100
Repeatability (at a constant temperature of 20 °C)	µm	5			
Temperature sensor	-	PTC switch			
Weight	kg	See nameplate			
Total weight including packaging	kg	See bill of delivery			
Sound pressure	dB(A)	< 70			
Lubricant	-	LE-Spezialfett Synt EP 2			

4.2 Motor

Characteristic	Unit	Value			
		HN0050A	HN0100A	HN0200A	HN0400A
Pole width	mm	27.6	26	30	30
Nominal voltage	V DC	600			
Maximum DC bus voltage	V DC	800			
Voltage constant (rms)	V/(m/s)	23	33	47	69
Maximum acceleration	m/s ²	40			
Nominal velocity	m/s	4			
Maximum velocity	m/s	5	4	4	4
Nominal force	N	65	150	250	500
Peak force	N	180	380	700	1400
Force constant	N/A	35	43	62.2	93
Nominal current	A	2.4	3.6	4.5	5
Peak current	A	6	9.5	11.2	15
Winding cross section	mm ²	0.176	0.2827	0.1964	0.5655



Characteristic	Unit	Value			
Stator resistance at 20°C*	Ohm	7.5	8	5.8	4.6
Stator inductance*	Henry	0.0212	0.048	0.046	0.039
Rotor mass	kg	2.2	4.7	8.1	13.4

* Measured between phase and phase (star connection)

4.3 Encoder

Refer to the documentation of the manufacturer for the technical data of the additional encoder; see applicable documents.

Incremental

Characteristic	Unit	Value
		Balluff BML-S1F
Supply voltage	V	5 ± 5 %
Incremental signals	V _{pp}	sin/cos 1
Signal period	mm	1
Reference mark	-	Without
Accuracy	µm/m	± 10

Absolute BiSS

Characteristic	Unit	Value		
		Balluff BML-S1H - 19 bits	Balluff BML-S1H - 20 bits	Balluff BML-S1G - 32 bits
Supply voltage	V	5 ± 5 %		
Absolute signals	-	BiSS		
Measuring length	mm	500	1000	± 8000
Resolution	/mm	1024	1024	1000
SSI cycle frequency	-	100 kHz ...4 MHz	70 kHz ...900 kHz	70 kHz ...900 kHz
Coding	-	Binary code		
CRC	-	6		
CRC numerator polynomial	hex / dec	0 x 43 / 67		
Number of data bits	-	19	20	32 (28)
Number of error bits	-	0	0	1+1
Number of zero bits	-	2	2	0 (4)

Characteristic	Unit	Value		
Order of data	-	Position: 19 Zero bit: 2 CRC: 6	Position: 20 Zero bit: 2 CRC: 6	(zero bit: 4) Position: 32 (28) Error bit: 1 Warning: 1 CRC: 6
Incremental signals	V _{pp}	sin/cos 1		
Signal period	mm	1	1	2

Absolute SSI

Characteristic	Unit	Value					
		Balluff BML-S1H - 19 bits	Balluff BML-S1H - 19 bits	Balluff BML-S1H - 20 bits	Balluff BML-S1H - 20 bits	Balluff BML-S1G - 23 bits	Balluff BML-S1G - 24 bits
Option		Parameterization BOSCH	Parameterization Siemens	Parameterization BOSCH	Parameterization Siemens	-	-
Supply voltage	V	5 ± 5 %					
Absolute signals	-	SSI					
Measuring length	mm	500	500	1000	1000	± 4000	± 8000
Resolution	/mm	1024	1024	1024	1024	1000	
SSI cycle frequency	kHz	400	100	400	100	70...900	
Monoflop time	µs	4	16	4	16	Automatic	
Coding	-	Binary code					
Number of data bits	-	19	19	20	20	23	24
Number of error bits	-	0	0	0	0	1	1
Number of zero bits	-	2	2	2	2	1	1
Order of data	-	Position: 19 Zero bit: 2	Position: 19 Zero bit: 2	Position: 20 Zero bit: 2	Position: 20 Zero bit: 2	Position: 23 Zero bit: 1 Error: 1	Position: 24 Zero bit: 1 Error: 1
Incremental signals	V _{pp}	sin/cos 1					
Signal period	mm	1	1	1	1	2	

4.4 Inductive proximity switch

Refer to the documentation of the manufacturer for the technical data of the proximity switch; see applicable documents.

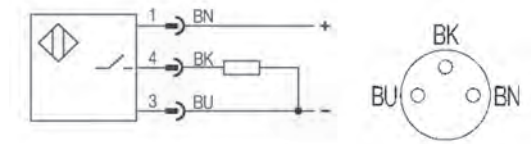

Figure 2: Connection diagram

4.5 Climatic environmental conditions "Operation"

Characteristic	Unit	Value
Ambient temperature	° C	+15 ... +45
Relative humidity, non-condensing	%	+5 ... +95
Maximum surface temperature	° C	80
Maximum installation altitude above mean sea level	m	1000

4.6 Climatic environmental conditions "Transportation and Storage"

Characteristic	Unit	Value
Ambient temperature	° C	+5 ... +55
Relative humidity, non-condensing	%	+5 ... +95
Maximum storage duration of the mechanical components	-	see chapter 7

4.7 Dimensions

Product type: HN0050A

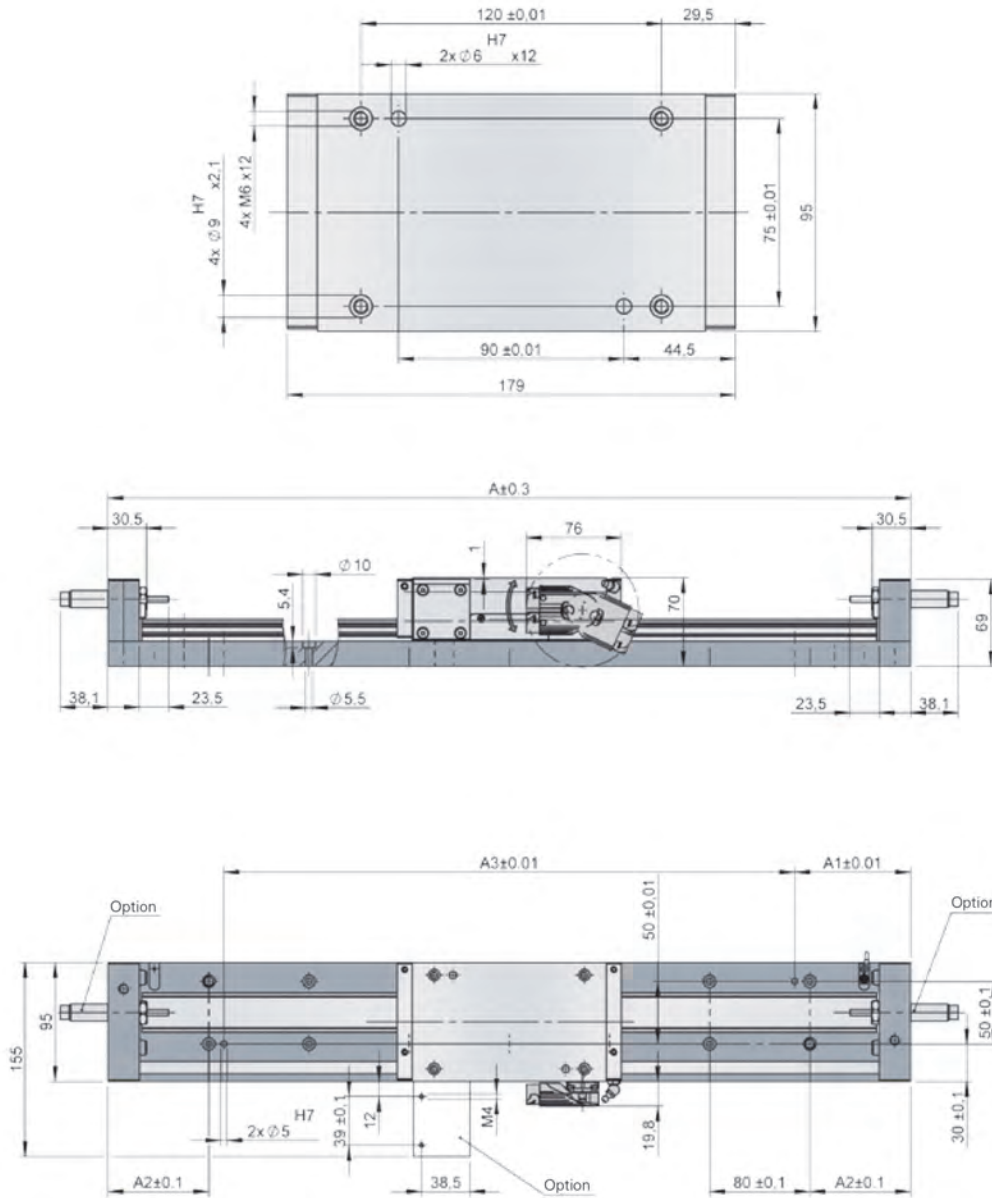

Figure 3: Lengths and diameters in mm

Example stroke	A	A1	A2	A3
1000 mm	1241 mm	72.5 mm	60.5 mm	1096 mm

Available strokes starting at 100 mm, in increments of 100 mm up to 1000 mm.

Product type: HN0100A

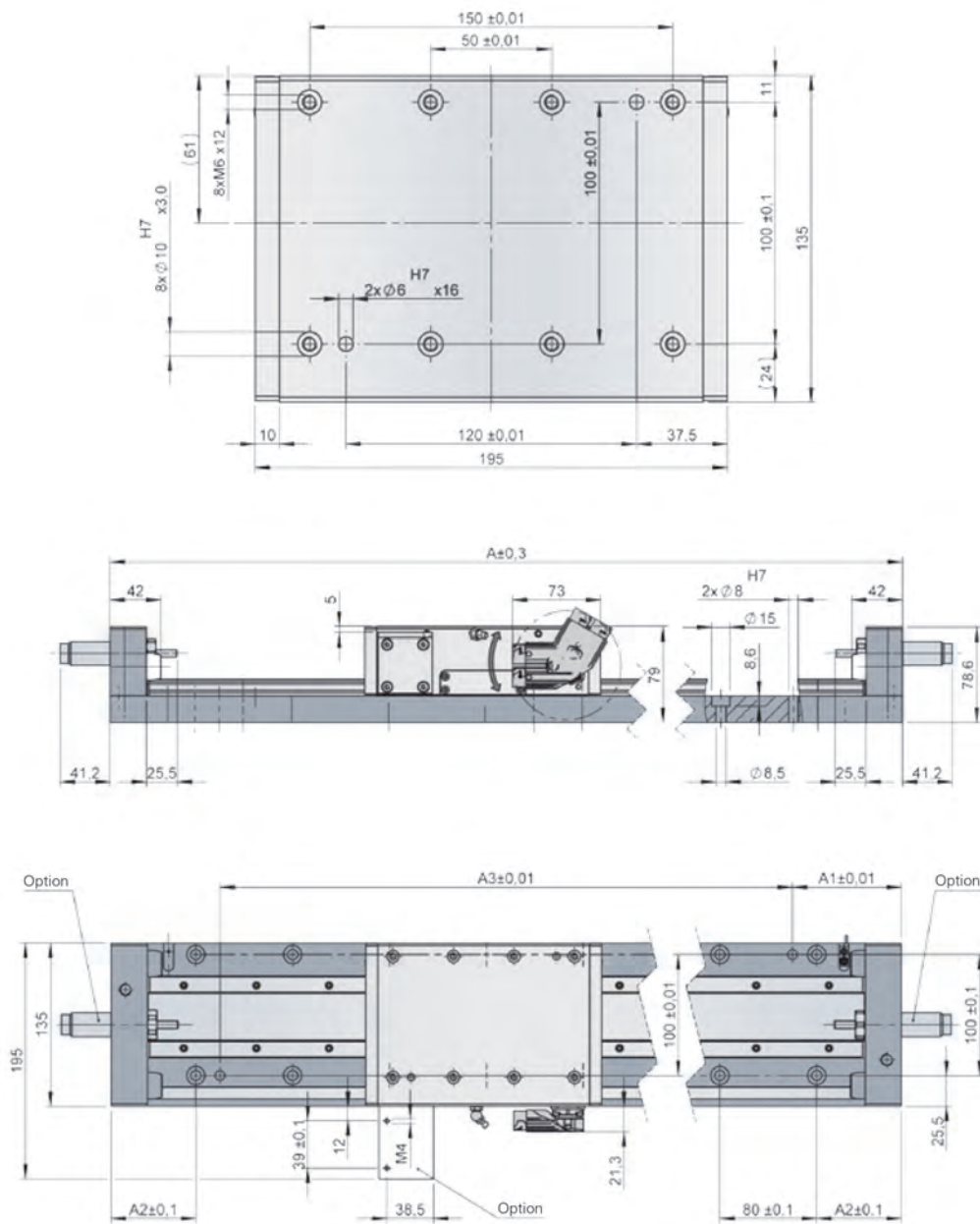

Figure 4: Lengths and diameters in mm

Example stroke	A	A1	A2	A3
1000 mm	1280 mm	140 mm	80 mm	1000 mm

Available strokes starting at 100 mm, in increments of 100 mm up to 2000 mm.

Product type: HN0200A

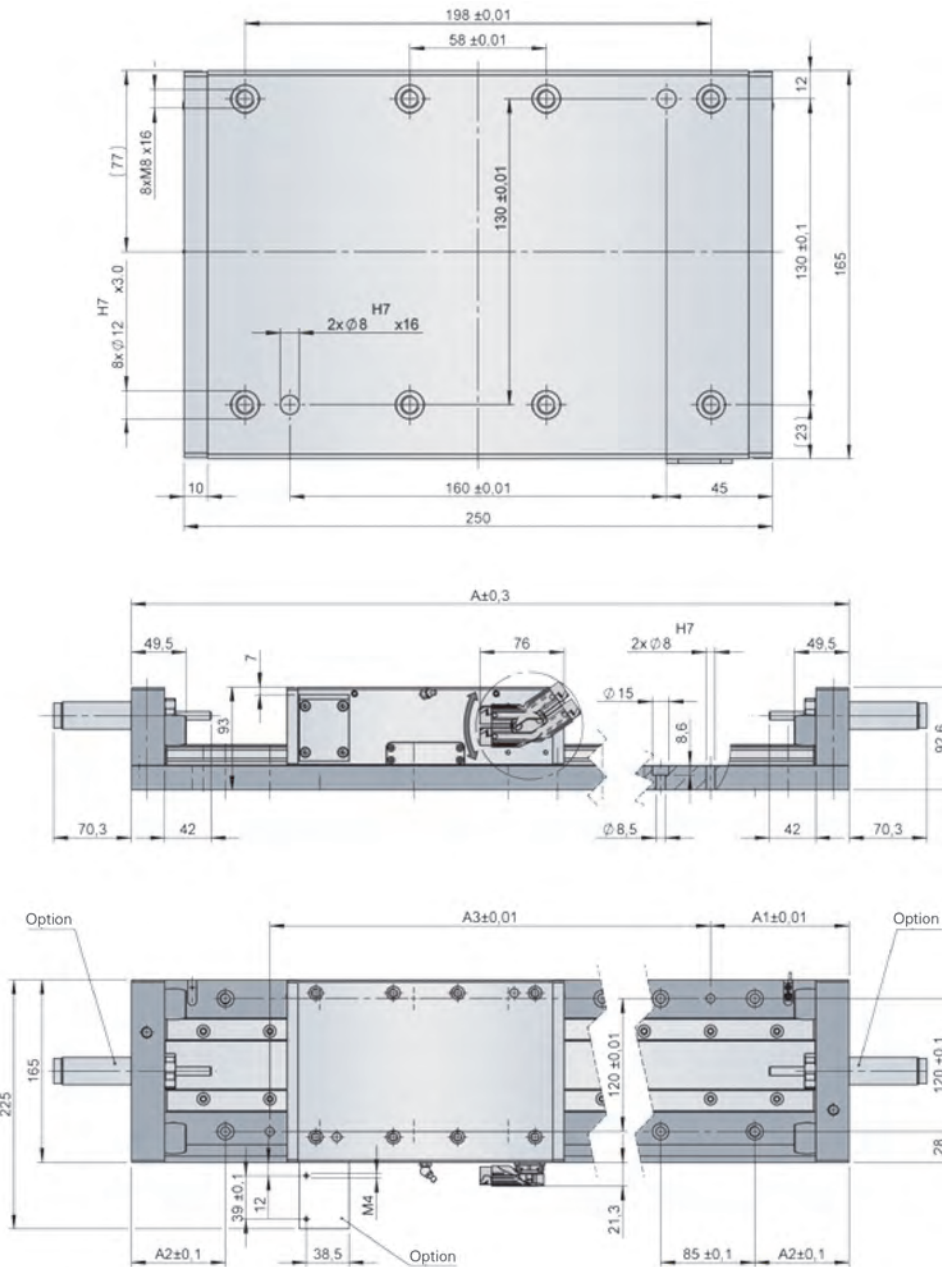

Figure 5: Lengths and diameters in mm

Example stroke	A	A1	A2	A3
1000 mm	1350 mm	125 mm	80 mm	1100 mm

Available strokes starting at 100 mm, in increments of 100 mm up to 2000 mm.

Product type: HN0400A

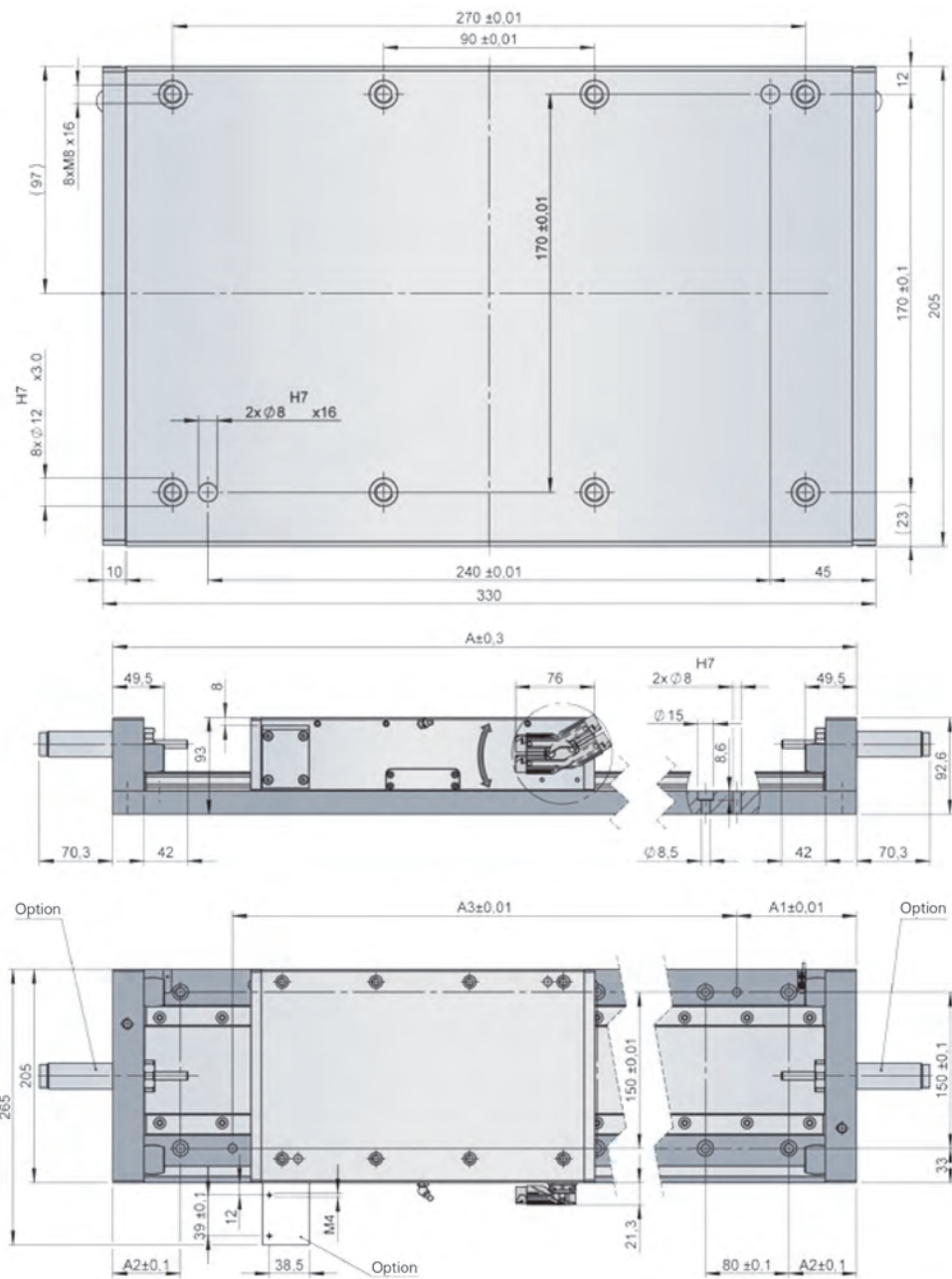

Figure 6: Lengths and diameters in mm

Example stroke	A	A1	A2	A3
1000 mm	1430 mm	115 mm	75 mm	1200 mm

Available strokes starting at 100 mm, in increments of 100 mm up to 2000 mm.

4.7.1 Dimensions "Automatic lubrication pump" (optional)

With one lubrication hose connection

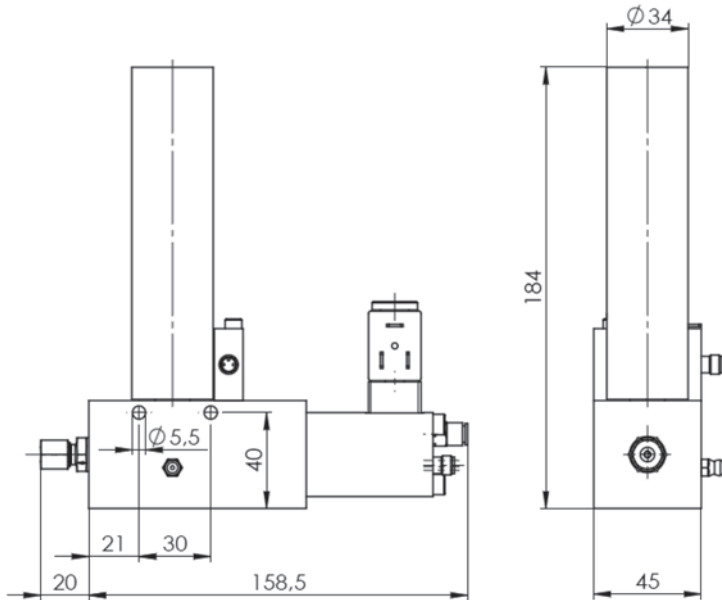

Figure 7: Lengths and diameters in mm

With two lubrication hose connections

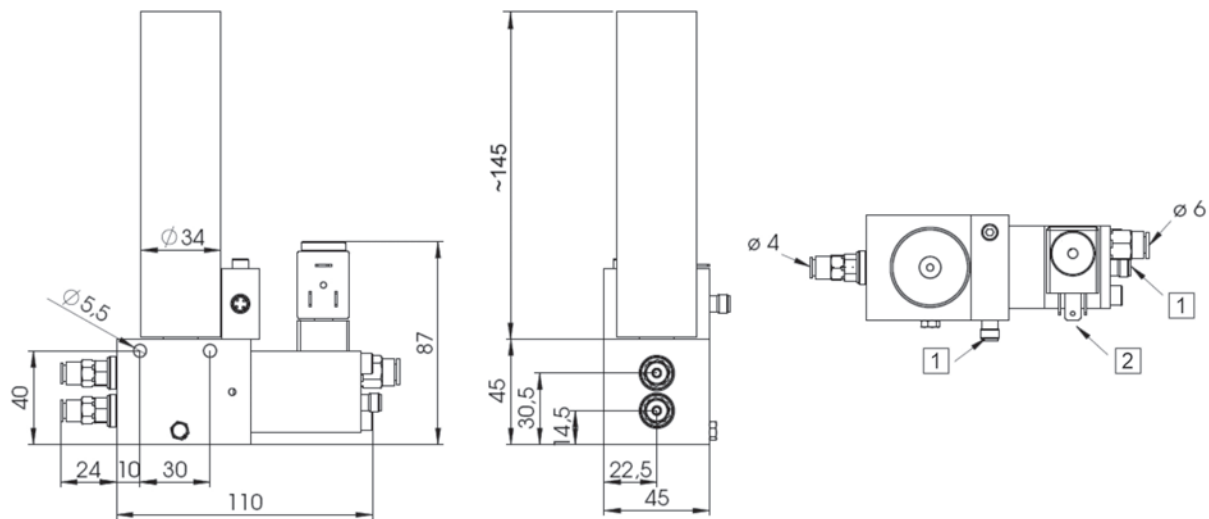





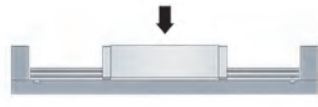

Figure 8: Lengths and diameters in mm

1 M8 - 3-pin





2 Valve, type B

4.8 Load data

Static load data

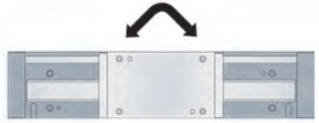
Representation	Unit	Value			
		HN0050A	HN0100A	HN0200A	HN0400A
	Nm	200	350	500	1000
	Nm	200	350	500	1000
	Nm	50	100	200	500
	N	500	750	1000	1500
	N	250	500	750	1000

Dynamic load data

Representation	Unit	Value			
		HN0050A	HN0100A	HN0200A	HN0400A
	Nm	20	40	80	140
	Nm	20	40	80	140
	Nm	10	15	40	60
	N	150	250	500	1000
	N	100	150	250	500

5 Packaging

5.1 Types of packaging



Packaging in Europe

The product is factory-packaged in film and screwed onto a pallet. The pallet is packaged in a cardboard box.



Packaging for air and sea freight

The product is factory-treated with anti-corrosion agent, packaged in Corpac-coex-VCI film, screwed onto a pallet, and then packed into a wooden box with foam plastic material.

5.2 Unpacking the product

1. Do not remove the packaging until immediately prior to mounting.
2. Dispose of the packaging material in compliance with all directives, standards, and safety regulations applicable at the installation site.

5.3 Verification of the delivery

- Check the delivery for completeness and transportation damage upon reception.
- In the case of damage, reject the delivery or accept it only conditionally.
- Document the damage in the transportation documents/bill of delivery (any damage detected must be immediately reported to the forwarding agent and confirmed by the forwarding agent).
- Take photographs of the damage.
- Report the damage to WEISS GmbH.

6 Transportation



▲ WARNING

FALLING, TOPPLING, OR LOWERING LOADS

Insufficiently rated load lifting and handling equipment may break. Transportation vehicles, lifting gear, chains, belts, and other equipment not rated for the product may fail or tilt.

Failure to follow these instructions can result in death, serious injury, and equipment damage.

- Only use transportation vehicles, lifting gear, chains, belts, and other lifting and handling equipment that comply with all applicable regulations and that are rated for the weight of the product including packaging.
- Verify that there are no persons in the danger zone.
- Verify that the product is properly secured against falling and toppling.

6.1 Transporting the product

Packages fastened to a pallet can be transported with a fork lift truck, a pallet jack or similar transportation means. Verify that the transportation means used is suitable and approved for the weight and the dimensions of the package.



1. Place the forks below the pallet.
2. Verify that the pallet with the package fully rests on the forks.
3. Fasten the pallet with the package using additional straps if the center of gravity is not in the center of the pallet.

6.2 Load lifting and handling equipment



Use properly rated load lifting and handling equipment and hoisting belts/hoisting equipment for transporting the product. Eyebolts must not be used as load lifting and handling equipment.

6.3 Fastening the load lifting and handling equipment



⚠ WARNING

ELECTROMAGNETIC FIELDS

Failure to follow these instructions can result in death, serious injury, and equipment damage.



- Verify compliance with all international, national, and local directives, standards, and safety regulations, including all regulations concerning workplace safety and prevention of accidents, with regard to strong magnetic fields.
- Take all necessary measures to ensure that persons with active medical implants (such as heart pacemakers or insulin pumps), metal implants, and magnetically or electrically conductive objects are not exposed to do the magnetic fields generated by the product.
- Do not operate devices in the vicinity of the product which are sensitive to electromagnetic emission.
- Verify that a distance to the product of at least 15 cm is kept.



⚠ CAUTION

STRONG MAGNETIC FIELDS

The permanent magnets of the magnet way generate magnetic fields. The magnetic attraction forces considerably increase in the range of hazardous exposure (distance of less than 100 mm). Magnetizable materials, but also the linear motor axes, are attracted with high forces.

Failure to follow these instructions can result in injury or equipment damage.

- Transport and store the products separately.
- Do not stack the products.
- Verify that separating tools are available for emergencies.

NOTICE

HARMFUL EXTERNAL INFLUENCES

Failure to follow these instructions can result in equipment damage.

- Verify that the magnet way does not come into contact with magnetized objects.
- Do not subject the magnet way to mechanical impact.
- If you mount several products, avoid any contact between the magnet ways of the products.

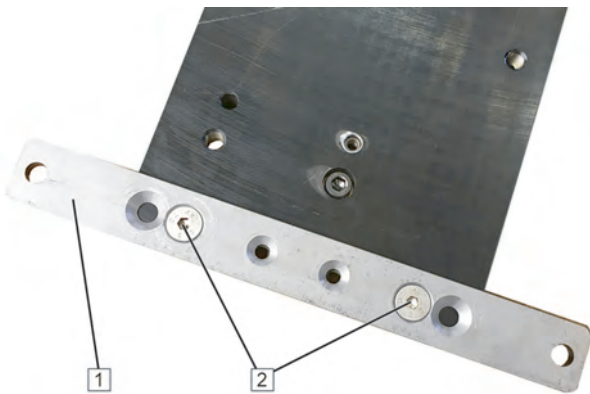

1. Remove the screws of the two packaging bars [1] used to fasten the product to the palette.
2. Remove the two packaging bars [1] from the product by removing the screws [2] at the underside of the product.

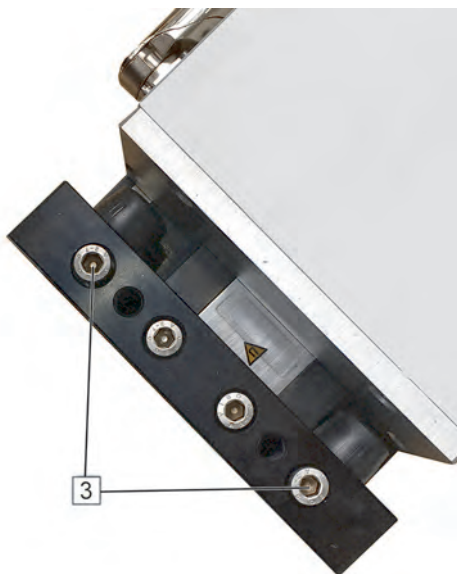

3. Tighten the two screws [3] at the limit stop.

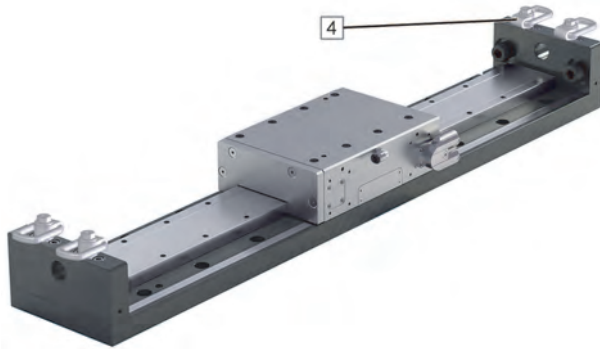

4. Use properly rated load lifting and handling equipment and hoisting belts/hoisting equipment for transporting the product.
5. Screw the load lifting and handling equipment [4] into the outer threads of the limit stops.
6. Fasten the hoisting belts or the hoisting equipment to the eyelets of the load lifting or load handling equipment.

7 Storage

7.1 Storing the product



⚠ CAUTION

STRONG MAGNETIC FIELDS

The permanent magnets of the magnet way generate magnetic fields. The magnetic attraction forces considerably increase in the range of hazardous exposure (distance of less than 100 mm). Magnetizable materials, but also the linear motor axes, are attracted with high forces.

Failure to follow these instructions can result in injury or equipment damage.

- Transport and store the products separately.
- Do not stack the products.
- Verify that separating tools are available for emergencies.

NOTICE

INCORRECT STORAGE

Failure to follow these instructions can result in equipment damage.

- Verify compliance with all conditions specified in these mounting instructions and all applicable documents when storing the product.

The mechanical components of the product can be stored for a period of up to two years.

Conditions for the specified maximum storage duration:

- Storage in original packaging
- Compliance with all specified storage conditions
- Storage in suitable closed, dry, dust-free room, protected against direct sunlight
- No contact with corrosive media
- Corrosion protection intact

The electrical components (for example, the encoder) have a different maximum storage duration (see documentations of the manufacturers).

If the maximum storage duration has been exceeded, you must contact the manufacturer prior to commissioning the product. This also applies if the machine in which the product has been incorporated has not been operated for a period of time exceeding the maximum storage durations specified for the mechanical and electrical components.

If you plan to store the product for a period of time exceeding the maximum permissible storage duration specified for the mechanical components, you must uninstall the electrical components prior to storing the product. The electrical components must be stored according to the specifications of the manufacturers (see documentations of the manufacturers).

If the product is to be stored for a period of more than three months, the product must first be preserved. If the factory-applied anti-corrosion agent is no longer intact, you must request preservation instructions from the manufacturer.

8 Mounting

8.1 Prerequisites for mounting

Prior to mounting, verify that the dimensions of the installation site and construction conditions meet the requirements and the dimensions specified in these mounting instructions and the applicable documents.

- Verify that the supporting base is level and rigid.
- Verify that the supporting structure at the installation site has a sufficient structural strength to carry the weight of the product and of all loads.
- Inspect the holes with the drilling template of the product, [see chapter 4.7](#).
- Prepare the screws and the mounting tools.

8.2 Equipment and tools



⚠ CAUTION

STRONG MAGNETIC FIELDS

The permanent magnets of the magnet way generate magnetic fields. The magnetic attraction forces considerably increase in the range of hazardous exposure (distance of less than 100 mm). Magnetizable materials are attracted with high forces.

Failure to follow these instructions can result in injury or equipment damage.

- Only use non-magnetic tools.

The following is required for mounting:

- Set of hex keys
- Torque wrench
- Cotter pin punch (for mounting the parallel pins)
- Ball pane hammer

8.3 Tightening torques and property classes

Only use screws with the property class shown in the following table unless a different property class is explicitly specified for a screw connection.

Use the tightening torque shown in the following table unless a different tightening torque is explicitly specified for a screw connection.

Property class of screws	10.9 (coefficient of friction μ_{tot} 0.12)			
Thread	M5	M6	M8	M10
Tightening torque	8 Nm	14 Nm	34 Nm	68 Nm

8.4 Bolting down the product



⚠ WARNING

FALLING, TOPPLING, OR LOWERING LOADS

Insufficiently rated load lifting and handling equipment may break. Transportation vehicles, lifting gear, chains, belts, and other equipment not rated for the product may fail or tilt.

Failure to follow these instructions can result in death, serious injury, and equipment damage.

- Only use transportation vehicles, lifting gear, chains, belts, and other lifting and handling equipment that comply with all applicable regulations and that are rated for the weight of the product including packaging.
- Verify that there are no persons in the danger zone.
- Verify that the product is properly secured against falling and toppling.



⚠ WARNING

ELECTROMAGNETIC FIELDS

Failure to follow these instructions can result in death, serious injury, and equipment damage.



- Verify compliance with all international, national, and local directives, standards, and safety regulations, including all regulations concerning workplace safety and prevention of accidents, with regard to strong magnetic fields.
- Take all necessary measures to ensure that persons with active medical implants (such as heart pacemakers or insulin pumps), metal implants, and magnetically or electrically conductive objects are not exposed to do the magnetic fields generated by the product.
- Do not operate devices in the vicinity of the product which are sensitive to electromagnetic emission.
- Verify that a distance to the product of at least 15 cm is kept.



⚠ WARNING

IMPROPERLY FASTENED PARTS

Failure to follow these instructions can result in death, serious injury, and equipment damage.

- Verify that the supporting structure and/or the frame and/or the mounting surface for fastening the product are sufficiently rated to withstand all static and dynamic loads and forces during operation.
- Verify that the fastening parts comply with the specifications indicated and that they are sufficiently rated for all load conditions during operation.

NOTICE**HARMFUL EXTERNAL INFLUENCES**

Failure to follow these instructions can result in equipment damage.

- Verify that the magnet way does not come into contact with magnetized objects.
- Do not subject the magnet way to mechanical impact.
- If you mount several products, avoid any contact between the magnet ways of the products.

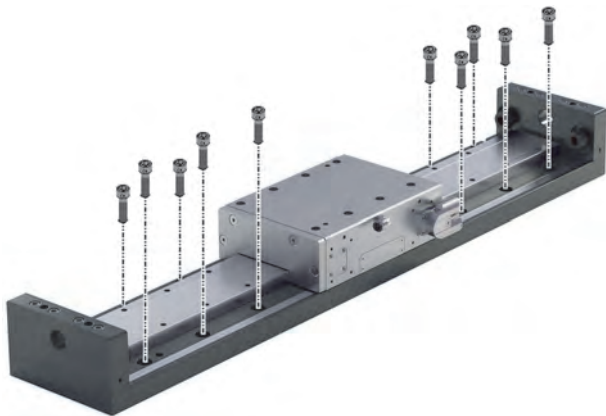
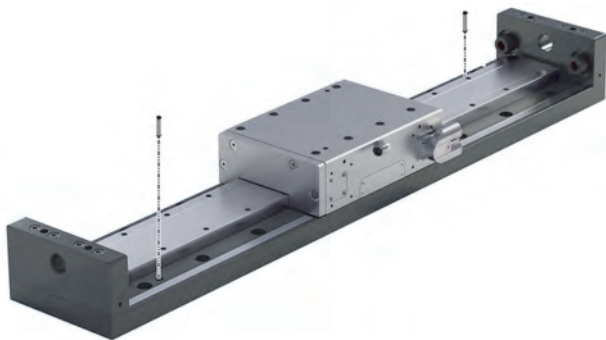

Use screws with the property class specified to mount the product. When determining the length of the screws, take into account the loads and forces acting in your application as well as the characteristics of the supporting structure to which the product is mounted.

1. Place the product at the mounting site in compliance with the transportation instructions and align it according to the holes and the pin holes.
2. Center the product with the two parallel pins and then drive in the first parallel pin by one third.
3. Screw the screws into the holes of the base plate.
4. Slightly tighten the screws.
5. Drive the two parallel pins into the pin holes (positive fit, the parallel pin must be in contact with the base plate and the mounting surface).
6. Tighten the screws with the specified tightening torque.

8.5 Connecting the lubrication hose (for optional automatic lubrication)

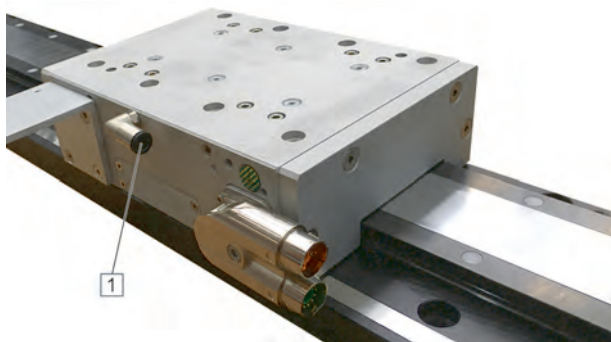

- ✓ Ensure that the lubrication hose is completely bled prior to mounting.
 - ✓ Make sure that the length of a replacement lubrication hose does not exceed 2 m.
1. Connect the lubrication hose to connection [1].

8.6 Inverting the direction of the reference movement



⚠ WARNING

INCORRECT ADJUSTMENT OF THE ENCODER

Modifications to the parameterization of the encoder result in a modification to the zero point.

Failure to follow these instructions can result in death, serious injury, and equipment damage.

- Do not make any modifications whatsoever to the encoder without the approval of WEISS GmbH.

Products with an incremental encoder are equipped with a reference switch. The reference switch is connected to the servo drive.

The direction of movement of the reference movement can be inverted. For this purpose, the reference switch must be mounted at the other side of the linear motor axis.

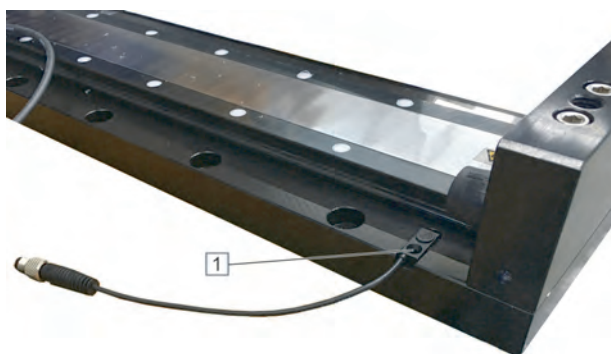

1. Dismount the reference switch [1] and screw it to the opposing side.
2. Modify the direction of counting of the encoder in the software.

8.7 Mounting additional components



⚠ WARNING

IMPROPERLY FASTENED PARTS

Failure to follow these instructions can result in death, serious injury, and equipment damage.

- Verify that the supporting structure and/or the frame and/or the mounting surface for fastening the product are sufficiently rated to withstand all static and dynamic loads and forces during operation.
- Verify that the fastening parts comply with the specifications indicated and that they are sufficiently rated for all load conditions during operation.



⚠ CAUTION

INCORRECT MOUNTING OF ADDITIONAL COMPONENTS

Failure to follow these instructions can result in injury or equipment damage.

- Only mount components to the carriage/primary that are approved by the manufacturer.
- Only use existing holes in the drive carriage/primary for mounting additional components to the drive carriage/primary.
- Do not drill holes into the drive carriage/primary.

8.8 Mounting safety equipment

The product is a partly complete machine pursuant to Directive 2006/42/EU and intended to be incorporated into or assembled with other machinery. The requirements concerning functional safety and the corresponding safety equipment result from the risk analysis and the risk assessment for the final machine or plant.

Selection, mounting, installation, commissioning, operation and maintenance of the safety equipment must be performed by the system integrator (the person who incorporates the product in a machine pursuant to Directive 2006/42/EU, i.e., for example, the machine builder) and/or the operator.

The product requires at least the following safety equipment:

- Emergency Stop system as per IEC 60204-1 / ISO 13850
- Lockable main switch to interrupt the complete power supply to all electrical components of the product

9 Electrical connection



⚠ DANGER

ELECTRIC SHOCK CAUSED BY LIVE PARTS

Failure to follow these instructions will result in death or serious injury.

- Disconnect the mains supply voltage before performing the work and ensure that it cannot be switched on.
- Verify that no hazards can be caused by electrically conductive objects.
- Verify that all cables for the power supply are disconnected from power.
- Verify that all electrical connections are made to the specifications in the wiring diagrams.



⚠ DANGER

ELECTRIC SHOCK DUE TO MISSING COVERS

Failure to follow these instructions will result in death or serious injury.

- Verify that all removed covers are re-installed, and all terminal boxes are closed after you have performed work.



⚠ WARNING

UNANTICIPATED MOVEMENT

Interchanging the motor connections inverts the direction of rotation of the motor.

Failure to follow these instructions can result in death, serious injury, and equipment damage.

- Verify correct wiring and connection of all electrical connections.



⚠ CAUTION

IMPROPERLY INSTALLED CABLES

Failure to follow these instructions can result in injury or equipment damage.

- Verify that the cables are correctly routed.
- Verify compliance with the bend radius specifications for the electrical lines.
- Only use cables with the correct cross sections.
- Verify that the electrical cables are correctly connected to the terminals.

The product is factory-wired. The electrical installation is limited to connecting the cables between the product and the drives.

Electrical installation of any other equipment is the responsibility of the system integrator and/operator.

The electrical cables are pre-assembled with a connector at one cable end.

9.1 Connecting the protective ground conductor



⚠ DANGER

ELECTRIC SHOCK DUE TO INSUFFICIENT GROUNDING

Failure to follow these instructions will result in death or serious injury.

- Verify compliance with all local and national electrical code requirements as well as all other applicable directives, regulations, and standards with regard to grounding of the entire machine.
- Ground all components of the machine before applying voltage.
- Do not use cable conduits as protective ground conductors; instead, use a protective ground conductor inside the cable conduits.
- Verify that the cross section of the protective ground conductor complies with the applicable standards.
- Do not use cable shields as protective ground conductors.

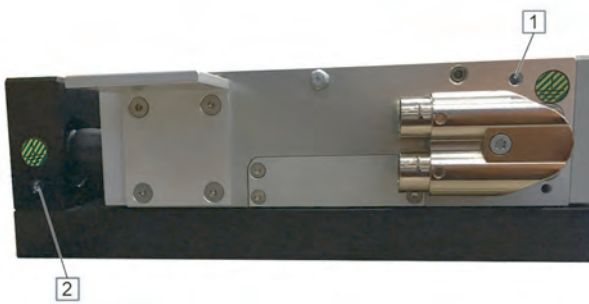

The customer must connect the grounding of the product.

1. Connect a protective ground conductor to the primary/drive carriage [1].
2. Connect a further protective ground conductor to the limit stop [2].

9.2 Connection assignment

Encoder connection "incremental"

<- to servo drive

Pin assignment

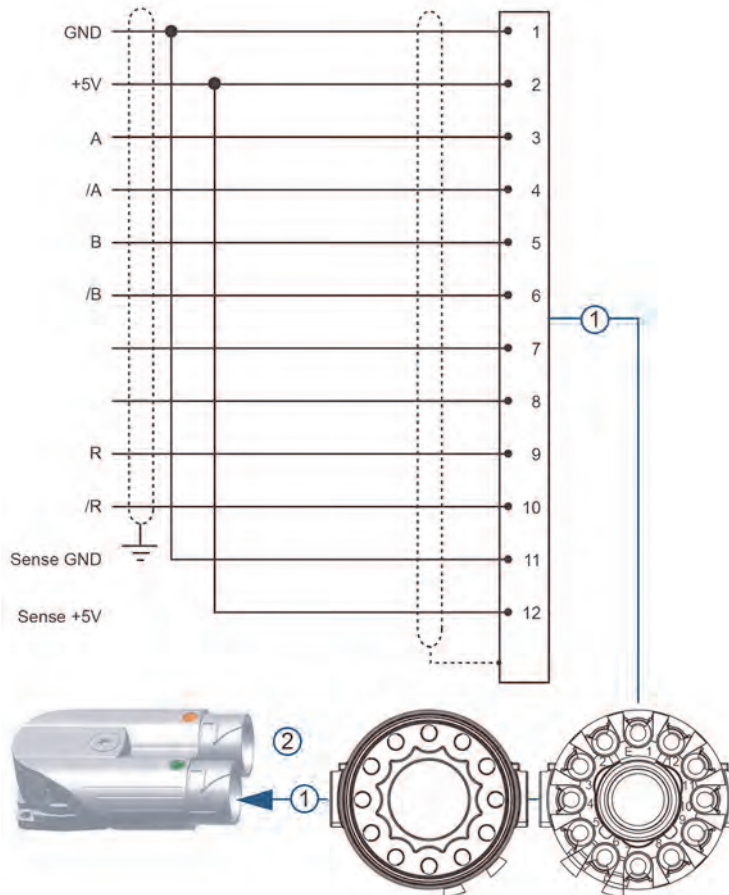

Figure 9: Servo drive an pin assignment

InterContec yTec - 12-pin (EEDA101MR04000001000)

Encoder connection "absolute"

<- to servo drive

Pin assignment

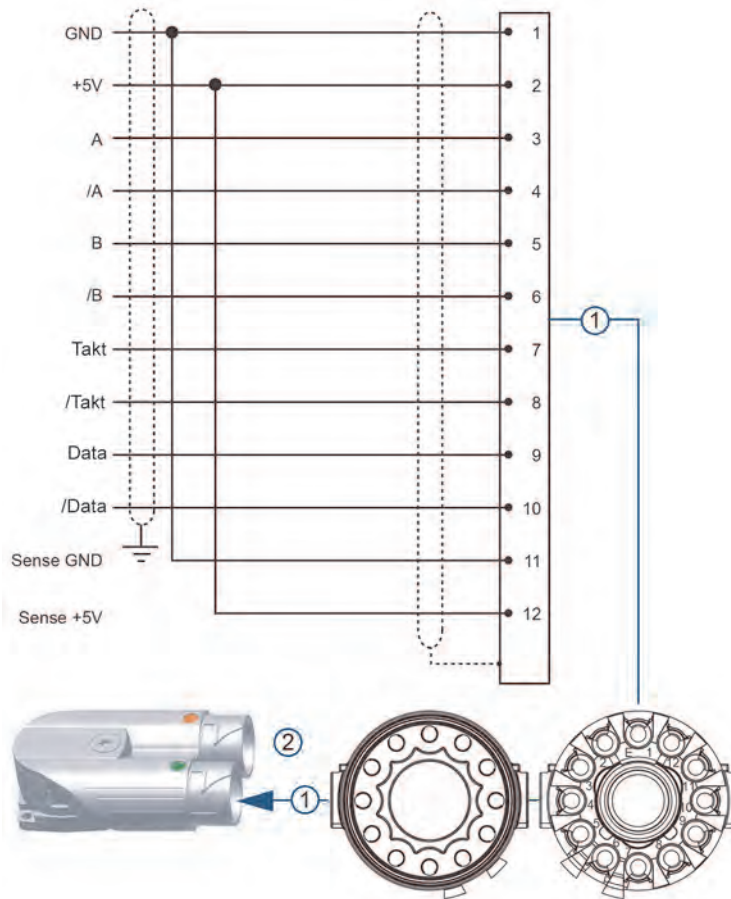

Figure 10: Servo drive an pin assignment

InterContec yTec - 12-pin (EEDA101MR04000001000)

Connection motor

<- to servo drive

Pin assignment

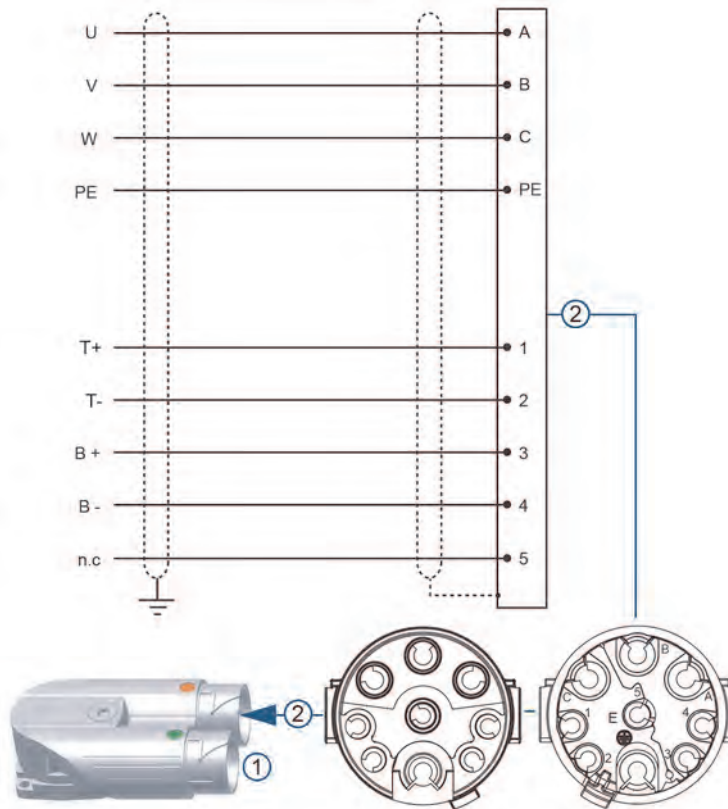

Figure 11: Servo drive an pin assignment

InterContec yTec - 9-pin (EEDA101MR04000001000)

Extension cable encoder



Pos.	Name	Comment
1	Encoder cable	5x2x0,25 + 2x0,5 Ø 8,8mm bending radius moved 10x Ø fixed 6x Ø 5 million bending cycles at a=50m/s ²
2	yTec-plug	ESTB002FR02100001000
3	yTec-plug	EKUB001NN00130001800

yTec-female	Pin	Name	Function	Color	Pin	yTec-male
	1	GND	GND	blue	1	
	2	5V	Encoder +5V	red	2	
	3	A+	Channel A	white	3	
	4	A-	Channel A inverted	brown	4	
	5	B	Channel B	green	5	
	6	B-	Channel B inverted	yellow	6	
	7	CLOCK+	Clock output	grey	7	
	8	CLOCK-	Clock output inverted	pink	8	
	9	DATA+	Data	black	9	
	10	DATEN-	Data inverted	violet	10	
	11	Sense GND	Sense GND	grey/pink	11	
	12	Sense 5V	Sense 5V	red/blue	12	

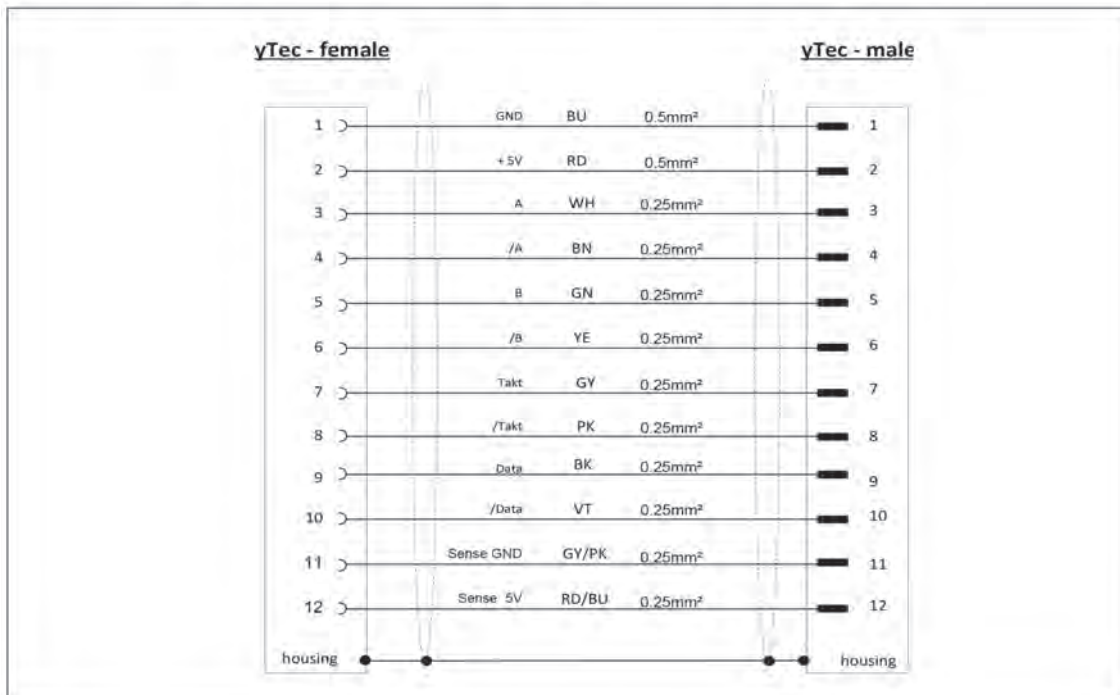

Figure 12: Encoder - yTec

Extension cable motor



Pos.	Name	Comment
1	Motor cable	4 G1,0 +2x(2x0,75) Ø 11,5mm bending radius moved 7,5x Ø fixed 4x Ø 5 million bending cycles at a=50m/s²
2	yTec- plug	ESTB202FR01130500000
3	YTec- plug	EKUB201NN00130500800

yTec-female	Pin	Name	Function	Pin	yTec-male
	A	U	Motor connection U	A	
	B	V	Motor connection V	B	
	C	W	Motor connection W	C	
	PE	PE	Ground	PE	
	1	T+	Temperature sensor	1	
	2	T-	Temperature sensor	2	
	3	B+	Brake	3	
	4	B-	Brake	4	

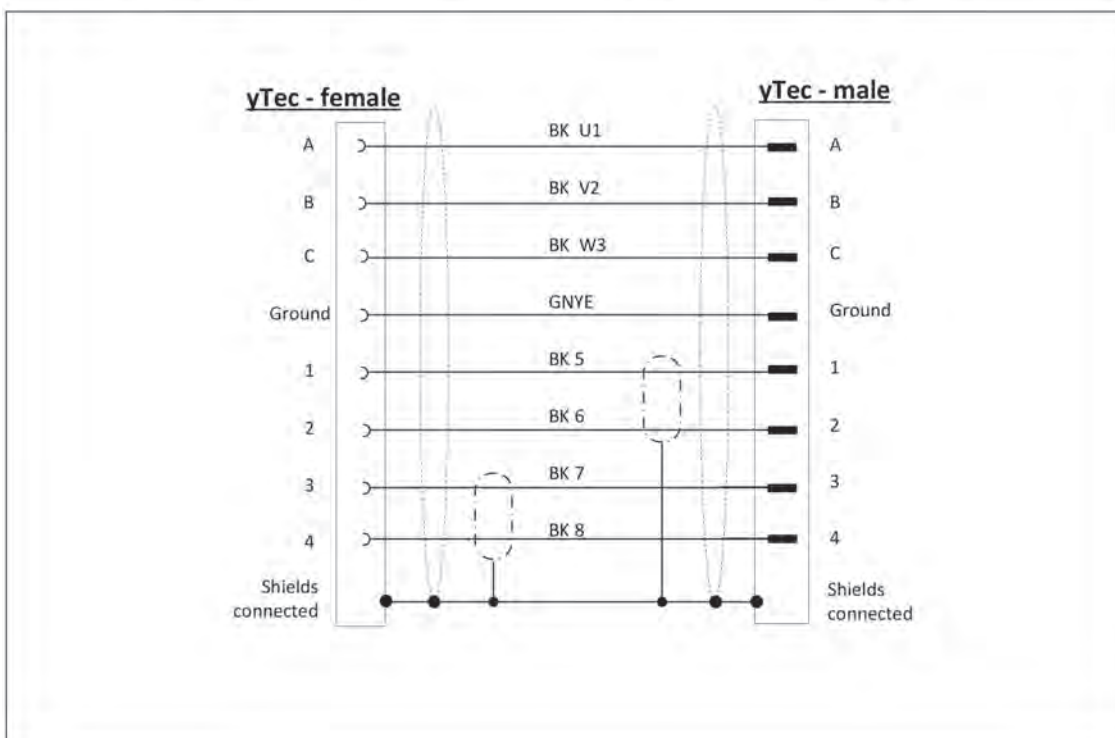
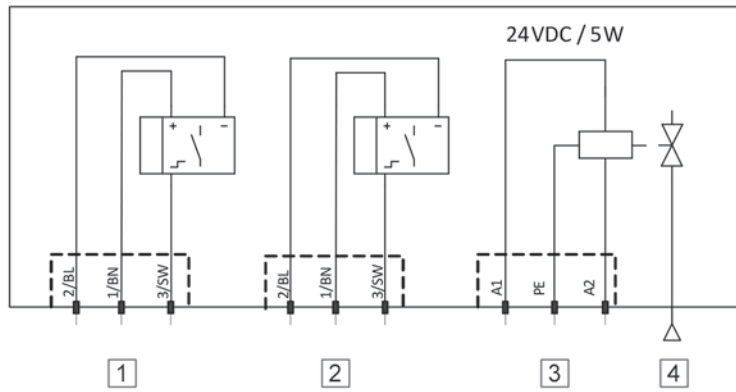

Figure 13: Motor - yTec

9.3 Connection assignment "Automatic lubrication pump" (optional)



- | | |
|--|--|
| <p>1 Level sensor
M8 - 3-pin</p> <p>2 Sensor function
M8 - 3-pin</p> | <p>3 Valve connector, type B</p> <p>4 Connection</p> |
|--|--|



Operation of the automatic lubrication pump without WEISS GmbH controller

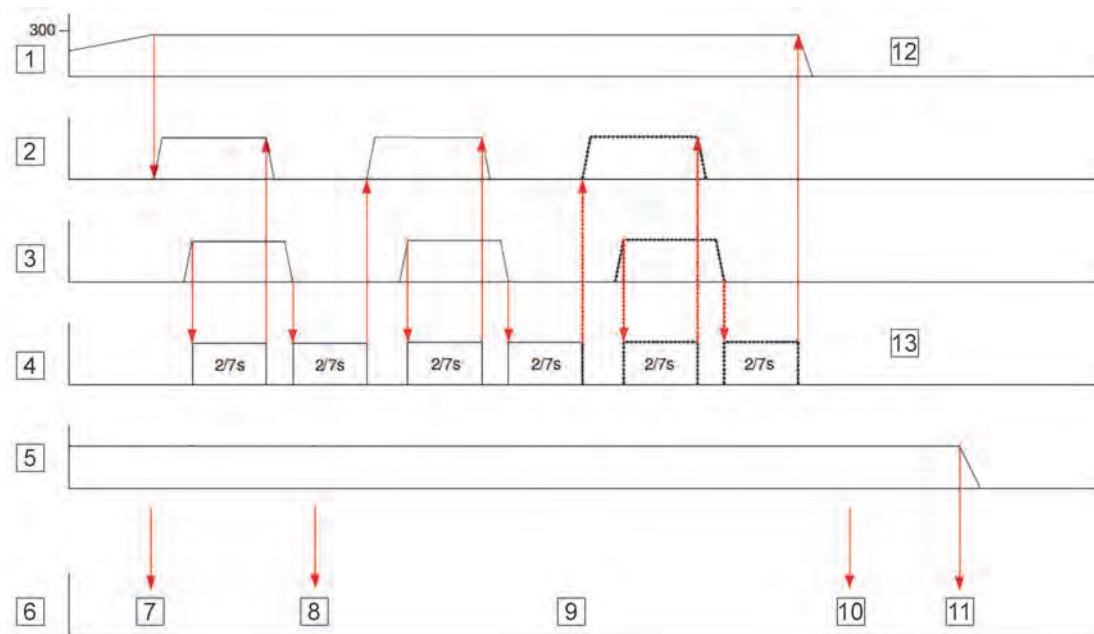

- 1 Kilometrage [km]
- 2 SPS-OUT
Valve coil
- 3 SPS-IN
Lubrication active
- 4 Waiting time
- 5 SPS-IN
Level
- 6 Software
- 7 Check:
- Level OK
- Input lubrication "Active LOW"
- 8 Check:
- Input lubrication "Active LOW"
- 9 If the input lubrication does not turn "Active LOW",
the error message "Error pneumatic supply" is
generated
- 10 Check:
- Level OK
- 11 Error message "Level"
(If the error message is generated during the
cycles of a running lubrication procedure,
the remaining cycles are completed and the
lubrication procedure is terminated)
- 12 Lubrication interval: see table
- 13 Number of cycles: see table

Product type	Lubricant volume (cm ³)	Lubrication interval (km)	Cycles of the automatic lubrication pump	Additional time with 1 m hose (seconds)	Additional time with 2 m hose (seconds)
HN0050A	0.6	300	1	2	7
HN0100A	2.0	300	3	2	7
HN0200A	4.0	300	6	2	7
HN0400A	6.0	300	9	2	7

10 Controller

10.1 Basic information on control



▲ WARNING

LOSS OF CONTROL

Failure to follow these instructions can result in death, serious injury, and equipment damage.

- Consider all potential failure modes of all control paths in your control concept.
- Implement means and measures for all critical functions to achieve a safe state if a control path fails (for example, emergency stop, overtravel of positions, power outage, and restart).
- Implement separate or redundant control paths for all critical functions.
- If the control system of the machine comprises communication links, consider the consequences of unanticipated transmission delays or failures of the link and implement appropriate measures.
- Subject each machine in which the product described in these mounting instructions is used to a comprehensive and thorough commissioning test before operating the machine.

10.2 WEISS GmbH controller/software package (optional)

WEISS GmbH offers a controller/software package for controlling the product.

If this option is used, you must follow all instructions in the corresponding documentations. The documentations can be found on the CD shipped with the product in the controller/software package.

11 Commissioning

11.1 Prerequisites for commissioning

The following requirements must be met before the product may be commissioned:

- The product is properly mounted.
- The electrical equipment for the power supply of the electrical components of the product is correctly installed.
- All cables including the protective ground conductors are properly routed and connected.
- All electrical connections have been made properly.
- The static discharge must be performed properly.
 - The discharge resistance must have been measured and have a value of less than 10 Ohm.
- All parts of the system are properly grounded in compliance with directives, regulations, and standards.
- All safety equipment and EMERGENCY-STOP circuits are operational.
- All environmental conditions are respected.
- All protective covers are properly mounted.
- All tools, equipment, and other objects have been removed from the zone of operation of the product.
- All hazards are excluded.

Prior to commissioning, perform a test for each prerequisite mentioned and verify compliance with all information and specifications contained in these mounting instructions, in all applicable documents, and in all applicable directives, regulations, and standards.

11.2 Performing commissioning



WARNING

UNANTICIPATED MOVEMENT

Incorrect connections or external influences on electrical equipment can cause unanticipated movements.

Failure to follow these instructions can result in death, serious injury, and equipment damage.

- Verify correct wiring.
- Verify that there are no persons or obstacles in the danger zone of the product before starting the product.
- Perform initial test movements without loads and without other processing units.
- Verify that all safety equipment and EMERGENCY STOP circuits are activated prior to commissioning.



⚠ WARNING

UNINTENDED EQUIPMENT OPERATION

Incorrect or unsuitable parameter values or settings can cause unintended movements, trigger signals, and compromise functional safety.

Failure to follow these instructions can result in death, serious injury, and equipment damage.

- Verify that parameter values and settings can only be modified by authorized personnel who fully understand each and every effect of such a modification.
- Verify that all parameter values and settings are correct by performing a test run.



⚠ WARNING

ELECTROMAGNETIC FIELDS

Failure to follow these instructions can result in death, serious injury, and equipment damage.



- Verify compliance with all international, national, and local directives, standards, and safety regulations, including all regulations concerning workplace safety and prevention of accidents, with regard to strong magnetic fields.
- Take all necessary measures to ensure that persons with active medical implants (such as heart pacemakers or insulin pumps), metal implants, and magnetically or electrically conductive objects are not exposed to do the magnetic fields generated by the product.
- Do not operate devices in the vicinity of the product which are sensitive to electromagnetic emission.
- Verify that a distance to the product of at least 15 cm is kept.



⚠ WARNING

HOT SURFACES

The temperature of the product can exceed 80 °C during operation.

Failure to follow these instructions can result in death, serious injury, and equipment damage.

- Avoid unprotected contact with hot surfaces.
- Do not allow flammable or heat-sensitive objects in the vicinity of hot surfaces.
- Before performing work on the product, verify that you wait for a sufficient period of time to allow such parts to cool down to a temperature that allows for safe contact.

Power on the power supply to the product via the main switch.

Check the following points during commissioning:

- Operating state, potential error conditions, and protective equipment
 - During commissioning, perform tests for all operating states and error conditions. In doing so, verify that all protective equipment operates as planned and required.
- Correct operation of the linear motor axis

Commissioning

- There are no overloads.
- There are no unusual jerks. Immediately stop the product in the case of overloads or unusual jerks and verify correct mounting.
- Noise emission
 - Excessive noise emission can be an indication of incorrect mounting, for example, an uneven ground that causes mechanical stress. Immediately stop the product in the case of high noise emission and verify correct mounting and correct setting of the controller parameters.

If the product and/or the machine into which the product is incorporated is temporarily decommissioned, it must be recommissioned. For recommissioning, the same prerequisites must be met as for initial commissioning.

Perform the same tests for each recommissioning of the product as for initial commissioning.

12 Operation

12.1 Basic information on operation



⚠ WARNING

UNINTENDED EQUIPMENT OPERATION

Incorrect or unsuitable parameter values or settings can cause unintended movements, trigger signals, and compromise functional safety.

Failure to follow these instructions can result in death, serious injury, and equipment damage.

- Verify that parameter values and settings can only be modified by authorized personnel who fully understand each and every effect of such a modification.
- Verify that all parameter values and settings are correct by performing a test run.



⚠ WARNING

ELECTROMAGNETIC FIELDS

Failure to follow these instructions can result in death, serious injury, and equipment damage.



- Verify compliance with all international, national, and local directives, standards, and safety regulations, including all regulations concerning workplace safety and prevention of accidents, with regard to strong magnetic fields.
- Take all necessary measures to ensure that persons with active medical implants (such as heart pacemakers or insulin pumps), metal implants, and magnetically or electrically conductive objects are not exposed to do the magnetic fields generated by the product.
- Do not operate devices in the vicinity of the product which are sensitive to electromagnetic emission.
- Verify that a distance to the product of at least 15 cm is kept.

The product is a partly complete machine pursuant to Directive 2006/42/EU and intended to be incorporated into or assembled with other machinery. The information required for operation results from the functionality of the machine or system into which the product is incorporated and from the application implemented with it.

The instructions for the safe operation of the final machine or system must be provided by the system integrator (the person who incorporates the product in a machine pursuant to Directive 2006/42/EU) and/or the operator in the form of a manual with operating instructions, [see chapter 2.3](#).

These operating instructions must be a complete manual which describes all work on and with the product and which contains all information relevant to the product. The system integrator and/or operator must ensure compliance of the operating instructions with all applicable directives, regulations, and standards.

13 Troubleshooting

13.1 Issue, cause and remedy



⚠ DANGER

ELECTRIC SHOCK CAUSED BY LIVE PARTS

Failure to follow these instructions will result in death or serious injury.

- Disconnect the mains supply voltage before performing the work and ensure that it cannot be switched on.
- Verify that no hazards can be caused by electrically conductive objects.
- Verify that all cables for the power supply are disconnected from power.



⚠ WARNING

MOVING PARTS

Failure to follow these instructions can result in death, serious injury, and equipment damage.

- Verify that the zone of operation of the moving parts of the product/machine is safeguarded.



⚠ WARNING

ELECTROMAGNETIC FIELDS

Failure to follow these instructions can result in death, serious injury, and equipment damage.



- Verify compliance with all international, national, and local directives, standards, and safety regulations, including all regulations concerning workplace safety and prevention of accidents, with regard to strong magnetic fields.
- Take all necessary measures to ensure that persons with active medical implants (such as heart pacemakers or insulin pumps), metal implants, and magnetically or electrically conductive objects are not exposed to the magnetic fields generated by the product.
- Do not operate devices in the vicinity of the product which are sensitive to electromagnetic emission.
- Verify that a distance to the product of at least 15 cm is kept.



⚠ WARNING

HOT SURFACES

The temperature of the product can exceed 80 °C during operation.

Failure to follow these instructions can result in death, serious injury, and equipment damage.

- Avoid unprotected contact with hot surfaces.
- Do not allow flammable or heat-sensitive objects in the vicinity of hot surfaces.
- Before performing work on the product, verify that you wait for a sufficient period of time to allow such parts to cool down to a temperature that allows for safe contact.

Issue	Cause	Remedy
The drive carriage/primary does not move properly or not at all	Product is subject to mechanical tension	<ul style="list-style-type: none"> ▪ Verify that the mounting site is level und verify correct mounting ▪ Verify the installation
	Guide rails and/or carriages are polluted. Extraneous objects in the air gap between the drive carriage/primary and the base plate	<ul style="list-style-type: none"> ▪ Clean the guide rails and the magnet ways, see chapter 14.1 ▪ Remove extraneous objects and inspect the product for damage

14 Cleaning

14.1 Performing cleaning



⚠ DANGER

ELECTRIC SHOCK CAUSED BY LIVE PARTS

Failure to follow these instructions will result in death or serious injury.

- Disconnect the mains supply voltage before performing the work and ensure that it cannot be switched on.
- Verify that no hazards can be caused by electrically conductive objects.
- Verify that all cables for the power supply are disconnected from power.



⚠ WARNING

ELECTROMAGNETIC FIELDS

Failure to follow these instructions can result in death, serious injury, and equipment damage.



- Verify compliance with all international, national, and local directives, standards, and safety regulations, including all regulations concerning workplace safety and prevention of accidents, with regard to strong magnetic fields.
- Take all necessary measures to ensure that persons with active medical implants (such as heart pacemakers or insulin pumps), metal implants, and magnetically or electrically conductive objects are not exposed to do the magnetic fields generated by the product.
- Do not operate devices in the vicinity of the product which are sensitive to electromagnetic emission.
- Verify that a distance to the product of at least 15 cm is kept.



⚠ WARNING

HOT SURFACES

The temperature of the product can exceed 80 °C during operation.

Failure to follow these instructions can result in death, serious injury, and equipment damage.

- Avoid unprotected contact with hot surfaces.
- Do not allow flammable or heat-sensitive objects in the vicinity of hot surfaces.
- Before performing work on the product, verify that you wait for a sufficient period of time to allow such parts to cool down to a temperature that allows for safe contact.

▲ WARNING
MISSING PROTECTIVE EQUIPMENT

Failure to follow these instructions can result in death, serious injury, and equipment damage.

- Immediately reinstall protective equipment that you may have removed to perform maintenance work after having completed the maintenance work and verify the effectiveness of the protective equipment.

For cleaning of electrical components and additional components, respect the instructions in the documentations of the manufacturer; refer to the applicable documents.

Use the following cleaning agents for cleaning the product:

Component	Cleaning agents
Drive carriage/primary	Neutral, mildly alkaline
Guide rails	
Magnet way	
Base plate	
Scale	Solvent (for example, isopropanol 2)

1. Clean the guide rails, the drive carriage/primary, the scale, the magnet way and the base plate with a dry, lint-free cloth.
2. Remove excess lubricant with a dry, lint-free cloth.
3. Use a wet cloth and a neutral, mildly alkaline cleaning agent to remove heavy pollution from the guide rails, the drive carriage/primary, the scale, the magnet way and the base plate.
4. Dry the cleaned areas.
5. Remove all equipment from the product.
6. Restore the readiness for operation of the product.



15 Maintenance

15.1 Maintenance plan

When	Activity
At least once per year or every 300 km (manual lubrication only)	<ul style="list-style-type: none"> ▪ Lubricate the linear motor axis, see chapter 15.3
At least every six months	<ul style="list-style-type: none"> ▪ Clean all surfaces of the product, see chapter 14.1
	<ul style="list-style-type: none"> ▪ Verify all screw connections of the product for correct tightening torque
	<ul style="list-style-type: none"> ▪ Verify correct connection of all plug connections
	<ul style="list-style-type: none"> ▪ Check all cables for damage ▪ Check the lubrication hose for the automatic lubrication system for damage. The lubrication hose must not contain air
If required	<ul style="list-style-type: none"> ▪ Replace the grease cartridge at the automatic lubrication pump (verify continuous, even consumption of lubricant), see chapter 15.4
	<ul style="list-style-type: none"> ▪ Bleed the lubrication hose, see chapter 15.5

15.2 Lubricant

NOTICE

INSUFFICIENT LUBRICATION

Failure to follow these instructions can result in equipment damage.

- Respect the lubrication intervals specified in these mounting instructions.
- Only use the lubricants specified in these mounting instructions for lubrication of the product.
- If you want to use a lubricant without FDA approval for relubrication, the factory-applied lubricant must first be completely removed because the two lubricants are not compatible.

Initial factory-lubrication and relubrication with special grease LE-Spezialfett Synt EP2 with the following characteristics:

- Level of purity as per FDA regulations 21 CFR 178.3570
- Approval of NSF H1 (National Sanitary Foundation)

Thickener	Al complex
Operating temperature range	-45 °C to +160 °C
Permissible short-term temperature peak	+200 °C
Dropping point (DIN ISO 2176)	> 250 °C
Cone penetration (DIN ISO 2137)	265 - 295
Type of base oil	Synthetic
Viscosity of base oil at 40 °C (DIN 51562)	350 mm ² /s
Water resistance (DIN 51807 T1)	0 - 90
SKF Emscor test (DIN 51802)	Degree of corrosion 0/0
Designation (DIN 51502)	KPFHC 2 P-40

It is possible to use an equivalent grease.

Use of a lubricant without FDA approval:

- DIN 51502: KP2K-30
- ISO 6743-9: ISO-L-X-CCEB 2

15.3 Lubricating the product (manual lubrication)

The product must be lubricated after 600 km of operation, or at least once per year.

The kilometrage can be read out via the W.A.S. 2 software. In addition, it is possible to read out and reset the value via various parameters (as described in the manual for the W.A.S. 2 software).

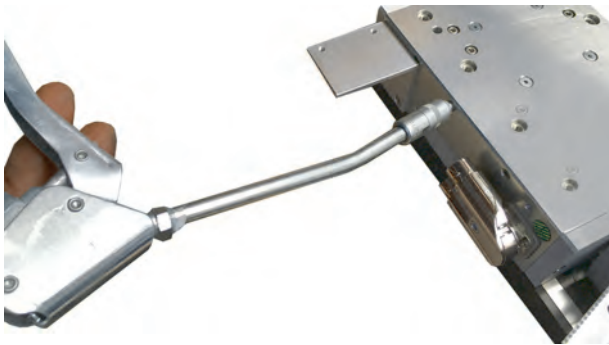

1. Use a grease gun to apply the specified amount of grease via the lubrication nipple.
 - Manually move the drive carriage along the entire stroke several times during the lubrication procedure.
 - If a WEISS manual grease gun is used, one pump stroke corresponds to approx. 0.8 cm³.

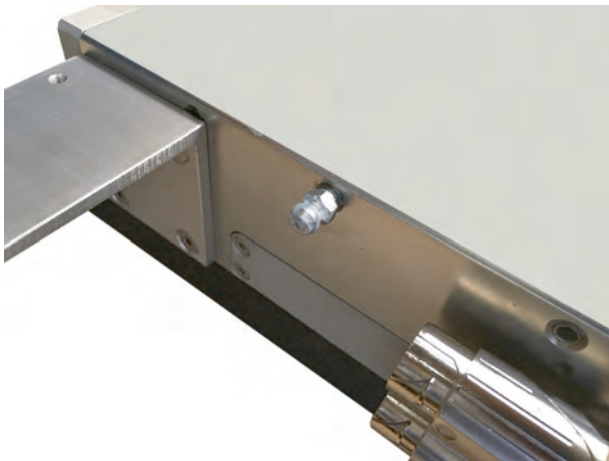

2. Remove excess grease with a soft, lint-free cloth.

Product type	Lubricant volume
HN0050A	1.2 cm ³
HN0100A	4 cm ³
HN0200A	8 cm ³
HN0400A	12 cm ³

Table 1: Lubricant volume

15.4 Replacing the grease cartridge at the automatic lubrication pump

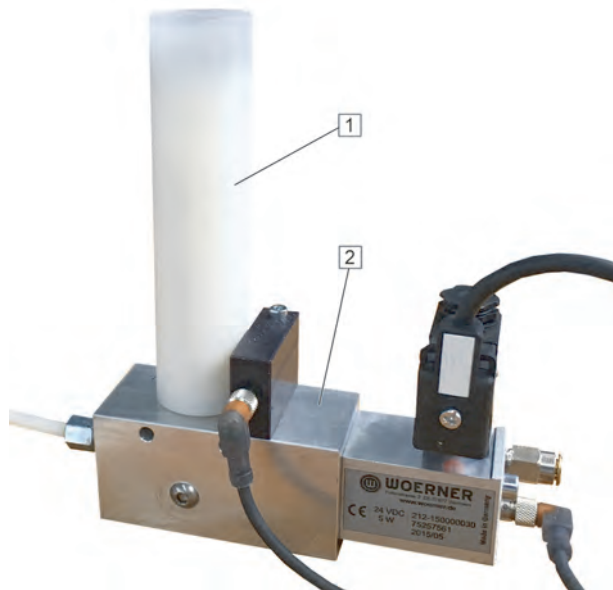

1. Unscrew the grease cartridge [1] from the pump housing [2].



2. Remove the cap from the new grease cartridge.
 3. Press from the bottom until grease escapes from the grease cartridge.
- ✓ This helps to keep air from getting into the lubrication hose.



4. Verify that the seal [3] and the magnets [4] are in the new grease cartridge.
5. Screw the grease cartridge into the pump housing.
6. Bleed the lubrication hose at the automatic lubrication pump, [see chapter 15.5](#).



15.5 Bleeding the lubrication hose

The automatic lubrication pump is delivered with the lubrication hose bled.



The automatic lubrication pump can be operated manually via a rotary switch [1] at the pneumatic valve. For this, compressed air must be supplied.

1. Turn the rotary switch [1] from position "0" to position "1" and back to position "0".
✓ A single pump stroke is performed.

16 Decommissioning

16.1 Decommissioning the product

1. Switch off the product and secure it against unintended switching on.
2. Remove all workpieces and all other objects not belonging to the product from the product.
3. In the case of recommissioning, follow the instructions described, [see chapter 11](#).

17 Dismounting

17.1 Dismounting the product



⚠ WARNING

ELECTROMAGNETIC FIELDS

Failure to follow these instructions can result in death, serious injury, and equipment damage.

- Verify compliance with all international, national, and local directives, standards, and safety regulations, including all regulations concerning workplace safety and prevention of accidents, with regard to strong magnetic fields.
- Take all necessary measures to ensure that persons with active medical implants (such as heart pacemakers or insulin pumps), metal implants, and magnetically or electrically conductive objects are not exposed to do the magnetic fields generated by the product.
- Do not operate devices in the vicinity of the product which are sensitive to electromagnetic emission.
- Verify that a distance to the product of at least 15 cm is kept.

1. Switch off the supply voltage.
2. Dismount the product (reverse sequence of steps), [see chapter 8](#).

18 Disposal

18.1 Disposing of the product

Dispose of the product in compliance with all applicable directives, standards, and safety regulations.

Environmental protection

Dispose of lubricants, greases, residue of cleaning agents and other non-recyclable materials according to the applicable directives, standards, and safety regulations.

19 Service and spare parts

19.1 Worldwide service

If you need the assistance of our service departments, please provide the following information:

- Serial number of the product (see nameplate)
- Description of the problem
- Time of occurrence and circumstances of the problem
- Suspected cause

GERMANY

WEISS GmbH
Siemensstraße 17
74722 Buchen/Odenw.
Phone +49-6281-5208-5999
Fax +49-6281-5208-99
E-mail info@weiss-gmbh.de

SWITZERLAND

WEISS Schweiz GmbH
Friedhofstraße 7
2540 Grenchen
Phone +41-32-6536010
Fax +41-32-6536011
E-Mail info@weiss-gmbh.ch

NETHERLANDS

WEISS Nederland
Kruisstraat 4
7573 GJ Oldenzaal
Phone +31-541-853524
E-mail info@weiss-gmbh.nl

POLAND

WEISS Poland Sp. z o. o.
ul. Wielicka 250
30-663 Kraków
Phone +48-12-281-23-62
Fax +48-12-281-23-63
E-Mail info@weiss-poland.com

ITALY

WEISS Italia S.r.l.
Via dell'Arcoveggio 49/5
40129 Bologna
Phone +39-51-0474967
E-mail info@weiss-italia.it

USA | CANADA

WEISS North America, Inc.
3860 Ben Hur Avenue, Suite 3
Willoughby, OH 44094
Phone +1-888 WEISSNA (888-934-7762)
Fax +1-440-269-8036
E-mail info@weissna.com

SPAIN

WEISS España
Tecnología en máquinas especiales, S.L.
Avda. Juan Carlos I, N°13, 3ªA „Torre Garena“
28806 Alcalá de Henares (Madrid)
Phone +34-91-830-06-86
Fax +34-91-830-06-87
E-mail info@weiss-gmbh.es

UNITED KINGDOM

WEISS UK Ltd.
Meridian House
Winsford Ind Estate
Winsford
Cheshire
CW7 3QG
Phone +44-1606-8605-67
E-mail info@weiss.uk.com

INDIA

WEISS Automation Solutions India Pvt. Ltd.
Office No. 101
Navale IT Park
Survey No. 51/2A/2
Nahre, Pune -411041
Phone +91-20-2469-9810
E-mail info@weiss-india.com

BRASIL

WEISS Brasil Ltda
Rod. BR 280 KM 43, n.º 501 - 3.º Pavimento,
Poço Grande, Guaramirim - SC
Caixa Postal n.º 57 - Cep 89270 - 000
Phone +55-47-99914-9681 ou
+55-47-99971-1554
E-mail info@weiss-brasil.com

ASIA

WEISS Asia
Automation and Components Pte Ltd
18 Boon Lay Way
#07-112
TradeHub 21
Singapore 609966
Phone +65-6570-3274
Fax +65-6684-6757
E-mail info@weiss-asia.com

KOREA

WEISS Korea Co., Ltd.
213-ho, 448, Aenggogae-ro, Namdong-gu,
Incheon, Republic of Korea (21697)
Phone +82-32-228-5208
Fax +82-32-228-5209
E-mail sales@weiss-korea.com

CHINA

WEISS AUTOMATION TECHNOLOGY
(SHANGHAI) CO., LTD.
中国区总部/ Head Office in China
上海/ Shanghai
地址: 上海市嘉定区马陆镇思诚路
1250号8号楼
ADD: Building 8, No.1250 Sicheng Rd., Jiading
District
Phone +86-21-6076-7688 (总机 / Call Center)
Fax +86-21-6076-7699
E-mail info@weiss-china.com

19.2 Ordering spare parts



⚠ WARNING

UNSUITABLE SPARE PARTS AND ACCESSORIES

Failure to follow these instructions can result in death, serious injury, and equipment damage.

- Only use spare parts and accessories which are approved by the manufacturer.

Please provide the following information when ordering spare parts:

- Serial number of the product (see nameplate)
- Part number of the spare part according to spare parts list
- Quantity of spare parts required

19.3 Spare parts

Part number	Designation	Description	Qty
LUBEMAN-0800-0000-00	Manual grease gun	-	1
LUBEMAN-0810-0000-00	Spare cartridge	-	1
LUBESYS-0800-0000-00	Automatic lubrication pump	-	1
LUBESYS-0810-0000-00	Spare cartridge	Diameter hose 6 mm	1
LUBESYS-0810-0001-00	Spare cartridge	Diameter hose 4 mm	1



**INSPIRING PEOPLE
GREAT SOLUTIONS**

WEISS GmbH

Siemensstraße 17 74722 Buchen
Telefon 06281 5208-0 Telefax 06281 5208-99
info@weiss-international.com
www.weiss-international.com